

Radial Arm Drill Press

Model 1230

Operating instructions and parts manual

Part No. 9078241
Revision A



Table of Contents

Cover Page	1
General Specifications	4
Operating Precautions	5
Operating Instructions	7
Lubrication and Coolant	13
Machine Set-up	14
Wiring Diagram.....	16
Replacement Parts.....	17

General specifications

The Wilton Model 1230 is a powerful and versatile radial arm drill press. The drill head is mounted on an arm and can move along the arm to position the spindle over the work piece. The arm, itself, can be rotated on its support column to allow centering the spindle over the work piece.

Drilling can be performed manually or with power assistance. In addition, parameters of RPM, power feed rate and drilling depth can be pre-set by the operator, using controls conveniently positioned on the drill head, to allow any hole to be drilled using power feed.

A precision machined box table is delivered with the Model 1230 to allow convenient positioning and clamping of smaller work pieces. The box table may be removed from the base to allow larger workpieces to be positioned and clamped on the precision machined base, itself.



Machining capacities

	Drilling	Tapping	Boring
Steel	2 1/8 in. (53mm)	1 1/8 in. (28mm)	3 3/8 in. (84mm)
Cast iron	2 1/2 in. (63mm)	1 3/4 in. (44mm)	4 3/4 in. (119mm)

Overall dimensions and specifications

Column diameter	11 13/16 in. (295mm)
Column to spindle center distance, max.	46 in. (1150mm)
Column to spindle center distance, min.	13 3/8 in. (334mm)
Spindle travel along arm, total	35 in. (875mm)
Base surface to spindle end, max. (no tooling)	54 in. (1350.0mm)
Base surface to spindle end, min. (no tooling)	19 3/8 in. (484mm)
Quill (spindle) travel	9 7/8 in. (247mm)
Arm movement range on support column	34 5/8 in. (866mm)
Box table dimensions	27 7/8 x 20 1/2 x 16 1/2 in. (697x513x413mm)
Base dimension	67 3/4 x 25 15/16 x 6 1/2 in. (1694x648x163mm)
Spindle taper	Morse #4
Spindle speeds, RPM	45-1550
Feed rates (distance/revolution)	0.002, 0.004, 0.006 in/rev (0.005, 0.010, 0.030 mm/rev)
Main motor HP	5
Arm raising motor HP	1
Clamping motor	1
Coolant pump motor HP	1/8
Machine height (floor to max.)	109 1/2 in. (2,738mm)
Net weight (approx)	4,620 lb. (2,100 kg)



WARNING

- Misuse of this machine can cause serious injury.
- For safety, machine must be set up, used and serviced properly.
- Read, understand and follow instructions in the operator's and parts manual which was shipped with your machine.

When setting up machine:

- Always avoid using machine in damp or poorly lighted work areas.
- Always be sure machine is securely anchored to the floor.
- Always keep machine guards in place.
- Always put start switch in "OFF" position before plugging in machine.

When using machine:

- Never operate with machine guards missing.
- Always wear safety glasses with side shields (See ANSI Z87.1)
- Never wear loose clothing or jewelry.
- Never overreach — you may slip and fall into the machine.
- Never leave machine running while you are away from it.

- Always shut off the machine when not in use.

When servicing machine:

- Always unplug machine from electrical power while servicing.
- Always follow instructions in operators and parts manual when changing accessory tools or parts.
- Never modify the machine without consulting Wilton Corporation.

You — the stationary power tool user — hold the key to safety.

Read and follow these simple rules for best results and full benefits from your machine. Used properly, Wilton's machinery is among the best in design and safety. However, any machine used improperly can be rendered inefficient and unsafe. It is absolutely mandatory that those who use our products be properly trained in how to use them correctly. They should read and understand the Operators and Parts Manual as well as all labels affixed to the machine. Failure in following all of these warnings can cause serious injuries.

Machinery general safety warnings

1. Always wear protective eye wear when operating machinery. Eye wear shall be impact resistant, protective safety glasses with side shields which comply with ANSI Z87.1 specifications. Use of eye wear which does not comply with ANSI Z87.1 specifications could result in severe injury from breakage of eye protection.

2. Wear proper apparel. No loose clothing or jewelry which can get caught in moving parts. Rubber soled footwear is recommended for best footing.

3. Do not overreach. Failure to maintain proper working position can cause you to fall into the machine or cause your clothing to get caught — pulling you into the machine.

4. Keep guards in place and in proper working order. Do not operate the machine with guards removed.

5. Avoid dangerous working environments. Do not use stationary machine tools in wet or damp locations. Keep work areas clean and well lit. Special electrics should be used when working on flammable materials.

6. Avoid accidental starts by being sure the start switch is "OFF" before plugging in the machine.

7. Never leave the machine running while unattended. Machine shall be shut off whenever it is not in operation.

8. Disconnect electrical power before servicing. Whenever changing accessories or general maintenance is done on the machine, electrical power to the machine must be disconnected before work is done.

9. Maintain all machine tools with care. Follow all maintenance instructions for lubricating and the changing of accessories. No attempt shall be made to modify or have makeshift repairs done to the machine. This not only voids the warranty but also renders the machine unsafe.

10. Machinery must be anchored to the floor.

11. Secure work. Use clamps or a vise to hold work, when practical. It is safer than using your hands and it frees both hands to operate the machine.

12. Never brush away chips while the machine is in operation.

13. Keep work area clean. Cluttered areas invite accidents.

14. Remove adjusting keys and wrenches before turning machine on.

15. Use the right tool. Don't force a tool or

attachment to do a job it was not designed for.

16. Use only recommended accessories and follow manufacturers instructions pertaining to them.

17. Keep hands in sight and clear of all moving parts and cutting surfaces.

18. All visitors should be kept at a safe distance

from the work area. Make workshop completely safe by using padlocks, master switches, or by removing starter keys.

19. Know the tool you are using — its application, limitations, and potential hazards.

General Electrical Cautions

This machine should be grounded in accordance with the National Electrical Code and local codes and ordinances. This work should be done by a qualified electrician. The machine should be grounded to protect the user from electrical shock.

Wire sizes

Caution: for circuits which are far away from the electrical service box, the wire size must be increased in order to deliver ample voltage to the motor. To minimize power losses and to prevent motor overheating and burnout, the use of wire sizes for branch circuits or electrical extension cords according to the following table is recommended:

Conductor length	AWG (American wire gauge) number	
	240 volt lines	120 volt lines
0-50 feet	No. 14	No. 14
50-100 feet	No. 14	No. 12
Over 100 feet	No. 12	No. 8

Safety instructions on drill presses

1. All work shall be secured using either clamps or a vise to the drill press table. It is unsafe to use your hands to hold any workpiece being drilled.

2. Drill press head and table shall be securely locked to the column before operating the drill press. This must always be checked prior to starting the machine.

3. Always use the correct tooling. Tooling shall always be maintained and properly sharpened. All tooling must be run at the proper speeds and feeds as they apply to the job. Use only recommended accessories and follow those manufacturers instructions pertaining to them. Tooling shall not be forced in to any workpiece but fed according to the proper specifications. Failure to follow these instructions will not only ruin the tooling as well as the machine, but can cause serious injury.

4. Never brush away any chips while the machine is in operation. All clean up should be done when the machine is stopped.

5. Keep hands in sight. Do not put hands or

fingers around, on, or below any rotating cutting tools. Leather safety gloves should be used when handling any sharp objects or cutting tools. See **Figure A**.

6. Always wear protective eye wear when operating, servicing or adjusting machinery. Eyewear shall be impact resistant, protective safety glasses with side shields complying with ANSI Z87.1 specifications. Use of eye wear which does not comply with ANSI Z87.1 specifications could result in severe injury from breakage of eye protection. See **figure B**.

7. When drilling in material which causes dust, a dust mask shall be worn. See **Figure C**.

8. Avoid contact with coolant, especially guarding the eyes.

9. Non-slip footwear and safety shoes are recommended. See **figure D**.

12. Wear ear protectors (plugs or muffs) during extended periods of operation. See **figure E**.

6

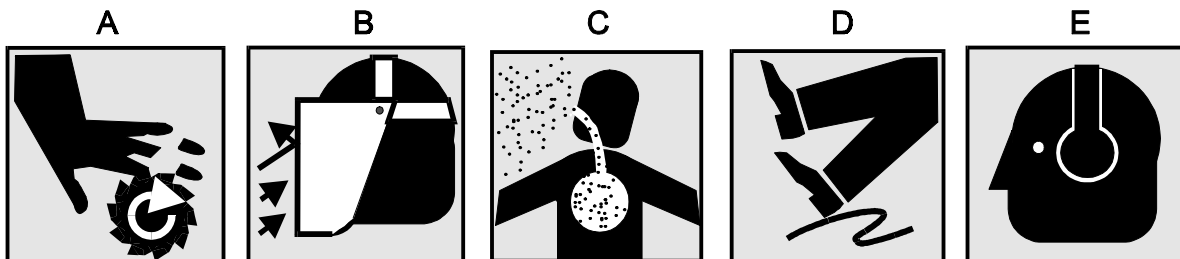

Operating Instructions

Clamping workpieces to the machine

Both the box table and the base surface are slotted to accept a suitably sized T-slot clamp. Before beginning any work on the drill press, anchor the work piece, and the box table, too, if used, to be certain the workpiece and/or box table will not move when the drill, tap or boring tool enters the workpiece.

Caution

Failure to properly anchor the workpiece and box table could result in damage to the machine, damage to the workpiece, and worse -- severe injury and possibly *death* to the machine operator. *Never* work on the drill press without clamping the materials using a T-slot system set-up.

Figure 1: Drill press nomenclature

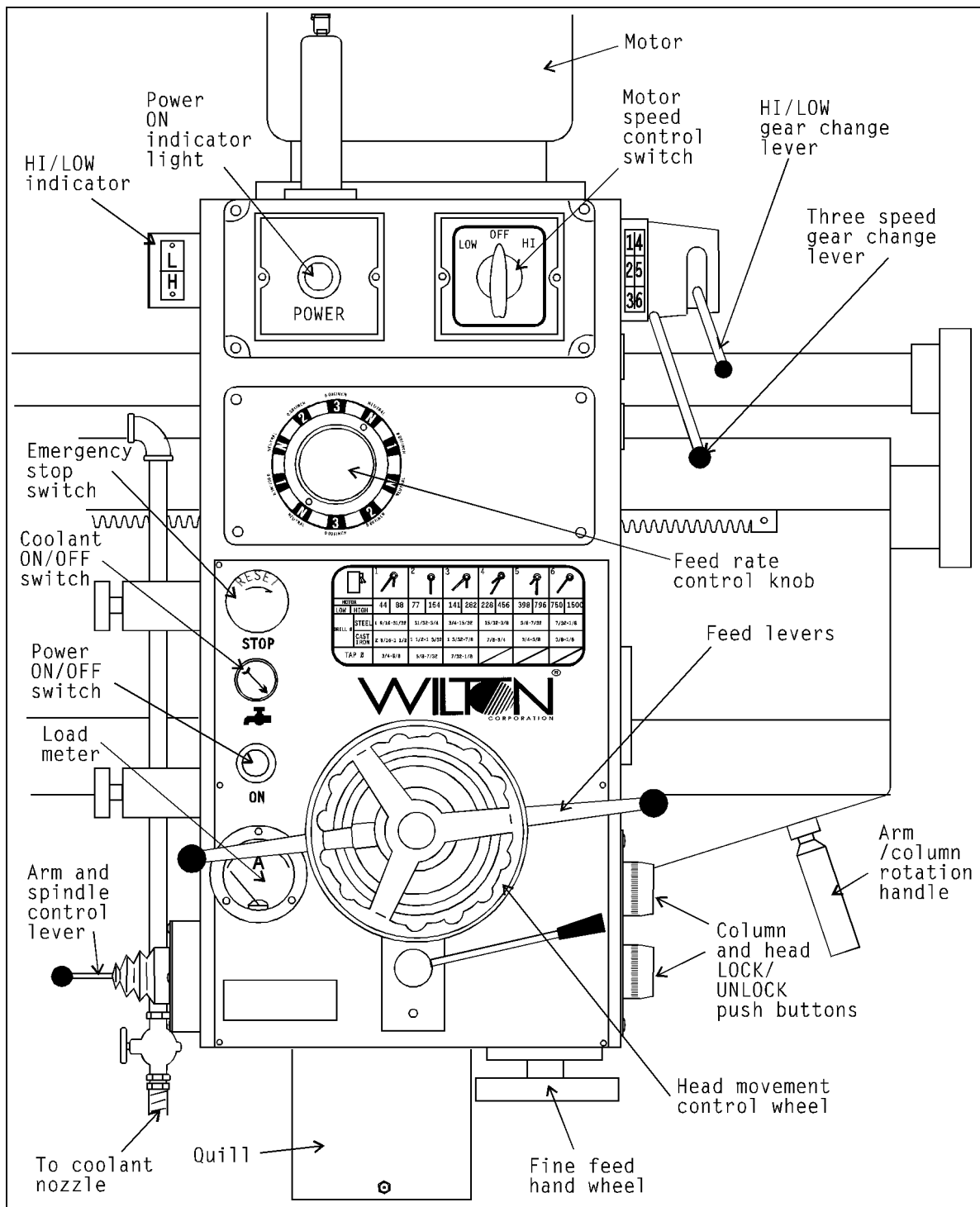

Inserting tooling

The Model 1230 uses a #4 Morse taper in the spindle to secure tooling. Any drill, milling cutter, or tool holder with a #4MT can be inserted into the quill.

Caution

The first step in removing or inserting any tooling is to be absolutely certain the machine cannot be accidentally started during the insertion or removal operation. The only way to be certain of this fact is to disconnect power to the machine using the service box cut-out switch. The service box (typically the one holding the fuses or circuit breakers will have been installed by the electrician who connected the machine to its service branch) should have a cut-out switch or lever on the outside of the box. Put the switch or lever in the OFF position before inserting or removing tooling.

To insert tooling:

1. Observe the caution, above, and be certain all power to the machine has been disconnected.
2. Be certain the spindle is clean, free from oil, and ready to accept the shank of any tooling.
3. Check the shank of the tooling to be certain the tooling is free from dirt, nicks or burrs. If any nicks or burrs are discovered, file and/or stone the shank until the shank is smooth.
4. Be certain the quill is in the full UP position.
5. Slide the shank of the tooling into the spindle until it seats.
6. Use a soft-faced mallet (such as lead, plastic, brass, etc.) to give the tooling a sharp tap on its tip. This will secure the tooling firmly in the taper.
7. Re-establish power to the machine and the drill is ready to use.

To remove tooling:

1. Observe the caution above and be certain all electrical power to the drill press has been cut off.
2. Place a wood block under the tooling in the spindle to prevent it from being damaged, should it fall out of the quill during the removal process.
3. Lower the quill by using the feed levers until the tool removal window is exposed.
4. Using a suitable tapered drift, insert the drift in the removal window, above the tip of the tooling shank.
5. Using leather gloves to prevent cuts from the tooling, hold the tooling with you hand to prevent it from falling from the quill.
6. With your free hand, using a hammer, tap the tapered drift and the tooling will loosen from the taper and can be removed. The spindle is now ready for the insertion of other tooling with a #4 MT.

Positioning the tooling over the workpiece.

After the workpiece has been clamped to the base or table you can position the tooling over the workpiece by doing any or all of the following:

1. Adjusting the height of the arm on the support column.
2. Moving the drill head along the arm.
3. Rotating the column upon which the arm and head are attached.

Unlocking the arm and column mechanisms

A motorized locking system is used to lock the head to the arm, the arm to the column, and the column to the base.

The lock and unlock buttons which control the locks are located on the right-hand side of the drill head. When you push UNLOCK, all of the locks are unlocked. When you push LOCK, all of the locks are locked.

Caution

Always be certain the locks are engaged before using the drill press. Pull on the arm handle and try to rotate the head locating wheel before pushing the spindle ON button. Failure to have all locks locked may result in damage to tooling, damage to the work piece, and possible injury to the operator.

Raising and lowering the radial arm

1. Power to the drill press must be ON -- then release the machine locks by pushing the UNLOCK push button.
2. Use the control lever -- push it upward or downward as required -- (see Fig. 3) to raise or lower the arm to the required height. See also, *Using the control lever.*
3. When the arm is at the required height and if no other adjustments to spindle location are required, push the LOCK push button to re-lock all machine locks.

To move the drill head along the arm

1. Power to the drill press must be ON -- then release the machine locks by pushing the UNLOCK push button.
2. Using the wheel in the center of the drill head, turn the wheel to move the drill head along the arm. (See Fig. 1.)
3. When the drill head is at the desired position on the arm and if no other adjustments to spindle location are required, push the LOCK push button to re-lock all machine locks.

CAUTION

NEVER swing the drill press arm using the support column unless you are absolutely certain the drill press base is firmly attached to the shop floor. You can tell if the base is bolted to the floor by checking the mounting pads at the four corners of the base. There should be a securing bolt through each mounting pad.

If the arm is moved off of its position directly above the base and the base is not bolted to the floor, THE DRILL MAY TIP OVER AND CAUSE SERIOUS INJURY OR DEATH TO THE DRILL PRESS OPERATOR (YOU!!) and will certainly result in serious damage to the drill press, itself. Don't take chances. Always look for bolts at the mounting pads before swinging the drill press arm.

Moving the arm on the support column

1. Power to the drill press must be ON -- then release the machine locks by pushing the UNLOCK push button.
2. Use the handle at the end of the arm (see Fig. 1) to move the column (and, therefore, to swing the arm) as necessary to the required spindle position.
3. When the spindle is positioned correctly and no other adjustments are required, push the LOCK push button to re-lock all machine locks.

Setting spindle speed

Spindle speeds are established using the gear change levers on the upper right-hand side of the drill head. (See Fig. 1.) The shorter of the two levers operates a two-speed mechanism which puts the gearbox in either high gear or low gear. There is a "HI/LOW" readout on the upper left hand side of the drill head which tells you which speed range is selected.

The longer gear change lever operates a three speed gearbox mechanism. The lowest gear and spindle speed is selected by pushing the lever away from you -- that is, by rotating the change shaft counterclockwise. The highest gear and spindle speed is selected by pulling the lever toward you -- rotating the shaft clockwise. There is a detent in the middle of the lever travel to tell you when the lever is in the intermediate gear position.

This gearbox set-up gives you a total of six spindle speeds which may be selected. The two-speed spindle drive motor, therefore, increases the number of available spindle speeds to 12. The specific spindle speed selected clearly depends on the position of *both gear change levers* and whether the *motor switch* on the top front of the drill head is

on LOW or HI speed. There is a chart on the front of the drill head which shows you the spindle speeds available and the gear change lever and motor switch values required to select each speed. See Fig. 1.

On the gear change table you will also find the recommended drill sizes for the various speeds which are selectable. THESE RECOMMENDATIONS ARE ONLY APPROXIMATE. With the wide variety of drill types and coatings available, the variety of cutting fluids which might be used, and the even wider variety of work piece materials which you might be machining -- you need to consult with your tooling, coolant and/or work piece suppliers to determine the best spindle speed to use for any specific drilling operation.

Caution

Do not try to change gears while the spindle is turning. This may cause serious damage to the spindle drive system.

Allow the spindle to come to a complete stop before attempting to change gears. If the gear change lever you want to move does not slip easily into the new position you require, jog the motor for a second using the control lever. Then allow the spindle to come to a stop again before attempting to change gears, again. Repeat this jogging process, as necessary, until the gears match up properly for changing.

Setting feed rate and depth of cut

The Model 1230 has limit switches on the quill which cuts off electric power to the drive motor when the quill has reached either the upper or lower limit of its travel. This system is designed to prevent gearbox damage if the power feed mechanism is engaged -- damage which would occur if the quill were to bottom out against the upper or lower limit of quill travel. In the event of failure of either limit switch there is also a safety clutch mechanism which will slip when the limits of travel are reached.

However, while you are able to use virtually the full travel of the quill for drilling or other operations, the drill press operator typically sets both the rate of feed -- travel-per-revolution of the spindle -- and the depth of cut -- that is, the total distance the quill moves to make the required depth of cut.

These two operations are described, here:

Setting feed rate

The feed rate is set using the knob and dial on the front of the drill head. See Fig. 1. The knob on the dial can be rotated to select any of three different

feed rates, plus a neutral position where the power feed does not operate on the quill.

It is recommended that when doing operations which do not require power feed that the dial be set to the neutral position. This minimizes any wear on the power feed mechanism.

The feed rate selected is indicated by a pair of rivet heads on the edge of the rate setting dial. These values are indicated on the far outer edge of the readout.

Clearly, whenever the indicator rivets are at an "N" position, no feed or "neutral" has been selected.

Any of the three feed rates are available for selection using any of the spindle speeds available. There will be a recommended feed rate for any drilling or boring operation, and this rate must be determined by consulting appropriate machining handbooks or by consulting with your tooling, coolant and work piece suppliers.

Setting depth of cut using the power feed system

There is a mechanism for engaging the power feed and there is also a mechanism (a "trip mechanism") which can be set to disengage the power feed when a pre-set depth has been reached.

The feed levers can be pulled outward -- or

pushed inward -- on pivots which are in the feed lever hub. When the feed levers are pushed toward the drill head, the power feed mechanism is disengaged. When the feed levers are pulled outward, the power feed system is engaged. In the power feed position (outward) the quill and spindle will be driven EITHER until they reach the limit of travel and the limit switches cut off power -- OR until the trip mechanism disengages the power feed, automatically -- OR until the drill press operator pushes the feed levers into the disengaged position.

To set the depth of cut

1. Unlock lever A -- See Fig. 2.
2. Use the feed levers to lower the drill until it touches the work piece.
3. Rotate the dial D until the rivet on the dial -- C -- is at the feed depth required on the scale on graduated dial B.
4. Lock lever A.
5. Pull the feed levers out to engage the power feed clutch.

Note: Because the ring for Dial B makes one rotation before contacting the mechanical trip dog, you are limited to 4 inches (100mm) of travel during any power feed operation. If you need to make deeper holes you will need to do the machining in steps.

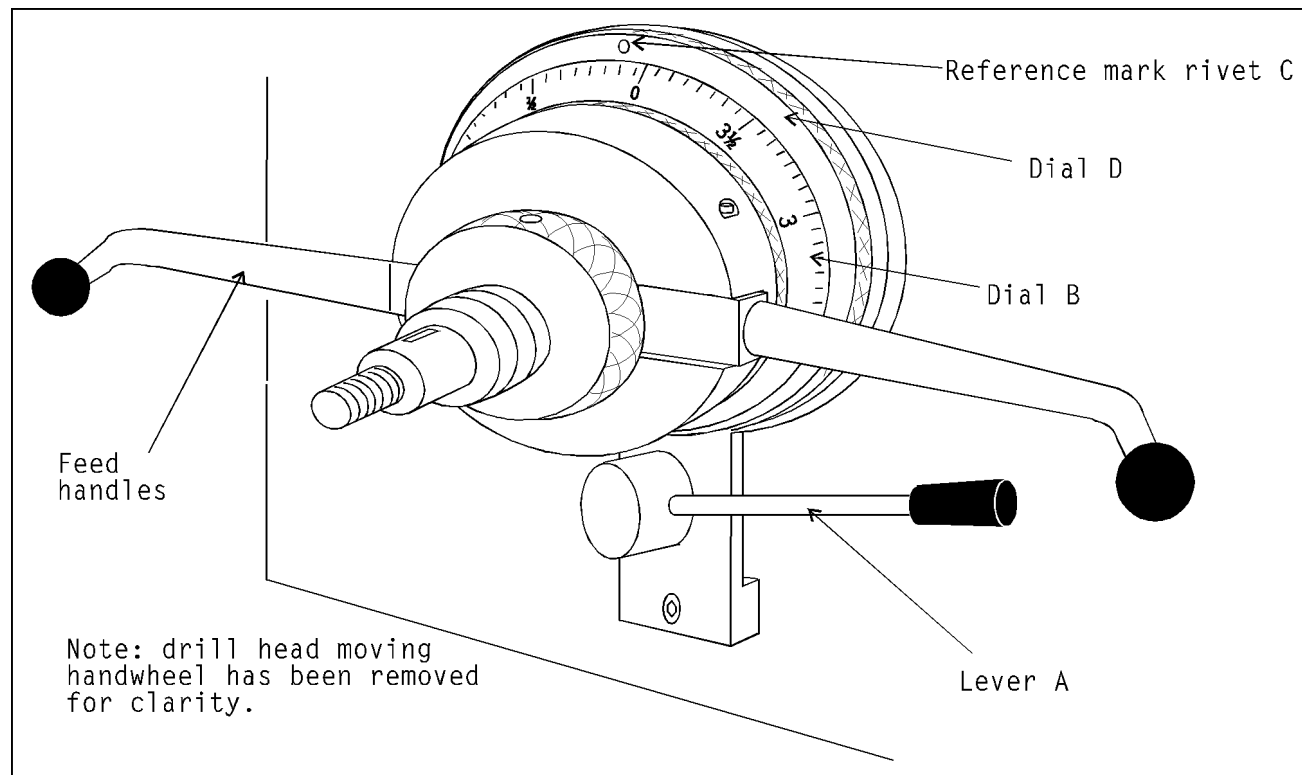

Figure 2: Power feed controls

Spindle direction and power feed

The spindle can be driven clockwise or counterclockwise. The direction of rotation is controlled by the control lever on the left hand side of the drill head. See Fig. 1.

Clockwise or "forward" rotation is the direction of rotation for right-hand tooling -- which is the vast majority of tooling used in machine operations. However, if you use left-hand tooling for any operations, the spindle direction can be set to counterclockwise or "reverse."

The power feed direction is determined by the spindle direction. When the spindle is set to its most common direction -- clockwise or forward -- the quill and spindle are driven downward. When the spindle direction is set to counterclockwise or reverse direction, the quill and spindle are driven upward.

Hand feed -- roughing operations

When the feed levers are pushed toward the drill head the power feed mechanism is disengaged. In this position, the feed levers can be used to move the quill and spindle and perform manual drilling or other machining operations.

Fine hand feed using the power feed system

The fine feed control wheel is located on the underside of the right-hand side of the drill head. See Fig. 1. The fine feed control is used as follows:

1. Set the feed rate dial to N -- neutral.
2. Pull the feed levers out so the power feed clutch is engaged.
3. Turn the drill press POWER switch ON and set the control lever so the spindle is turning in the correct direction for the operation you are performing.
4. Turn the fine feed control wheel by hand. The quill and spindle will move downward or upward (depending upon which way you turn the wheel and the direction the spindle is turning) until you stop turning the control wheel.

Power ON and power OFF

If your Model 1230 was connected to its service branch correctly, there will be a service disconnect with an external power cutoff lever or switch which disconnects the drill press from the service branch. This is your ultimate protection against accidental machine start-up when clamping work pieces to the machine and/or inserting or removing tooling. Always be certain you have turned off power at this disconnect before doing these operations.

Once your workpiece is clamped securely and

the tooling is installed, you can reestablish power to the machine by turning the cut-out panel back ON. This will reestablish power to the machine control system and will allow you to use the motor which raises and lowers the arm to position the tooling over the work piece. Raising and lowering of the arm is controlled by the control stick -- see Fig. 3 and read page 7, *Raising and lowering the radial arm.*

Power ON light

When the cutout box power is ON, the POWER light on the upper left hand side of the drill head (Fig. 1) will be lit. In this mode, power to the coolant pump and to the spindle drive motor is controlled by the switches on the control console.

Flood coolant control

The flood coolant system provided with the drill press is turned on by turning the switch to the ON position. Power OFF to the coolant pump is achieved by turning the switch counterclockwise to its OFF position. (If coolant does not flow, check the pump rotation by observing the pump shaft. It should be rotating in the direction of the arrow on the pump casting. If it is not rotating in the correct direction, see *Electrical*, for more information.)

Spindle motor controls

The power to the spindle motor controlled as follows:

1. The cutout box control lever must be in the ON position so power is being fed to the drill press.
2. The two speed spindle drive motor switch must be in either HI or LOW position.
3. The control ON/OFF switch must be pushed ON.
4. The arm/spindle control lever must be pulled forward (clockwise rotation) or backward (counterclockwise rotation.) See *Using the control lever*, page 11.

Turning spindle drive motor power OFF

To turn power OFF on the spindle drive motor do one of the following:

1. Put the two speed motor switch in OFF position, OR...
2. Push the Control ON/OFF switch off, OR...
3. Put the arm/spindle control lever in its middle (neutral) position, OR...
4. Push the large, red emergency off STOP switch, OR...
5. When servicing the tooling or other machine components, put the service disconnect lever in OFF position.

Once the STOP switch has been pushed (4., above) none of the other switches on the panel can be used to control power to the spindle drive motor or coolant pump until the STOP switch has been re-set.

Resetting the STOP switch

1. Turn the switch in the direction of the arrow on the red button -- clockwise. The switch is reset and the other spindle motor controls can be used.

Using the load ammeter

An ammeter on the control console is used to monitor the load on the spindle drive motor. It is connected into one of the three power lines which supply the main drive motor.

When the drive motor is ON and up to speed, and there is no tooling being used to drill, tap or bore a hole, the ammeter should read approximately 2.5 amps. If it is above this value there is a problem internally (such as lack of lubrication in the gear-boxes, bad bearings, etc.) which means you should turn off the machine and determine the cause of the excessive free-running load.

Monitor the the ammeter during machining operations. The ammeter should stay below 9 amps or current draw during machining. You should adjust your spindle speed, feed rate and coolant use to maintain the full load current draw below the 9 amp value.

If you exceed 9 amps current draw a thermal limiter switch in the electrical control panel will trip. If this occurs, a licensed electrician should be used to locate and re-set the thermal limiter switch.

Tapping operations

When performing tapping operations :

1. Determine the most efficient tapping speed (spindle speed) by consulting appropriate machinist's tables, your tap supplier, coolant supplier and/or work piece supplier.
2. Be certain the power feed dial is in N or neutral position. See *Setting power feed rate*, page 8.
3. Turn the spindle motor ON. Also, turn on the coolant pump if coolant is being used.
4. Move the control lever to FORWARD.
5. Use the feed levers to move the tap into its pilot hole until the tap makes its initial thread cut and is engaged in the workpiece.
6. Allow the tap to "self feed" into the pilot hole until it has completed its tapping operation.
7. Move the control lever into its center/neutral position until the spindle has come to a complete stop.
8. Move the control lever into its reverse direction so the tap unscrews itself from the hole it has just threaded.

Using the control lever

The four-position control lever is located on the left hand side of the drill head console. See Figs. 1 and 3.

The control lever can move up or down, backward or forward, or can be left in its most central, OFF or *neutral* position so no functions are under its control power.

The control lever moves up or down to move the arm up or down when positioning the tooling over the work piece. This ability to control the height of the arm is available when:

1. The main power to the machine is ON at its branch service panel.
2. The emergency STOP switch is set to its ON mode.
3. The Control ON/OFF switch (lower left hand side of the face of the drill head, see Fig. 1) pushed ON.
4. The column and arm UNLOCK button (right hand side of the drill head -- see Fig. 1) is pressed to unlock the machine locks. See page 6.

The control lever does not return to neutral when it is released. It stays in the position in which you have placed it. This means unless you return it to neutral, the arm will keep raising or lowering until it contacts one of its limit switches.

When the motor speed control switch has been set to either HI or LOW position, the control lever can be moved backward or forward to turn the spindle drive motor ON and control the direction of rotation of the spindle. The control lever is not spring loaded to return to the neutral or OFF position when you

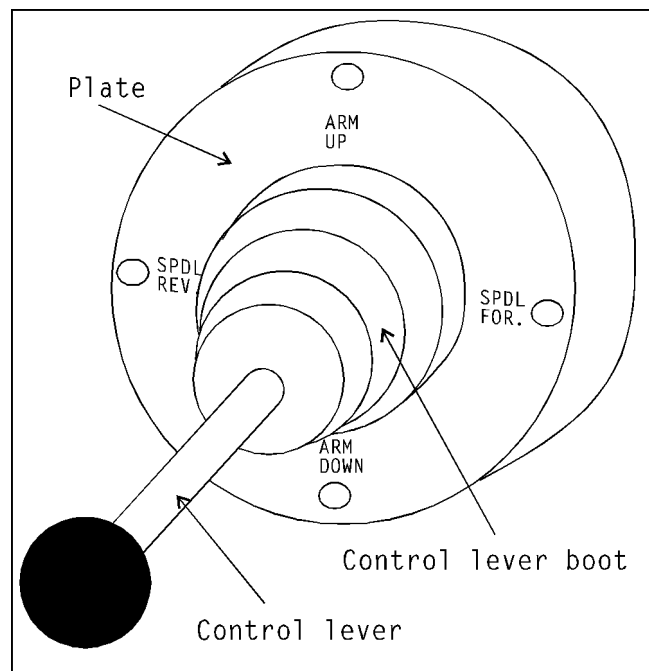

Figure 3: Control lever for spindle and arm.

release it. Rather, the lever stays in the position in which you put it when you are controlling the spindle. There is no need to hold it in position to keep the spindle running.

All of these functions are clearly labeled on the plate which surrounds the control lever and boot.

Periodic maintenance

The only maintenance for the Model 1230 is lubrication and changing of the coolant according to the schedule, below.

Item	Location	Action	Interval	Lubricant
Oiling cup	Top and bottom of arm at column	Add lubricant with lube gun	Daily	Mobil Vactra oil AA
Oiling cup	Top of drill head	Add lubricant with lube gun	Daily	Mobil Vactra oil AA
Oiling cups	Right hand side of drill head	Add lubricant with lube gun	Daily	Mobil Vactra oil AA
Arm raising worm	Rear of column	Oil using lube gun	Daily	Mobil Vactra oil AA
Sight glass	On drill head	Check for level -- fill through pipe plug hole top of drill head	Daily	Mobil Vactra oil AA
Lift chains	On rear of arm	Lubricate with lube gun	Weekly	Mobil Vactra oil AA
Ways	On arm	Lubricate with lube gun	Twice daily	Mobil Vactra oil AA
Coolant	In tank	Monitor for cleanliness and efficiency. Replace when dirty or when cutting becomes inefficient	When cutting	
Oil fitting	On quill	Lubricate with gun	Daily	Mobil Vactra oil AA
Rack	On arm	Lubricate with gun	Every 3 days	Mobil Vactra oil AA

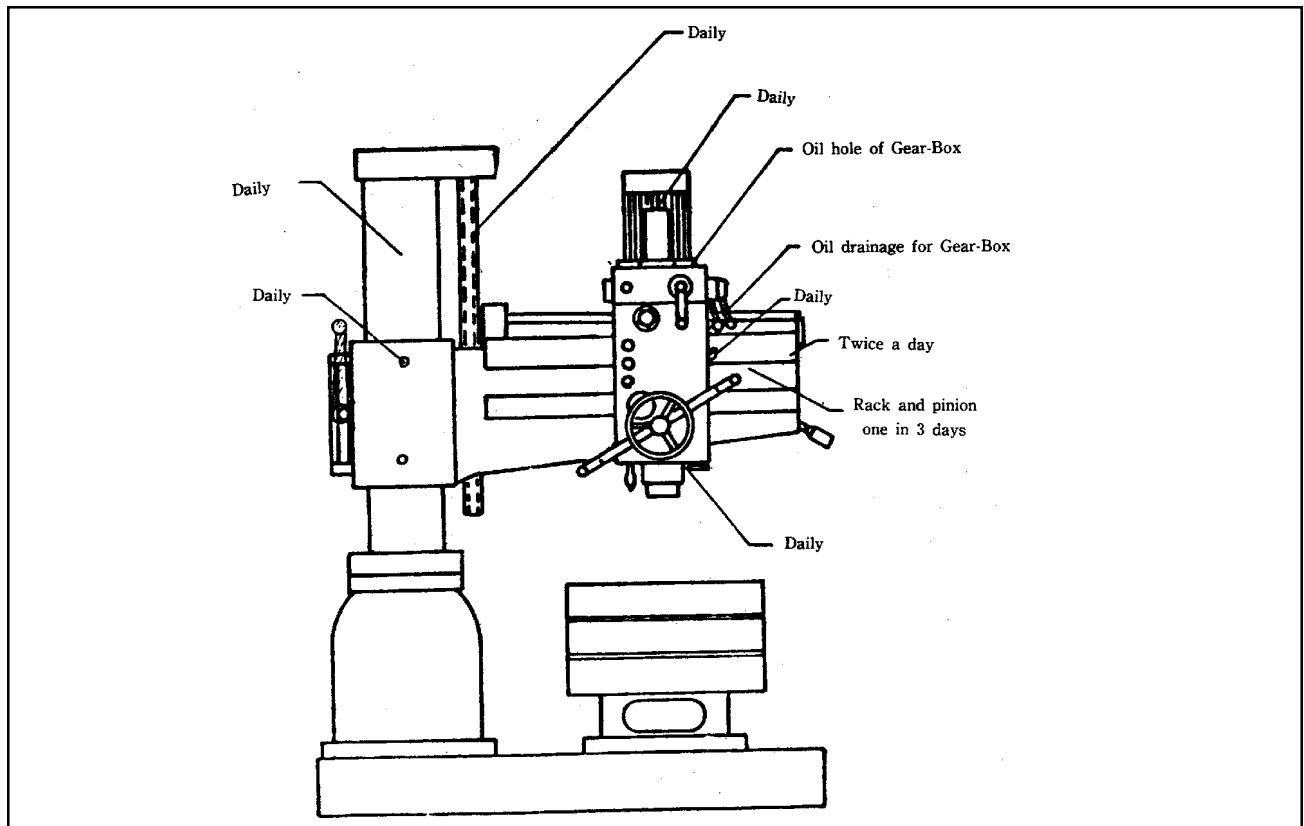

Figure 4: Lubrication diagram

Machine set-up

1. Lift the drill press from its shipping skid according to the diagram, below.

2. Secure the drill press to the floor

The drill press MUST be anchored to the floor according to the layout diagram below.

Failure to anchor the machine properly, according to these diagrams, could result in the machine tipping over and consequent damage to the machine and possible injury or DEATH to the machine operator and bystanders.

3. Connect the electrical service branch to the machine according to the instructions which follow under *Electrical*. This work should be done only by a qualified and licensed electrician who is familiar with machine service and national and local codes.

4. Wipe the surfaces of the machine which might be coated with protective coating using mineral spirits or other nonflammable solvent.

5. Look in the sight glasses on the machine to be certain they are filled to their level lines. If low, add fluid as necessary according to instructions in *Lubrication*.

6. Perform a lubrication check at all points recommended in the table in *Periodic Maintenance*.

7. Use instructions in the *Operating Instructions* section of this manual to check all operating functions of the drill press. If coolant is being used in this machine, put coolant in the sump and test coolant delivery, as well.

8. When all of the above operations are complete the machine is ready for service.

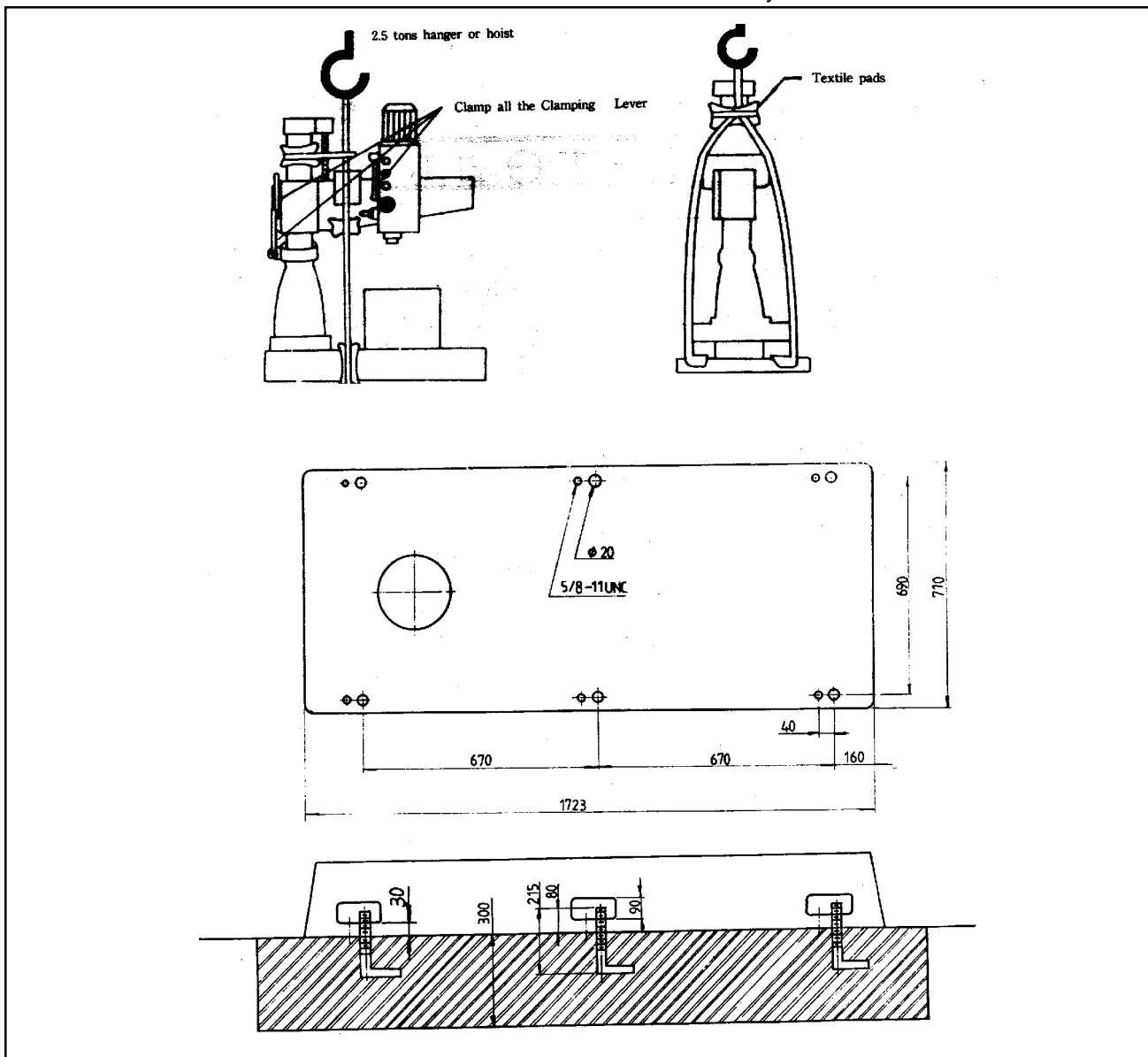

Figure 5: Machine lifting, transport and anchoring diagrams -- all dimensions in mm, except anchor bolts (inches, as noted)

Caution

Electrical set-up should be performed only by a licensed electrician who is familiar with national and local electrical codes.

The Model 1230 is shipped after testing all functions and circuits under electrical power specified for the machine and motors. The only hook-up requirement should be for correct connection to an appropriate cutout on an appropriate service branch.

Where the following instructions do not agree with local electrical codes and procedures, the applicable codes and procedures should be followed, exclusively.

to the ON position.

6. **Observe the direction of rotation of the coolant pump.** You can see the pump shaft rotate on top of the pump at the rear of the drill press. There will be an arrow cast into the pump, and the shaft should be rotating in the direction of the arrow. If the shaft is rotating in the wrong direction, the power is connected, backwards. Correct as follows:
7. Disconnect power to the machine by turning it off at the cutout box.
8. Reverse *any two* of the power lead connections.
9. Repeat steps 4, 5, and 6, above, and you should observe the pump shaft turning in the correct direction. The electrical service to the machine is now complete.

Electrical

Electrical branch service

The machine is wired for either a 230 or 460 3-phase service branch. The cable supplying the drill press will be tagged with the voltage at which the machine was tested and corresponding to the customer's order.

If the tag has been lost, it will be necessary for you to open the electrical cabinet on the rear of the drill press and examine the connections on the transformer found inside the box. The transformer can be connected to either a 230 or 460 volt source and its taps are labeled for voltage. By locating the source tap on the transformer you will be able to determine the branch voltage required.

A service disconnect is recommended. The use of fuses or circuit breakers for each of the voltage supply wires is required. Use fuses or circuit breakers which are appropriate to the voltage for the motor system delivered.

A positive cut-out/lock-out lever or rocker switch should be located on the outside of the service disconnect to allow the machine operator to disconnect the machine from the branch circuit when working with tooling on the machine.

To connect the branch to the drill press

1. Disconnect the service branch to the machine by moving the lever or rocker switch on the cutout box to OFF.
2. Connect the green wire (or green with white trace) to the branch ground.
3. Connect the remaining three wires in the cable (labeled R,S and T) to the three power lines in the branch.
4. Turn the power to the machine ON at the cutout box.
5. Turn the coolant pump power switch (See Fig. 1)

Wiring diagram

A wiring diagram for the drill press is found on the facing page. This diagram is for reference by your licensed installing or servicing electrician. In addition to using a licensed electrician for connection to the drill press service branch, the servicing of components and circuits inside the control box should be serviced only by a qualified electrician. This includes fuse replacement, if required. If any of these fuses, upon replacement, should continue to fail at short service intervals, the electrician should be asked to check all machine components for excessive loads, short circuits or other failures.

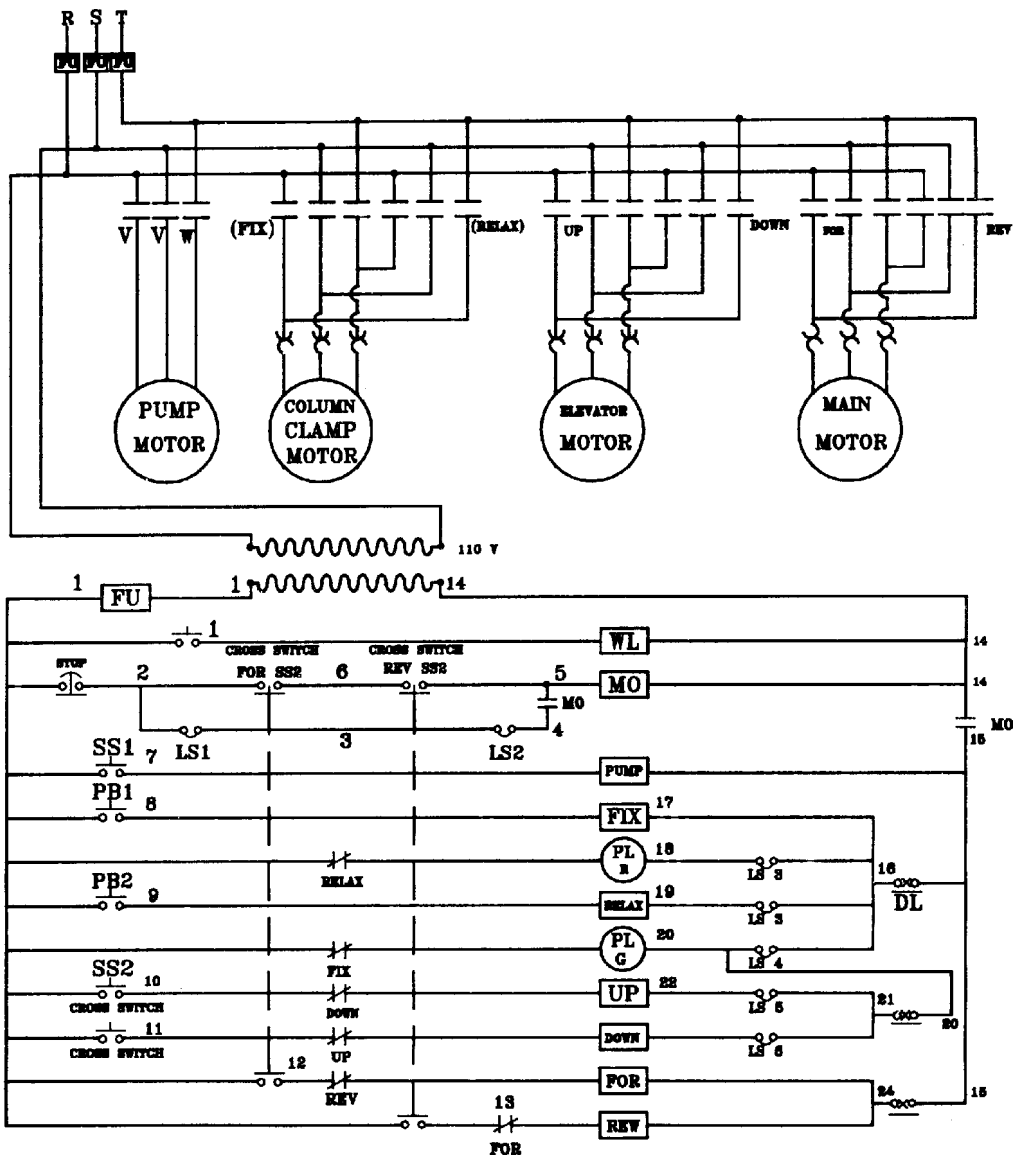

Figure 6: Wiring diagram

Replacement Parts

This section provides exploded view illustrations that show the replacement parts for the Wilton 4 foot arm, Model 1230 Radial Drill. Also provided are parts listings that provide part number, description, and quantity. The item numbers shown on the illustration relate to the item number on the facing page of the parts listing.

Order replacement parts from:

Wilton Corporation
300 South Hicks Road
Palatine, IL 60067
TEL: 1-888-594-5866
FAX: 1-800-626-9676

Identify the replacement part by the part number shown in the parts listing. Be sure to include the model number and serial number of your machine when ordering replacement parts to assure that you will receive the correct part.

Exploded View - Column and Base

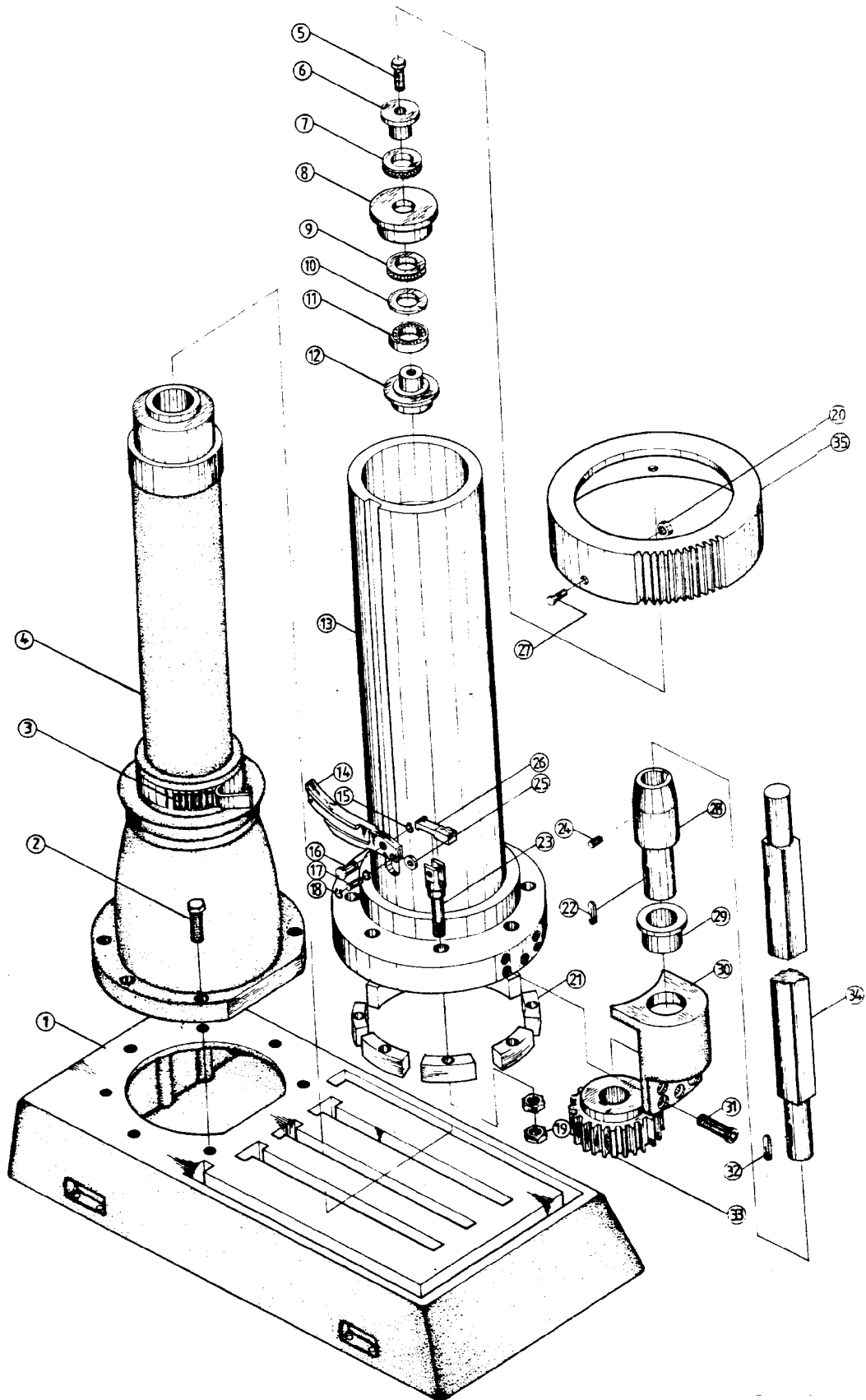

Parts List - Column and Base

Ref no.	Wilton part no.	Description
1	5232911	Base
2	5232921	Bolt
3	5232931	Needle bearing
4	5232941	Internal column
5	5232951	Bolt
6	5232961	Top bearing cover
7	5232971	Thrust bearing
8	5232981	Fixed brg. housing
9	5232991	Thrust bearing
10	5233011	Washer
11	5233021	Ball bearing
12	5233031	Top bearing cover
13	5233041	External column
14	5233051	Slip blocket
15	5233061	Retaining ring
16	5233071	Slip bar
17	5233081	Fixing shaft
18	5233091	Retaining ring
19	5233111	Nut
20	5233121	Roller
21	5233131	Wedge
22	5233141	Key
23	5233151	Elevating shaft
24	5233161	Screw
25	5233171	Roller
26	5233181	Ship blocket
27	5233191	Slip bar
28	5233211	Shaft
29	5233221	Bushing
30	5233231	Locking blocket
31	5233241	Bolt
32	5233251	Key
33	5233261	Clamping gear
34	5233271	Locking shaft
35	5233281	Locking cover

Parts List - Column Gear Box

Ref no.	Wilton part no.	Description
1	5235751	Bolt
2	5235761	Washer
3	5235771	Bushing
4	5235781	Round bar
5	5235791	Plain washer
6	5235811	Nut
7	5235821	Nut
8	5235831	Bolt
9	5235841	Chain frame
10	5235851	Screw
11	5235861	Limit switch
12	5235871	Retaining ring

Ref no.	Wilton part no.	Description
13	5235881	Needle bearing
14	5235891	Shaft
15	5235911	Retaining ring
16	5235921	Retaining ring
17	5235931	Needle bearing
18	5235941	Shaft
19	5235951	Retaining ring
20	5235961	Chain
21	5235971	Bolt
22	5235981	Chain adapter
23	5235991	Cast iron block

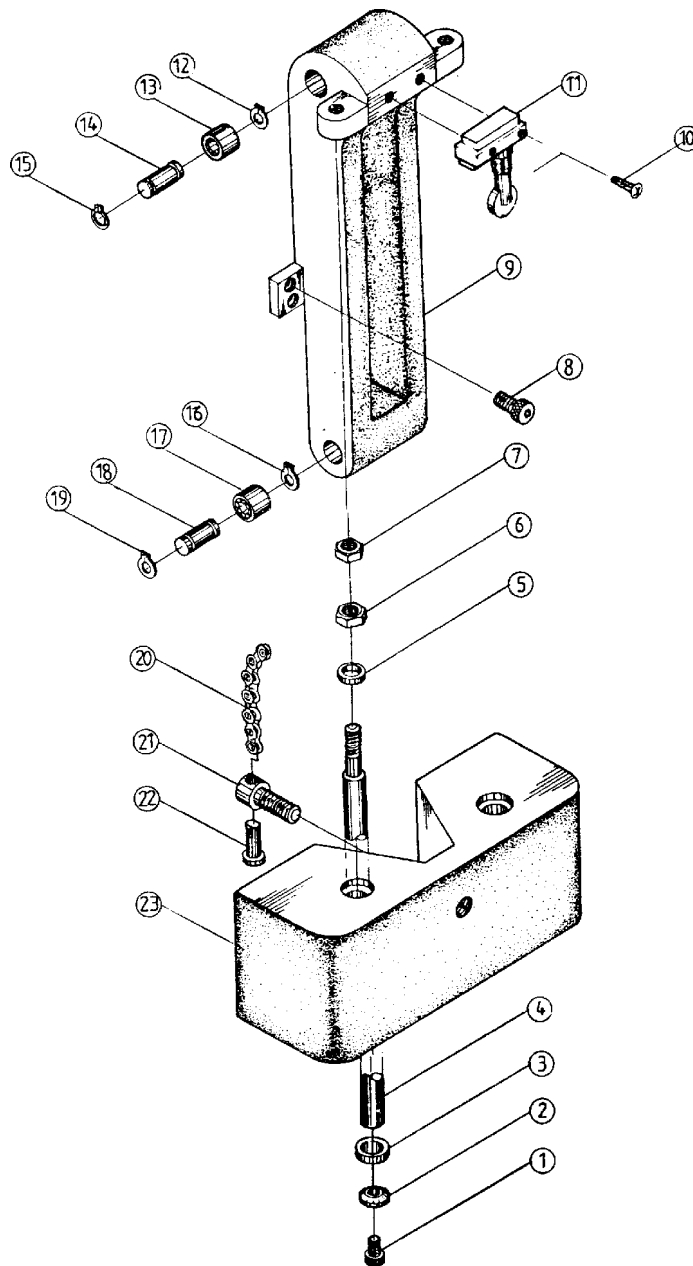

Parts List - Arm (Front)

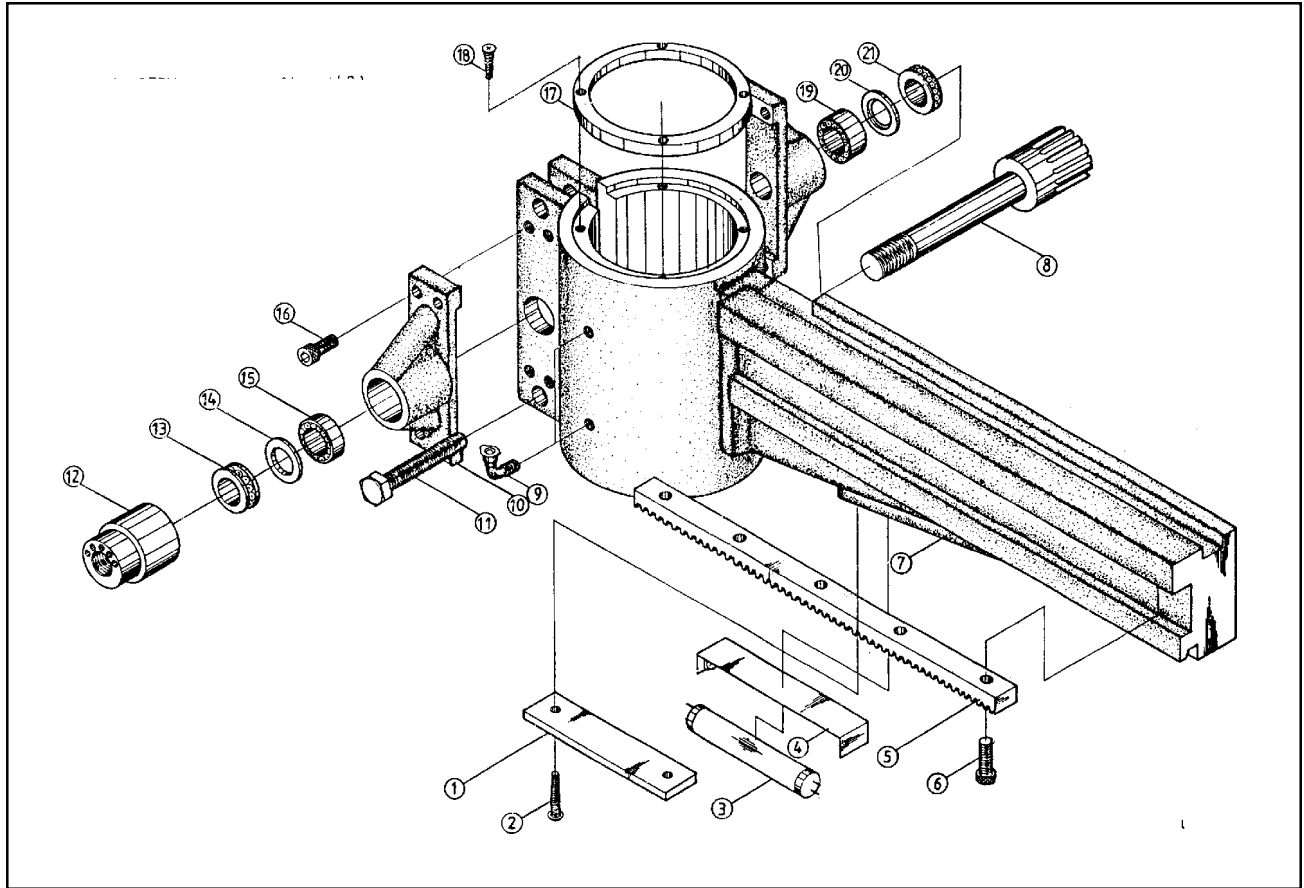

Ref no.	Wilton part no.	Description
1	5233311	Lamp cover
2	5233321	Screw
3	5233331	Lamp
4	5233341	Lamp seat
5	5233351	Arm rack
6	5233361	Bolt
7	5233371	Arm
8	5233381	Locking shaft
9	5233391	Oil fill cup
10	5233411	Fixed clamping block
11	5233421	Bolt
12	5233431	Locking nut
13	5233441	Thrust bearing
14	5233451	Plain washer
15	5233461	Ball bearing
16	5233471	Bolt
17	5233481	Aluminum ring
18	5233491	Screw
19	5233511	Ball bearing
20	5233521	Plain washer
21	5233531	Thrust bearing

Exploded View - Arm (Rear)

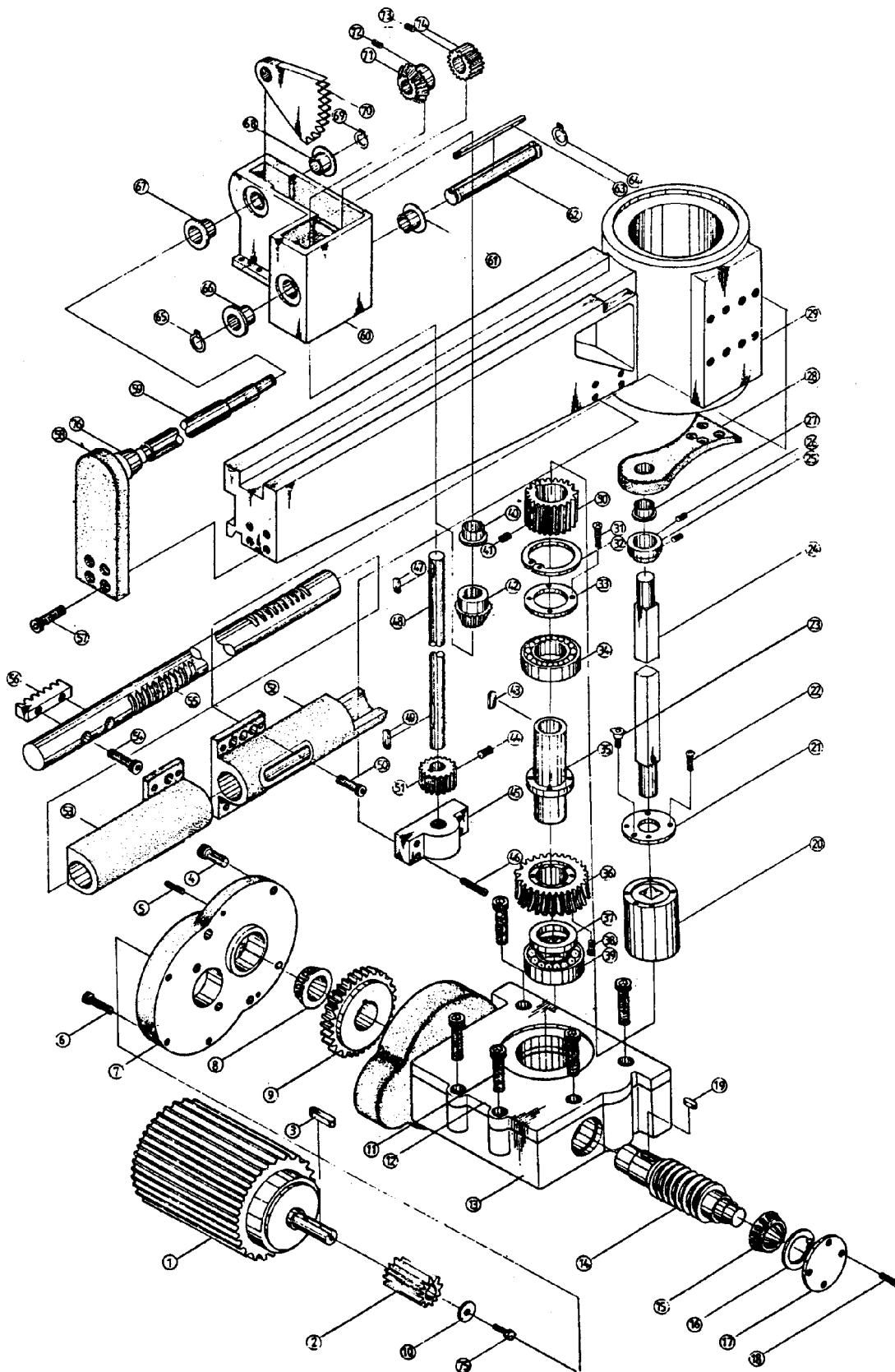

Parts List - Arm (Rear)

Ref no.	Wilton part no.	Description
1	5236011	Motor
2	5236021	Gear
3	5236031	Key
4	5236041	Bolt
5	5236051	Pin
6	5236061	Bolt
7	5236071	Upper cover
8	5236081	Taper bearing
9	5236091	Gear
10	5236111	Washer
11	5236121	Bolt
12	5236131	Gear case cover
13	5236141	Gear case
14	5236151	Worm shaft
15	5236161	Taper bearing
16	5236171	Retaining ring
17	5236181	Cover
18	5236191	Bolt
19	5236211	Key
20	5236221	Bushing
21	5236231	Cover
22	5236241	Bolt
23	5236251	Oil cup
24	5236261	Locking shaft
25	5236271	Bushing
26	5236281	Bolt
27	5236291	Bushing
28	5236311	Block
29	5236321	Arm
30	5236331	Gear
31	5236341	Bolt
32	5236351	Retaining ring
33	5236361	Cover
34	5236371	Bearing
35	5236381	Shaft
36	5236391	Worm gear
37	5236411	Plain washer
38	5236421	Bolt
39	5236431	Bearing
40	5236441	Bushing
41	5236451	Bolt
42	5236461	Gear
43	5236471	Ke
44	5236481	Bolt
45	5236491	Block
46	5236511	Bolt
47	5236521	Key
48	5236531	Shaft
49	5236541	Key

Ref no.	Wilton part no.	Description
50	5236551	Bolt
51	5236561	Gear
52	5236571	Block
53	5236581	Block
54	5236591	Bolt
55	5236611	Rack shaft
56	5236621	Rack
57	5236631	Bolt
58	5236641	Block
59	5236651	Shaft
60	5236661	Gearbox
61	5236671	Bushing
62	5236681	Shaft
63	5236691	Key
64	5236711	Retaining ring
65	5236721	Retaining ring
66	5236731	Bushing
67	5236741	Bushing
68	5236751	Bushing
69	5236761	Retaining ring
70	5236771	Gear
71	5236781	Gear
72	5236791	Bolt
73	5236811	Bolt
74	5236821	Gear
75	5236831	Bolt
76	5236841	Rubber tap

Parts List - Riser Mechanism

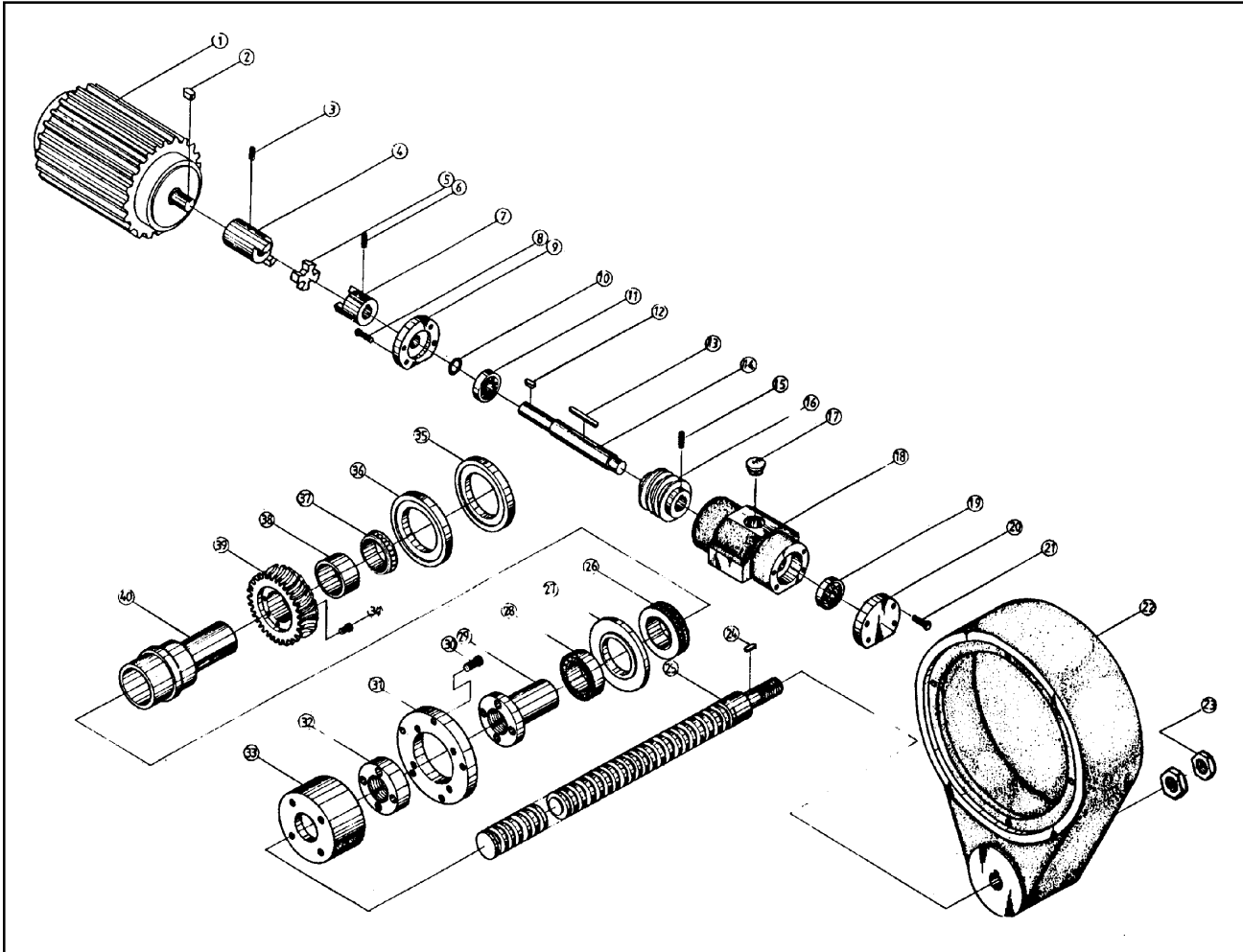

Ref no.	Wilton part no.	Description
1	5232451	Motor
2	5232461	Key
3	5232471	Screw
4	5232481	Adapter
5	5232491	Plastic sheet
6	5232511	Screw
7	5232521	Adapter
8	5232531	Bolt
9	5232541	Cover
10	5232551	Oil seal
11	5232561	Bearing
12	5232571	Key
13	5232581	Key
14	5232591	Shaft
15	5232611	Screw
16	5232621	Worm shaft
17	5232631	Oil level gage
18	5232641	Worm housing
19	5232651	Bearing
20	5232661	Bearing cover

Ref no.	Wilton part no.	Description
21	5232671	Bolt
22	5232681	Top cap
23	5232691	Screw nut
24	5232711	Key
25	5232721	Lead screw
26	5232731	Thrust bearing
27	5232741	Collar
28	5232751	Ball bearing
29	5232761	Brass sleeve
30	5232771	Bolt
31	5232781	Cover
32	5232791	Safety device nut
33	5232811	Safety device cover
34	5232821	Bolt
35	5232831	Collar
36	5232841	Collar
37	5232851	Tapered bearing
38	5232861	Collar
39	5232871	Worm gear
40	5232881	Up/Down rolling shaft

Exploded View - Head

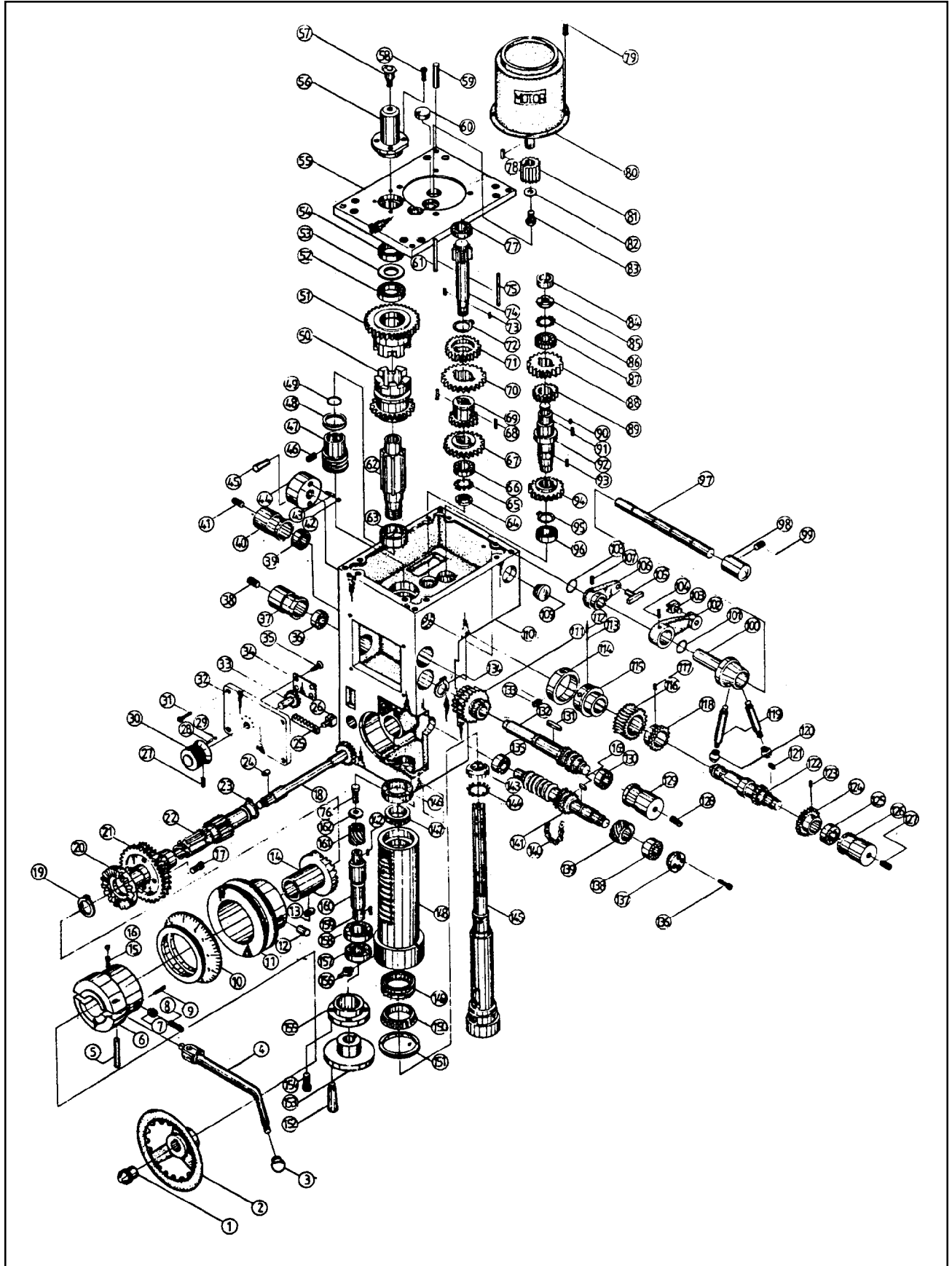

Parts List - Head

Ref no.	Wilton part no.	Description
1	5233551	Hand wheel lock nut
2	5233561	Hand wheel
3	5233571	Plastic knob
4	5233581	Feed handle
5	5233591	Pin
6	5233611	Clutch housing
7	5233621	Stopper cotter
8	5233631	Spring
9	5233641	Pin
10	5233651	Dial
11	5233661	Dial seat
12	5233671	Pin
13	5233681	Key
14	5233691	Clutch
15	5233711	Spring
16	5233721	Steel ball
17	5233731	Bolt
18	5233741	Pinion shaft
19	5233751	Retaining ring
20	5233761	Clutch
21	5233771	Worm gear
22	5233781	Gear shaft
23	5233791	Retaining ring
24	5233811	Key
25	5233821	Feed speed change rack
26	5233831	Copper block
27	5233841	Screw
28	5233851	Spring
29	5233861	Steel ball
30	5233871	Feed speed selector
31	5233881	Bolt
32	5233891	Gear box front plate
33	5233911	Feed speed change gear
34	5233921	Plate
35	5233931	Screw
36	5233941	Ball bearing
37	5233951	Bushing
38	5233961	Bolt
39	5233971	Ball bearing
40	5233981	Bushing
41	5233991	Bolt
42	5234011	Steel ball
43	5234021	Spring
44	5234031	Speed change shaft
45	5234041	Taper pin
46	5234051	Screw
47	5234061	Shaft
48	5234071	Oil seal
49	5234081	Oil seal
50	5234091	Clutch lower gear
51	5234111	Clutch upper gear
52	5234121	Ball bearing
53	5234131	Washer
54	5234141	Ball bearing

Ref no.	Wilton part no.	Description
55	5234151	Gear box cover
56	5234161	Aluminum cover
57	5234171	Oil cup
58	5234181	Bolt
59	5234191	Taper pin
60	5234211	Gasket
61	5234221	Key
62	5234231	Spindle shaft
63	5234241	Ball bearing
64	5234251	Lock nut
65	5234261	Lock washer
66	5234271	Ball bearing
67	5234281	Gear
68	5234291	Key
69	5234311	Gear
70	5234321	Gear
71	5234331	Gear
72	5234341	Retaining ring
73	5234351	Key
74	5234361	Gear shaft
75	5234371	Key
76	5234381	Gear shaft
77	5234391	Ball bearing
78	5234411	Key
79	5234421	Bolt
80	5234431	Motor
81	5234441	Gear
82	5234451	Plain washer
83	5234461	Bolt
84	5234471	Bushing
85	5234481	Lock nut
86	5234491	Lock washer
87	5234511	Ball bearing
88	5234521	Gear
89	5234531	Gear
90	5234541	Key
91	5234551	Key
92	5234561	Gear shaft
93	5234571	Key
94	5234581	Gear
95	5234591	Retaining ring
96	5234611	Ball bearing
97	5234621	Shaft
98	5234631	Shaft cover
99	5234641	Screw
100	5234651	3-step change lvr. adapter
101	5234661	Oil seal
102	5234671	Speed change rocker arm
103	5234681	Copper block
104	5234691	Bolt
105	5234711	Copper block
106	5234721	Speed change rocker arm
107	5234731	Screw
108	5234741	Oil seal

Parts List - Head

Ref no.	Wilton part no.	Description
109	5234751	Oil level gage
110	5234761	Gear box
111	5234771	Gear
112	5234781	Spring
113	5234791	Steel ball
114	5234811	Sleeve
115	5234821	Worm gear sleeve
116	5234831	Worm gear
117	5234841	Bolt
118	5234851	Gear
119	5234861	3-step speed change lever
120	5234871	Plastic knob
121	5234881	Key
122	5234891	Lower feed gear shaft
123	5234911	Screw
124	5234921	Middle gear
125	5234931	Ball bearing
126	5234941	Bushing
127	5234951	Bolt
128	5234961	Bolt
129	5234971	Bushing
130	5234981	Ball bearing
131	5234991	Key
132	5235011	Lower feed gear shaft
133	5235021	Screw
134	5235031	Retaining ring
135	5235041	Ball bearing
136	5235051	Bolt
137	5235061	Bearing cover
138	5235071	Ball bearing
139	5235081	Helical tooth
140	5235091	Chain
141	5235111	Sprocket shaft
142	5235121	Key
143	5235131	Lock nut
144	5235141	Lock washer
145	5235151	Spindle
146	5235161	Ball bearing
147	5235171	Thrust bearing
148	5235181	Quill
149	5235191	Needle bearing
150	5235211	Taper bearing
151	5235221	Set screw
152	5235231	Handle
153	5235241	Handle wheel
154	5235251	Bolt
155	5235261	Bearing housing
156	5235271	Grease inlet
157	5235281	Ball bearing
158	5235291	Ball bearing
159	5235311	Key
160	5235321	Shaft
161	5235331	Helical tooth
162	5235341	Plain washer
163	5235351	Key

Parts List - Rear of Head

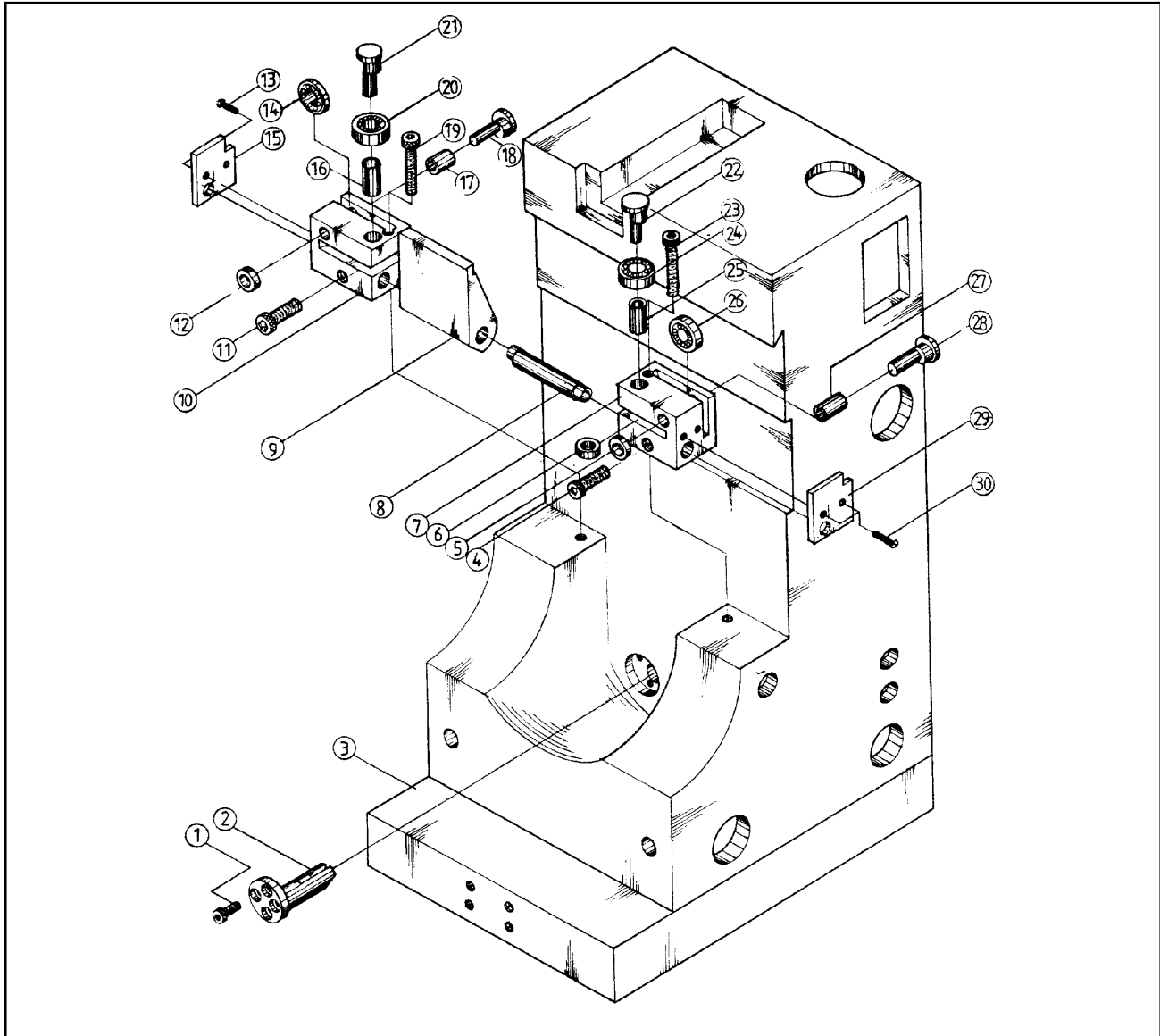

28

Ref no.	Wilton part no.	Description
1	5235411	Bolt
2	5235421	Eccentric shaft
3	5235431	Gear box
4	5235441	Bolt
5	5235451	Adjustable collar
6	5235461	Adjustable collar
7	5235471	Bearing bracket
8	5235481	Cam shaft
9	5235491	Cam shaft sleeve
10	5235511	Bearing bracket
11	5235521	Bolt
12	5235531	Adjustable collar
13	5235541	Bolt
14	5235551	Bearing
15	5235561	Aluminum plate

Ref no.	Wilton part no.	Description
16	5235571	Bushing
17	5235581	Bushing
18	5235591	Adjustable cam
19	5235611	Bolt
20	5235621	Bearing
21	5235631	Adjustable cam
22	5235641	Adjustable cam
23	5235651	Bolt
24	5235661	Bearing
25	5235671	Bushing
26	5235681	Bearing
27	5235691	Bushing
28	5235711	Adjustable cam
29	5235721	Aluminum plate
30	5235731	Bolt

Parts list - Flood Coolant System

Ref no.	Wilton part no.	Description
1	5232251	Fixed blade
2	5232261	Cross screw
3	5232271	Hose
4	5232281	HH Screw
5	5232291	Coolant pump
6	5232311	Fitting
7	5232321	Elbow
8	5232331	Fitting
9	5232341	Elbow

Ref no.	Wilton part no.	Description
10	5232351	Tube sleeve
11	5232361	Tube sleeve
12	5232371	Tube
13	5232381	Screw
14	5232391	Screw
15	5232411	Fitting
16	5232421	Brass valve
17	5232431	Coolant hose

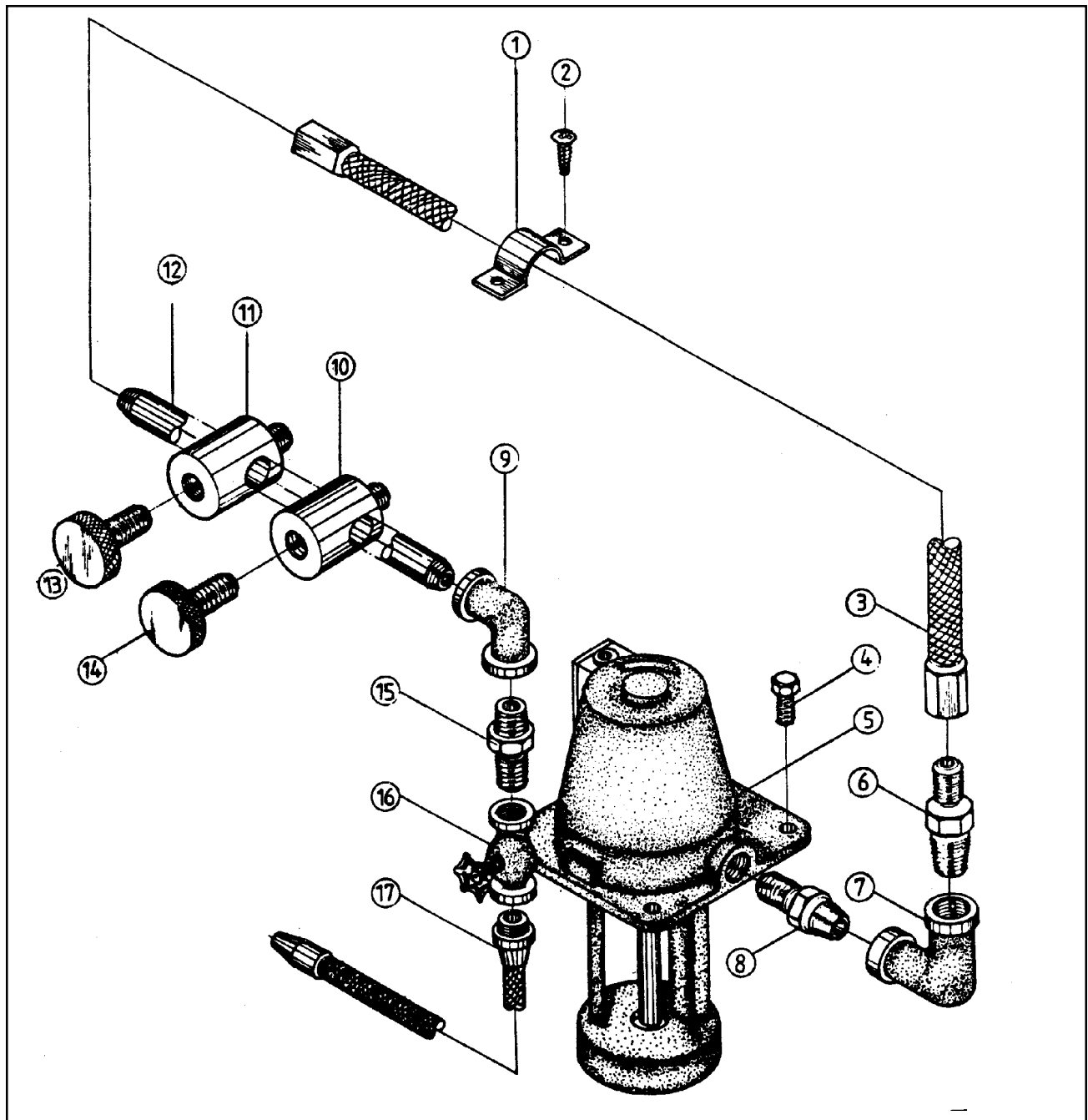

Notes:

Wilton Corporation
300 South Hicks Road
Palatine, IL 60067
TEL: 1-888-594-5866
FAX: 1-800-626-9676