

J E T[®]

WMH | TOOL GROUP

Operating Instructions and Parts Manual SMHX Series Hand Chain Hoists



WMH TOOL GROUP

2420 Vantage Drive
Elgin, Illinois 60123
Ph.: 800-274-6848
www.wmhtoolgroup.com

Part No. M-121704
Revision A 4/05
Copyright © WMH Tool Group

This manual has been prepared for the owner and operators of a JET SMHX Chain Hoist. Its purpose, aside from machine operation, is to promote safety using accepted operating and maintenance procedures. To obtain maximum life and efficiency from your chain hoist and to aid in using it safely, please read this manual thoroughly and follow the instructions carefully.

Warranty and Service

WMH Tool Group warrants every product it sells. If one of our tools needs service or repair, one of our Authorized Repair Stations located throughout the United States can provide quick service or information.

In most cases, a WMH Tool Group Repair Station can assist in authorizing repair work, obtaining parts, or perform routine or major maintenance repair on your JET product.

For the name of an Authorized Repair Station in your area, please call 1-800-274-6848, or visit our web site at www.wmhtoolgroup.com

More Information

Remember, WMH Tool Group is consistently adding new products to the line. For complete, up-to-date product information, check with your local WMH Tool Group distributor, or visit our web site at www.wmhtoolgroup.com

WMH Tool Group Warranty

WMH Tool Group makes every effort to assure that its products meet high quality and durability standards and warrants to the original retail consumer/purchaser of our products that each product be free from defects in materials and workmanship as follows: 1 YEAR LIMITED WARRANTY ON ALL PRODUCTS UNLESS SPECIFIED OTHERWISE. This Warranty does not apply to defects due directly or indirectly to misuse, abuse, negligence or accidents, normal wear-and-tear, repair or alterations outside our facilities, or to a lack of maintenance.

WMH TOOL GROUP LIMITS ALL IMPLIED WARRANTIES TO THE PERIOD SPECIFIED ABOVE, BEGINNING FROM THE DATE THE PRODUCT WAS PURCHASED AT RETAIL. EXCEPT AS STATED HEREIN, ANY IMPLIED WARRANTIES OR MERCHANTABILITY AND FITNESS ARE EXCLUDED. SOME STATES DO NOT ALLOW LIMITATIONS ON HOW LONG THE IMPLIED WARRANTY LASTS, SO THE ABOVE LIMITATION MAY NOT APPLY TO YOU. IN NO EVENT SHALL WMH TOOL GROUP BE LIABLE FOR DEATH, INJURIES TO PERSONS OR PROPERTY, OR FOR INCIDENTAL, CONTINGENT, SPECIAL, OR CONSEQUENTIAL DAMAGES ARISING FROM THE USE OF OUR PRODUCTS. SOME STATES DO NOT ALLOW THE EXCLUSION OR LIMITATION OF INCIDENTAL OR CONSEQUENTIAL DAMAGES, SO THE ABOVE LIMITATION OR EXCLUSION MAY NOT APPLY TO YOU.

To take advantage of this warranty, the product or part must be returned for examination, postage prepaid, to an Authorized Repair Station designated by our office. Proof of purchase date and an explanation of the complaint must accompany the merchandise. If our inspection discloses a defect, we will either repair or replace the product at our discretion, or refund the purchase price if we cannot readily and quickly provide a repair or replacement. We will return the repaired product or replacement at WMH Tool Group's expense, but if it is determined there is no defect, or that the defect resulted from causes not within the scope of WMH Tool Group's warranty, then the user must bear the cost of storing and returning the product. This warranty gives you specific legal rights; you may also have other rights, which vary from state to state.

WMH Tool Group sells through distributors only. Members of the WMH Tool Group reserve the right to effect at any time, without prior notice, alterations to parts, fittings and accessory equipment, which they may deem necessary for any reason whatsoever.

Table of Contents

Warranty and Service	2
Table of Contents	3
Warning.....	4
Introduction.....	5
Specifications	5
Prior to Operation	6
Hooking the Load.....	7
Raising the Load.....	7
Cutting and Installing Hand Chain	8
Replacing Load Chain.....	8
Installing Load Chain.....	9
Allowable Limits for Load Chain and Hooks.....	12
Replacement Parts	12
SMHX Chain Hoist	13
Parts List: 1-Ton SMHX Chain Hoist.....	14
Parts List: 2-Ton SMHX Chain Hoist.....	15
Parts List: 3-Ton SMHX Chain Hoist.....	16
Parts List: 5-Ton SMHX Chain Hoist.....	17

Warnings

1. Read and understand the entire owners manual before attempting assembly or operation.
2. Read and understand the warnings posted on the tool and in this manual. Failure to comply with all of these warnings may cause serious injury and/or damage to property.
3. Replace the warning labels if they become obscured or removed.
4. Keep visitors a safe distance from the work area. **Keep children away.**
5. Give your work undivided attention. Looking around, carrying on a conversation and “horse-play” are careless acts that can result in serious injury.
6. This chain hoist is designed and intended for use by properly trained and experienced personnel only. If you are not familiar with the proper and safe operation of a chain hoist, do not use until proper training and knowledge have been obtained.
7. Do not use this chain hoist for other than its intended use. If used for other purposes, WMH Tool Group disclaims any real or implied warranty and holds itself harmless from any injury that may result from that use.
8. Do not use to lift people or loads over people.
9. Do not exceed the rated capacity of the chain hoist.
10. Do not use more than hand power to pull the hand chain.
11. Do not use the load chain as a sling; this may cause damage to the chain.
12. Always inspect the chain hoist for damage prior to use. If the chain hoist is damaged, do not use until it has been repaired or replaced.
13. Do not use more than one chain hoist to lift or move a load. If this is unavoidable, each chain hoist must have the same capacity as the load to be moved.
14. Never allow the load chain to “set” over sharp edges. All lifts must be made with straight chain that is free of obstacles.
15. If the hand chain is difficult to operate, then the load exceeds the capacity of the chain hoist. Select a chain hoist of larger capacity.
16. Do not use a chain hoist unless load is centered between top and bottom hooks.
17. Always take time to study the job to be performed and choose the safest method. Do not place yourself or other people in an unsafe position.
18. Leave all internal maintenance to a qualified WMH Tool Group repair station.
19. Replace the chain with factory replacement chain only. Do not use any other type of chain.
20. Never use the chain hoist if either hook is stretched, deformed, or has a broken or missing safety latch. Always replace the safety latch and/or the hook before placing the chain hoist back into service.
21. Understand and follow all procedures as set forth in American National Standards titled “Performance Standard for Hand Chain Manually Operated Chain Hoists.” ANSI/ASME HST-2M. This standard is available through the American Society of Mechanical Engineers, 345 East 47th St., NY, NY 10017.

Familiarize yourself with the following safety notices used in this manual:

CAUTION This means that if precautions are not heeded, it may result in minor injury and/or possible tool damage.

WARNING This means that if precautions are not heeded, it may result in serious injury or possibly even death.

Introduction

This manual is provided by WMH Tool Group covering the safe operation and maintenance procedures for a JET Model SMHX Series Chain Hoist. This manual contains instructions on installation, safety precautions, general operating procedures, maintenance instructions and parts breakdown. This tool has been designed and constructed to provide years of trouble free operation if used in accordance with instructions set forth in this manual. If there are any questions or comments, please contact either your local supplier or WMH Tool Group. WMH Tool Group can also be reached at our web site: www.wmhtoolgroup.com.

Specifications

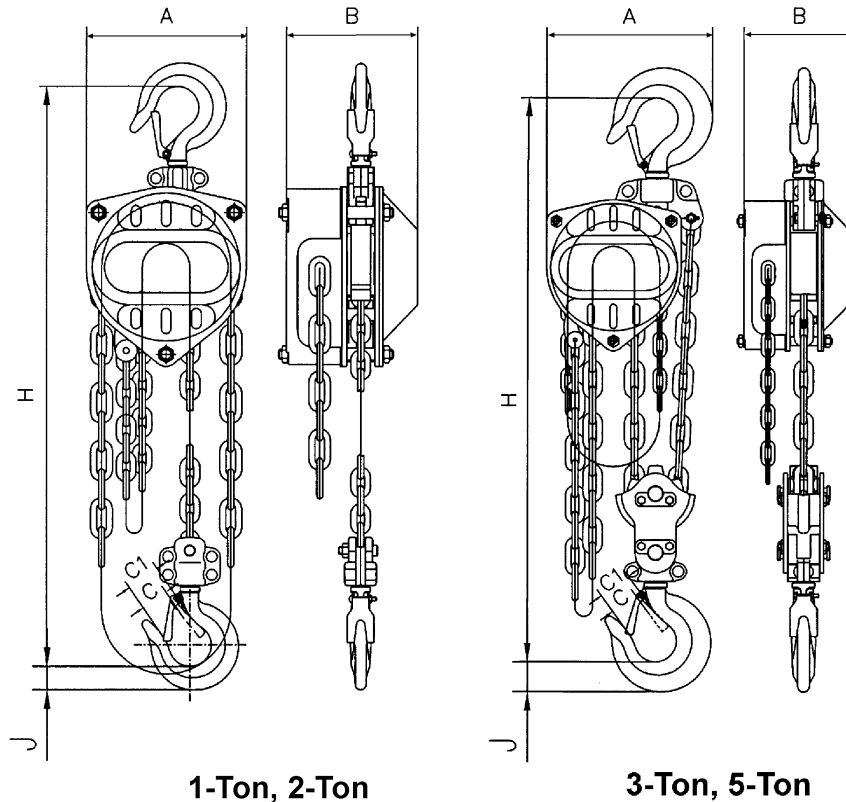

Stock Number*	Description	Rated Capacity (ton)	Standard Lift (ft.)	No. of Falls	Load Chain Dia. (mm)	Pull to Lift Capacity (lbs)	Req'd Hand Chain (ft.) to lift load 1'	Net Weight (lbs)	A (mm)	B (mm)	C (mm)	C1 (mm)	H min. (mm)	J (mm)
121704	SMHX-1T-10	1	10	1	6.3	81	38	27.56	156	132	27	30	390	25
121706	SMHX-1T-20	1	20	1	6.3	81	38	39.68	156	132	27	30	390	25
121712	SMHX-2T-10	2	10	1	8	93	70	46.30	196	146	35	38	480	34
121714	SMHX-2T-20	2	20	1	8	93	70	61.73	196	146	35	38	480	34
121716	SMHX-3T-10	3	10	2	7	88	117	57.32	220	146	39	42	610	39
121718	SMHX-3T-20	3	20	2	7	88	117	79.37	220	146	39	42	610	39
121720	SMHX-5T-10	5	10	2	9	99	172	83.77	262	170	45	48	720	45
121726	SMHX-5T-20	5	20	2	9	99	172	114.64	262	170	45	48	720	45

* The above stock numbers are representative; chain is available in other lengths. Specify required chain length when ordering.

The above specifications were current at the time this manual was published, but because of our policy of continuous improvement, WMH Tool Group reserves the right to change specifications at any time and without prior notice, without incurring obligations.

Prior to Operation

1. Support for the hoist may be hook, clevis pin, trolley, or beam clamp. Whatever method of suspension is chosen, the support components **must** be rated equal to, or greater than the capacity of the chain hoist.
2. If the chain hoist has not been used for an extended period of time, check for proper operation before putting into service.
3. The brake mechanism must be kept clean and free from dirt, water, and oil. Never allow oil to penetrate the brake mechanism. Always keep your chain hoist clean and store in a clean, dry location.
4. Although oiling the chain is not mandatory, a light coat of 30-weight oil applied periodically to the chain will create easier operation and prolong the life of the chain.
5. Check the chain for damage and elongation. Replace damaged chain before using the chain hoist.

⚠WARNING The load chain supplied with your JET chain hoist is designed, manufactured, and tested for proper fit and durability. Over a period of time, the chain may need to be replaced. For your own safety, use factory replacement chain only. Use of other than factory replacement chain may cause serious injury and/or damage to the hoist.

6. The top and bottom hooks on your JET chain hoist are designed to open to warn of an overload. Both top and bottom hooks have three indicator points cast into the hook. See Figure 1. Measurements between all three indicator points should be the same. If they are not the same, the hook must be replaced.
7. It is important to check top and bottom hooks for proper opening. If the safety latch no longer contacts the hook opening, replace the hook. **Never side load the top or bottom hook; this practice is dangerous and could lead to serious injury.**
8. If the vertical angle at the neck of the bottom or top hook reaches 10° , replace the hook (see Figure 2).

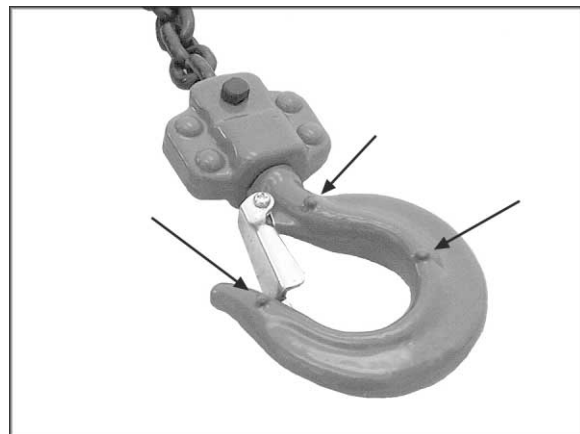

Figure 1

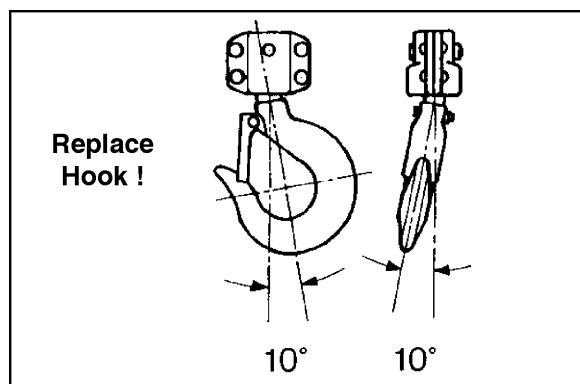

Figure 2

Hooking the Load

1. Secure the upper hook.
2. Place the bottom hook securely into the object to be lifted.
3. Place ropes or chain in the center of the bottom hook, making sure the safety latch is secure. Never load the hook in front of the safety latch. See Figure 3.
4. Avoid lifting one load with two hoists. If this is unavoidable, apply equal weight to both hoists and use hoists with the proper lift capacity. **Capacity of each hoist must be equal to the total load to be lifted.**
5. Check that the chain is not twisted at the bottom hook. All welds should face the same direction (Figure 4).
6. For hoists with two or more falls of chain, make sure the bottom hook is not turned over. This may cause the chain to twist.

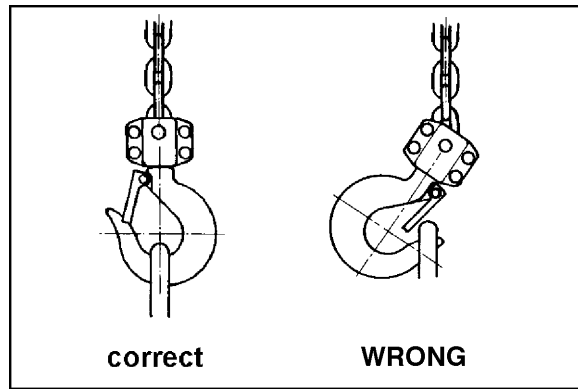

Figure 3

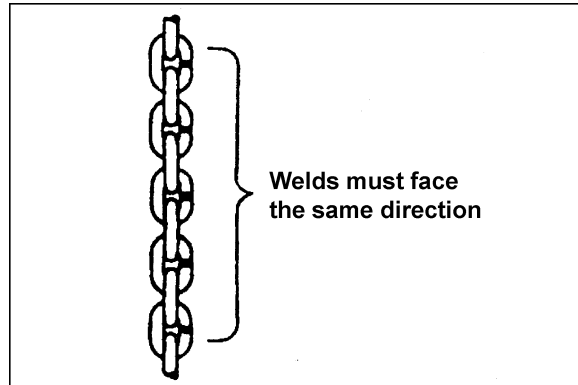

Figure 4

Raising the Load

To raise the load, pull the right side of the hand chain (A, Figure 5) clockwise.

To lower the load, pull the left side of the hand chain (B, Figure 5) counterclockwise.

Important: Make sure the hoist has an adequate length of load chain to raise or lower the load in a safe manner. Do not attempt to lower the hoist beyond its limit.

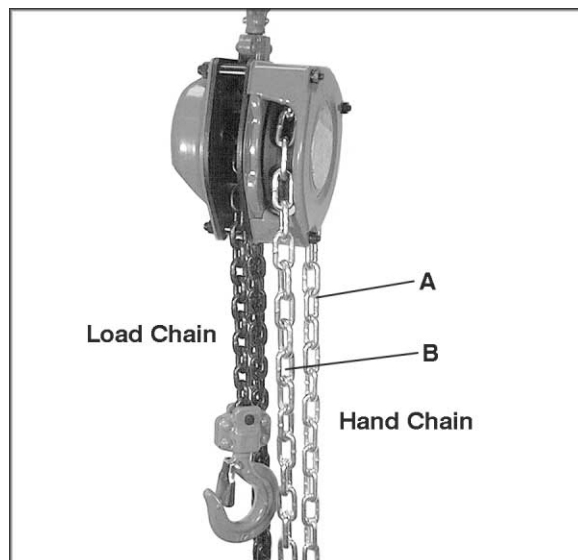

Figure 5

Cutting and Installing Hand Chain

To cut the hand chain in order to increase or shorten:

1. Insert one link lengthwise into the vise (Figure 6). Be sure that the side opposite the weld lies completely below the surface of the vise jaw (about 1/3 of a link). This prevents nicking or cutting the lower part of the link.
2. Using a hack saw, cut through the upper part of the link at the weld.
3. Loosen the link, reposition the link vertically at the edge of the vise with the level of the cut above the vise jaw (Figure 7).
4. Tighten the vise jaw.
5. Using an adjustable wrench, twist the link horizontally from front to back. (Figure 8) Open just far enough to insert (or remove) a second chain link.

Note: Chain length is now ready to lengthen or shorten.

6. Insert or remove the second end link at the opening in the first end link.
7. Using an adjustable wrench, twist the link horizontally until the link is in the original closed position. See Figure 9.

CAUTION Do not push the link inward from the curved ends. This will distort the link. Check that the link is closed and free of twist.

8. If installing entire new chain, insert the end of the hand chain into the groove at the top of the hand chain wheel (see Figure 10). Rotate the handwheel and pull the chain through.
9. Re-weld the link at the cut.
10. Grind off excess on the weld so that it is smooth.

WARNING Do not operate the hoist with a twisted, kinked or damaged load chain. Do not splice the load chain. Check the chain for excessive wear or stretch. Failure to comply may cause serious injury.

Replacing Load Chain

Over time, the load chain will wear or elongate. This can cause damage to the hoist, breakage, or non-engagement of the load sheave.

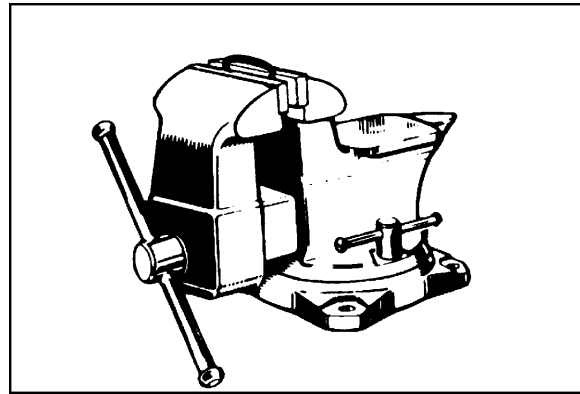

Figure 6

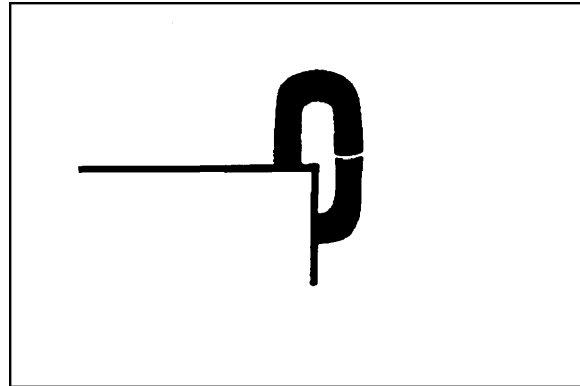

Figure 7

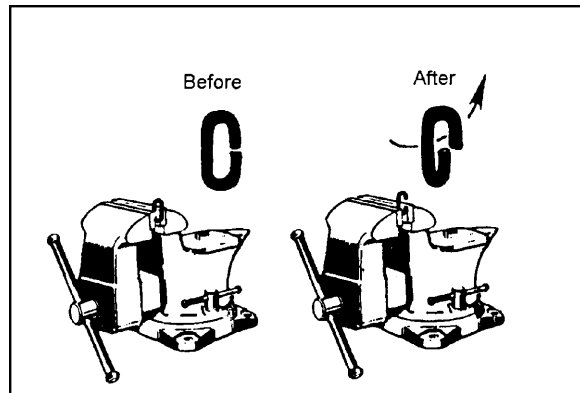

Figure 8

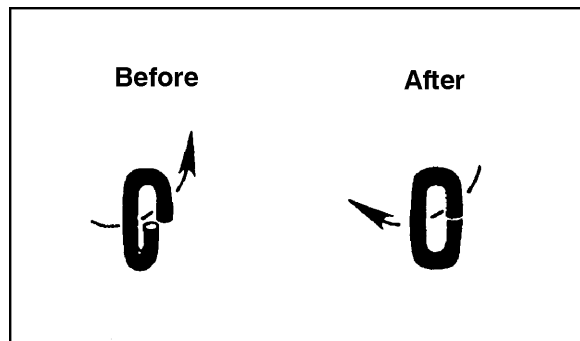

Figure 9

To inspect the load chain for wear:

1. Test the hoist under load in both the lifting and lowering directions, observing the operation of chain and sprockets. Chain should feed smoothly into and away from the sprockets.
2. If the chain binds, jumps, or is noisy, make sure it is clean and properly lubricated. If the trouble persists, inspect the chain and mating parts for wear, distortion, or other damage.
3. Clean the chain before inspection. Examine for gouges, nicks, weld splatter, corrosion, and distorted links. Slacken the chain and move adjacent links to one side, looking for wear at the contact points. If you see wear or suspect stretching, measure the chain as follows:
 - Select an unworn, unstretched length of chain (i.e. at the slack end).
 - Suspend the chain vertically under tension and, using a caliper type gauge, measure the outside length of several links about 12 to 24 inches.
 - Measure the same number of links in used sections and calculate the percentage of the increase in length.
4. If the length of used chain exceeds 2-1/2 percent of the unused chain, replace the chain.

⚠WARNING Do not add to the load chain. Replace the entire chain. Failure to comply may cause serious injury.

Installing Load Chain

To install load chain onto the load chain sprocket:

1. Position the load chain sprocket (Figure 10) by rotating the hand chain wheel (Figure 10) so that the wide and narrow grooves show in the sprocket.
2. Using a forked poker, insert the load chain into the sprocket grooves so that the chain will wind up and back over the sprocket. Welds must face away from the sprocket.
3. Rotate the hand chain wheel so that the load chain winds around the sprocket. Stop when the load chain falls six to eight inches at the back of the sprocket.
4. Remove the split pin (A, Figure 11) and the stopper pin (B, Figure 11) on the chain stopper (C, Figure 11).

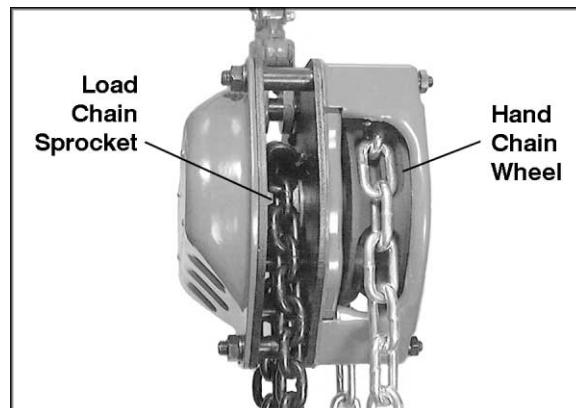

Figure 10

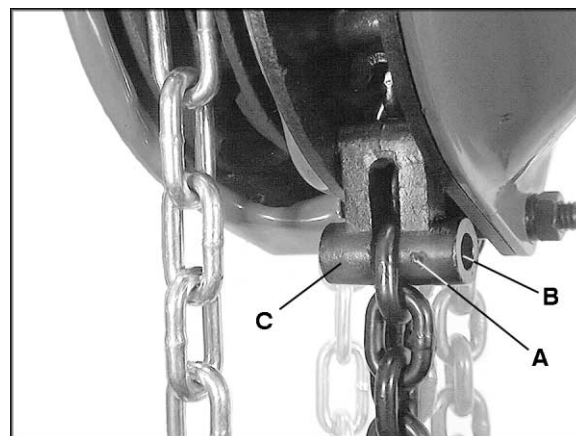

Figure 11

5. Insert the bottom chain link into the chain stopper.
6. Insert the chain stopper pin through the stopper brackets and chain link.
7. Insert the split pin through the tapered hole in the chain stopper pin and secure the split pin.

To install load chain into the **lower hook** on the **1-Ton** and **2-Ton** hoists:

1. Remove the split pin from the lower hook. See Figure 12.
2. Remove the castle nut from the chain bolt.
3. Insert the last chain link into the lower hook slot. Check that the chain is not twisted.
4. Insert the chain bolt through the lower hook slot and chain link.
5. Secure the castle nut to the end of the bolt.
6. Insert the split pin through the tapered hole of the bolt. Secure the split pin.

To install load chain into the **lower hook** on the **3-Ton** and **5-Ton** hoists:

1. After installing the load chain into the load chain sprocket, run the remaining chain through your hand to remove any twist. The last link of the chain must be in the same direction as the first. If not, cut off the last link.
2. Insert the last link into the left side pulley of the lower hook.
3. Pull the load chain through and up from the underside of the pulley.
4. Check to see the chain stopper is on the right side.
5. Insert the last link into the right hand pulley of the upper hook, moving the chain up, back, and then down. Check that the load chain is not twisted and welds face away from the pulley.
6. Insert the last link into the right side pulley of the lower hook, pulling up from the underside of the pulley.
7. Check that the load chain is not twisted.
8. Insert the last link over the left side pulley of the upper hook, moving the chain up, back, and then down.

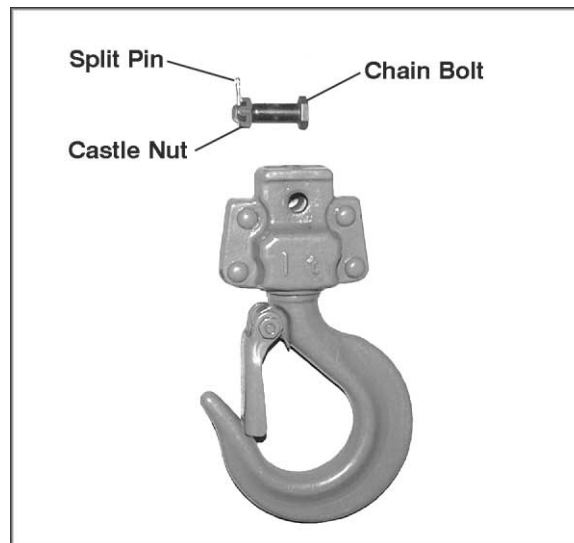



Figure 12

9. To prevent the chain from free-wheeling, insert a screwdriver securely into a link at the base of the upper pulley.
 10. Remove the split pin, castle nut, and the chain bolt in the lower hook slot.
 11. Insert the last link into the lower hook slot.
 12. Check that the load chain is not twisted.
 13. Position the chain bolt back through the lower hook slot and the last chain link.
 14. Place the castle nut onto the end of the bolt.
 15. Secure the split pin in the tapered hole of the chain bolt.
 16. Remove the screwdriver from the link at the base of the upper pulley.
7. This hoist uses special alloy hoisting chain and does not interchange with any other manufacturer. All replacement chain must be purchased from your JET distributor or from WMH Tool Group directly by calling 800-274-6848.
 8. Check and inspect the brake system frequently.
 9. Annually, the hoist should be disassembled, inspected, and cleaned by trained and experienced personnel only. Contact a WMH Tool Group authorized service center by calling your dealer or visiting our web site at wmhtoolgroup.com.
 10. After servicing, test the hoist with no load, then test the hoist with a load.

Inspection and Maintenance

Read and follow ANSI Inspection and Maintenance Instructions. Know the meaning of Frequent Inspection, Periodic Inspection, Normal Service, Heavy Service, and Severe Service. It is the customer's responsibility to understand and follow all ANSI and JET inspection and maintenance instructions.

 WARNING All repairs and adjustments are to be performed by trained and experienced personnel using procedures that are approved for the hoist system being serviced. All safety related deficiencies discovered in the inspection are to be corrected before the hoist is to be placed back into service. Check for internal damage whenever external damage has occurred. Failure to comply may cause serious injury.

1. Clean hoist after each use and oil lightly.
2. Do not drop or drag the hoist.
3. Store the hoist in a clean and dry environment.
4. Chain oiling is not mandatory but will increase the life of the chain.
5. Leave all repairs and adjustments of internal parts to qualified repair personnel.
6. Inspect the load chain and the lower hook after lifting a maximum weight load.

Allowable Limits for Load Chain and Hooks

Load Chain

Capacity	5 Links Normal	5 Links Limit
1 ton	3.74"	3.87"
2 ton	4.72"	4.89"
3 ton	4.13"	4.28"
5 ton	5.31"	5.50"

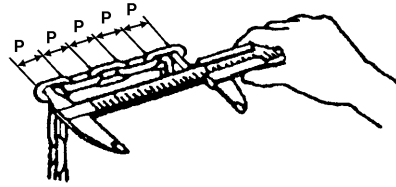

Figure 13

Carefully inspect the entire load chain. As illustrated in Figure 13, measure five consecutive links with calipers to measure the length. Check every three feet and especially where excessive wear is indicated. Any load chain that shows noticeable deformation or heat influence must be replaced with a new one. Never extend load chain by welding a second piece to the original.

Hooks (Top & Bottom)

Capacity	"A" Normal	"A" Limit
1 ton	1.18"	1.35"
2 ton	1.50"	1.73"
3 ton	1.65"	1.90"
5 ton	1.89"	2.17"

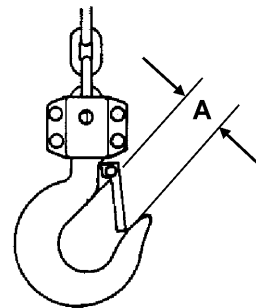

Figure 14

See Figure 14. Replace the hook when the "A" measurement is wider than "A" Limit in the table above. Never heat treat the hook or attach anything to the hook by welding.

Replacement Parts

Replacement parts are listed on the following pages. To order parts or reach our service department, call 1-800-274-6848 between 7:30 a.m. and 6:00 p.m. (CST), Monday through Friday. Having the Model Number and Serial Number of your machine available when you call will allow us to serve you quickly and accurately.

SMHX Chain Hoist

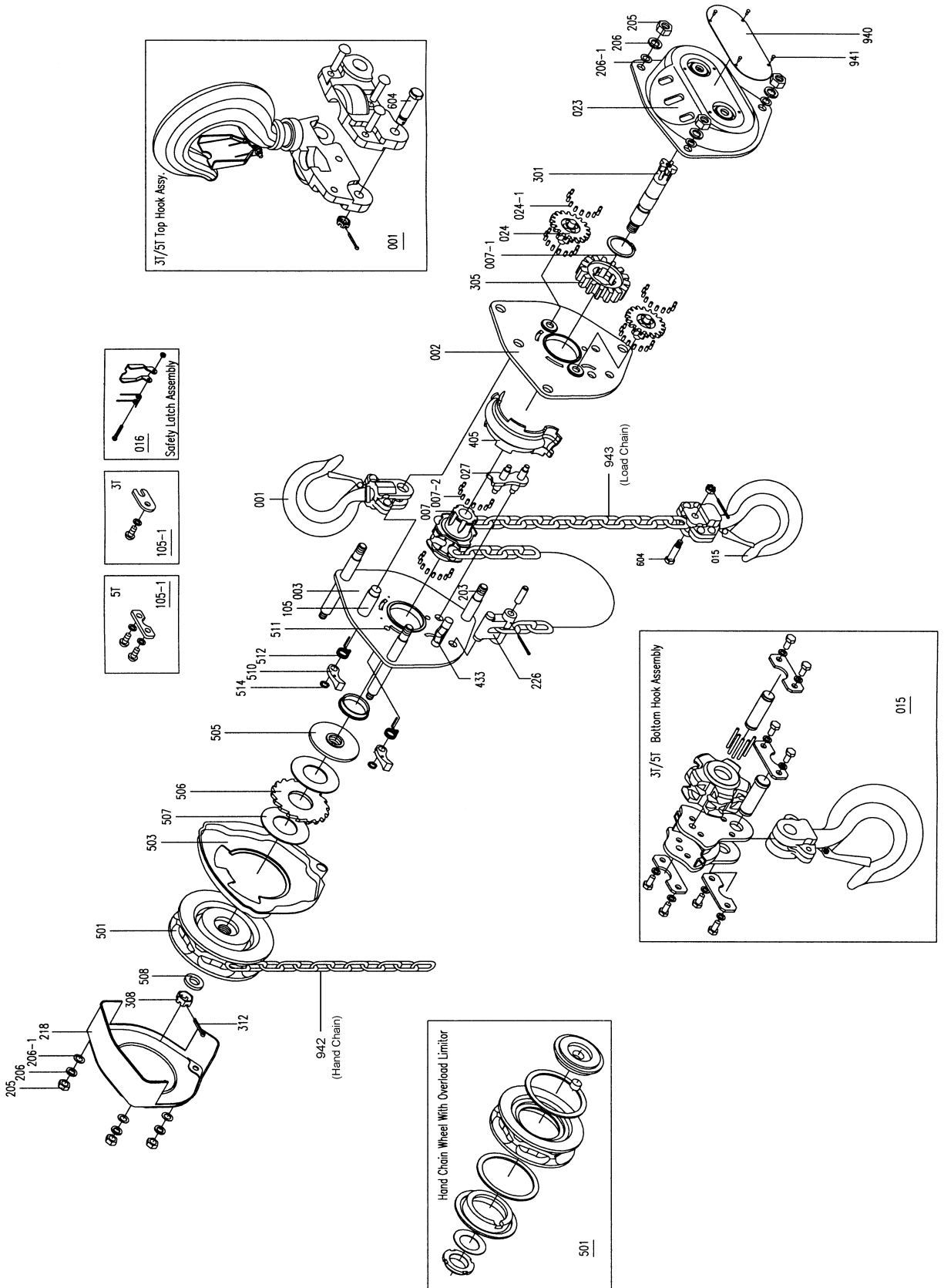

Parts List: 1-Ton SMHX Chain Hoist

Index No.	Part No.	Description	Size	Qty
001	SMH-001B	Top Hook Assembly		1
002	SMH-002B	Gear Side Plate Assembly		1
003	SMH-003B	Wheel Side Plate Assembly		1
007	SMH-007B	Load Sheave		1
007-1	SMH-007-1B	Snap Ring	M30	1
007-2	SMH-007-2B	Roller Kit	60 Rollers	1
015	SMH-015B	Bottom Hook Assembly		1
016	SMH-016B	Safety Latch Assembly		2
023	SMH-023B	Gear Case Assembly		1
024	SMH-024B	Spur Gear Assembly		2
024-1	SMH-024-1B	Roller Kit	12 Rollers	4
027	SMH-027B	Stripper Assembly		1
105	SMH-105B	Top Hook Pin		1
203	SMH-203B	Stay Bolt		3
205	SMH-205B	Cover Nut		6
206	SMH-206B	Lock Washer		6
206-1	SMH-206-1B	Flat Washer		6
218	SMH-218B	Hand Wheel Cover		1
226	SMH-226B	Anchor Plate		1
301	SMH-301B	Drive Shaft		1
305	SMH-305B	Load Gear		1
308	SMH-308B	Castle Nut		1
312	SMH-312B	Split Pin	3.2 x 25	1
405	SMH-405B	Load Sheave Cover		1
433	SMH-433B	Load Sheave Cover Pin		1
501	SMHX-501B	Hand Chain Wheel Assembly		1
503	SMH-503B	Brake Cover		1
505	SMH-505B	Disc Hub		1
506	SMH-506B	Ratchet Gear		1
507	SMH-507B	Friction Disc		2
508	SMH-508B	Check Washer		1
510	SMH-510B	Pawl		2
511	SMH-511B	Pawl Pin		2
512	SMH-512B	Pawl Spring		2
514	SMH-514B	Snap Ring	M8	1
604	SMH-604B	Chain Stop Bolt Assembly		1
940	SMHX-940B	Name Plate	1 Ton	1
941	SMH-941A	Rivet	2.5 x 6	4
942	187728	Hand Chain*	Ø 5mm	1
943	121001	Load Chain* (1-Ton)	Ø 6.3mm	1

* Specify required chain length when ordering.

Parts List: 2-Ton SMHX Chain Hoist

Index No.	Part No.	Description	Size	Qty
001	SMH-001D	Top Hook Assembly		1
002	SMH-002D	Gear Side Plate Assembly		1
003	SMH-003D	Wheel Side Plate Assembly		1
007	SMH-007D	Load Sheave		1
007-1	SMHX-007-1D	Snap Ring	M38	1
007-2	SMH-007-2C	Roller Kit	60 Rollers	1
015	SMH-015D	Bottom Hook Assembly		1
016	SMH-016D	Safety Latch Assembly		2
023	SMH-023D	Gear Case Assembly		1
024	SMH-024D	Spur Gear Assembly		2
027	SMH-027C	Stripper Assembly		1
105	SMH-105D	Top Hook Pin		1
203	SMH-203D	Stay Bolt		3
205	SMH-205D	Cover Nut		6
206	SMH-206D	Lock Washer		6
206-1	SMH-206-1D	Flat Washer		6
218	SMH-218D	Hand Wheel Cover		1
226	SMH-226C	Anchor Plate		1
301	SMH-301D	Drive Shaft		1
305	SMH-305D	Load Gear		1
308	SMH-308B	Castle Nut		1
312	SMH-312B	Split Pin	3.2 x 25	1
405	SMH-405D	Load Sheave Cover		1
433	SMH-433C	Load Sheave Cover Pin		1
501	SMHX-501D	Hand Chain Wheel Assembly		1
503	SMH-503D	Brake Cover		1
505	SMH-505D	Disc Hub		1
506	SMH-506C	Ratchet Gear		1
507	SMH-507C	Friction Disc		2
508	SMH-508B	Check Washer		1
510	SMH-510C	Pawl		2
511	SMH-511C	Pawl Pin		2
512	SMH-512B	Pawl Spring		2
514	SMH-514B	Snap Ring	M8	1
604	SMH-604D	Chain Stop Bolt Assembly		1
940	SMHX-940D	Name Plate	2 Ton	1
941	SMH-941A	Rivet	2.5 x 6	4
942	187728	Hand Chain*	Ø 5mm	1
943	121002	Load Chain* (2-Ton)	Ø 8mm	1

* Specify required chain length when ordering.

Parts List: 3-Ton SMHX Chain Hoist

Index No.	Part No.	Description	Size	Qty
001	SMH-001E	Top Hook Assembly, Complete		1
002	SMH-002E	Gear Side Plate Assembly		1
003	SMH-003E	Wheel Side Plate Assembly		1
007	SMH-007C	Load Sheave		1
007-1	SMHX-007-1D	Snap Ring	M38	1
007-2	SMH-007-2C	Roller Kit	60 Rollers	1
015	SMH-015E	Bottom Hook Assembly		1
016	SMH-016E	Safety Latch Assembly		2
023	SMH-023C	Gear Case Assembly		1
024	SMH-024C	Spur Gear Assembly		2
027	SMH-027C	Stripper Assembly		1
105	SMH-105E	Top Hook Pin		1
105-1	SMH-105-1E	Retainer Plate Assembly		1
203	SMH-203C	Stay Bolt		3
205	SMH-205B	Cover Nut		6
206	SMH-206B	Lock Washer		6
206-1	SMH-206-1B	Flat Washer		6
218	SMH-218C	Hand Wheel Cover		1
226	SMH-226C	Anchor Plate		1
301	SMH-301C	Drive Shaft		1
305	SMH-305C	Load Gear		1
308	SMH-308A	Castle Nut		1
312	SMH-312A	Split Pin	2.5 x 20	1
405	SMH-405C	Load Sheave Cover		1
433	SMH-433C	Load Sheave Cover Pin		1
501	SMHX-501C	Hand Chain Wheel Assembly		1
503	SMH-503C	Brake Cover		1
505	SMH-505C	Disc Hub		1
506	SMH-506C	Ratchet Gear		1
507	SMH-507C	Friction Disc		2
508	SMH-508A	Check Washer		1
510	SMH-510C	Pawl		2
511	SMH-511C	Pawl Pin		2
512	SMH-512B	Pawl Spring		2
514	SMH-514B	Snap Ring	M8	1
604	SMH-604E	Chain Stop Bolt Assembly		1
940	SMHX-940E	Name Plate	3 Ton	1
941	SMH-941A	Rivet	2.5 x 6	4
942	187728	Hand Chain*	Ø 5mm	1
943	121003	Load Chain* (3-Ton)	Ø 7mm	1

* Specify required chain length when ordering.

Parts List: 5-Ton SMHX Chain Hoist

Index No.	Part No.	Description	Size	Qty
001	SMH-001F	Top Hook Assembly, Complete		1
002	SMH-002F	Gear Side Plate Assembly		1
003	SMH-003F	Wheel Side Plate Assembly		1
007	SMH-007F	Load Sheave		1
007-1	SMH-007-1F	Snap Ring	M45	1
007-2	SMH-007-2F	Roller Kit	70 Rollers	1
015	SMH-015F	Bottom Hook Assembly, Complete		1
016	SMH-016F	Safety Latch Assembly		2
023	SMH-023F	Gear Case Assembly		1
024	SMH-024F	Spur Gear Assembly		2
027	SMH-027F	Stripper Assembly		1
105	SMH-105F	Top Hook Pin		1
105-1	SMH-105-1F	Retainer Plate Assembly		1
203	SMH-203F	Stay Bolt		3
205	SMH-205D	Cover Nut		6
206	SMH-206D	Lock Washer		6
206-1	SMH-206-1D	Flat Washer		6
218	SMH-218F	Hand Wheel Cover		1
226	SMH-226F	Anchor Plate		1
301	SMH-301F	Drive Shaft		1
305	SMH-305F	Load Gear		1
308	SMH-308B	Castle Nut		1
312	SMH-312B	Split Pin	3.2 x 25	1
405	SMH-405F	Load Sheave Cover		1
433	SMH-433F	Load Sheave Cover Pin		1
501	SMHX-501F	Hand Chain Wheel Assembly		1
503	SMH-503F	Brake Cover		1
505	SMH-505F	Disc Hub		1
506	SMH-506F	Ratchet Gear		1
507	SMH-507F	Friction Disc		2
508	SMH-508B	Check Washer		1
510	SMH-510F	Pawl		2
511	SMH-511F	Pawl Pin		2
512	SMH-512F	Pawl Spring		2
514	SMH-514F	Snap Ring	M9	1
604	SMH-604F	Chain Stop Bolt Assembly		1
940	SMHX-940F	Name Plate	5 Ton	1
941	SMH-941A	Rivet	2.5 x 6	4
942	187728	Hand Chain*	Ø 5mm	1
943	121005	Load Chain* (5-Ton)	Ø 9mm	1

* Specify required chain length when ordering.

TEST CERTIFICATE

COMMODITY	Chain Hoist
MODEL	SMHX-
SERIAL NO.	
CAPACITY	ton
TEST LOAD	ton
LIFT	ft.
DATE OF INSPECTION	
JUDGEMENT	PASSED
INSPECTOR	

Record your purchase and installation information here

Purchased from: _____ Date: _____
Serial Number: _____ Model Number: _____
Stock Number: _____
Location Installed: _____
Date Installed: _____ Date in Service: _____



WMH Tool Group
2420 Vantage Drive
Elgin, Illinois 60123
Phone: 800-274-6848
www.wmhtoolgroup.com