

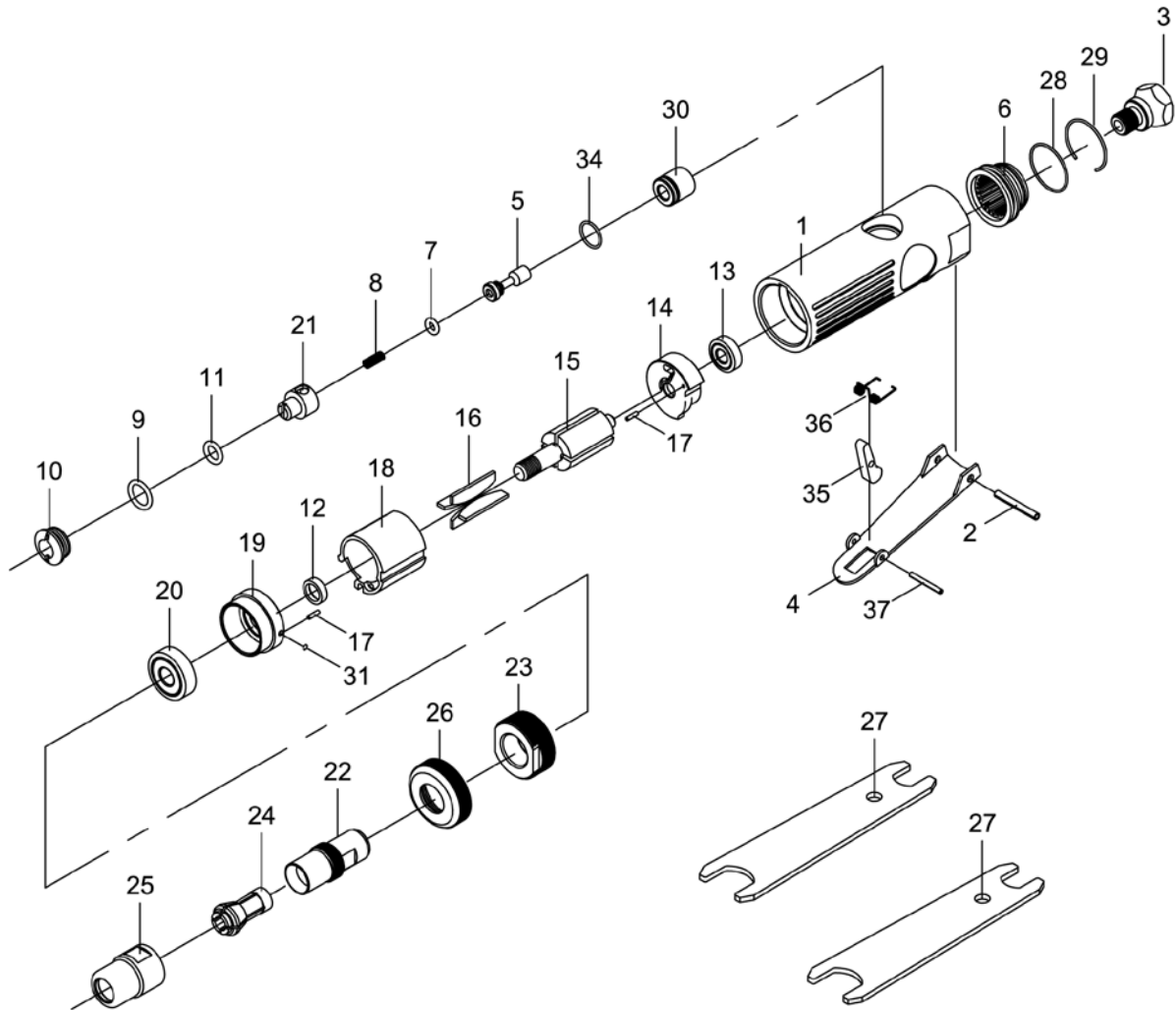

JSM-532 1/4-inch Die Grinder

(parts list on reverse side)



JET

427 New Sanford Road
LaVergne, Tennessee 37086
Ph.: 800-274-6848
www.jettools.com

Part No. M-JSM-532
Revision G3 06/2014
Copyright © 2014 JET

Parts List for JSM-532 Die Grinder

Index No.	Part No.	Description	Size	Qty
1	52201	Motor Housing		1
2	SM-30102	Spring Pin	Ø3 x 24L mm	1
3	52203	Air Inlet		1
4	53204	Throttle Lever		1
5	52205	Valve Stem		1
6	52206	Deflector		1
7	30107NPN	O-Ring	Ø3.8 x 1.9mm	1
8	52208	Spring		1
9	70109NPN	O-Ring	Ø9.8 x 1.9mm	1
10	52210	Valve Screw		1
11	40305	O-Ring	Ø6.5 x 2 mm	1
12	52212	Rotor Spacer		1
13	BB-696ZZ	Ball Bearing	696ZZ	1
14	52214	Rear End Plate		1
15	52215	Rotor		1
16	52216	Rotor Blade		4
17	30117NPN	Spring Pin	Ø1.5 x 6mm	2
18	52218	Cylinder		1
19	52219	Front End Plate		1
20	BB-608ZZ	Ball Bearing	608ZZ	1
21	52221	Controller		1
22	53222	Spindle		1
23	53223	Retainer		1
24	51224	Collet	1/4"	1
25	52225	Collet Nut		1
26	53226	Housing Cap		1
27	52227	Spanner		2
28	52235	O-Ring	Ø22.8 x 2mm	1
29	52229	Retaining Ring		1
30	52234	Bushing		1
31	SB-3/32	Steel Ball	3/32"	1
34	52236	O-Ring	Ø10.5 x 1mm	1
35	51540	Lever Bar		1
36	51541	Spring		1
37	51542	Spring Pin	Ø2 x 18L mm	1
	RPK-532	Repair Kit (Contains Index # 7, 8, 9, 11, 16, 28, 29)		

Specifications

Stock number	JSM-532
Collet size (in.)	1/4
Horsepower	1/4 HP
Free speed (RPM)	25,000
Air pressure (PSI)	90
Air consumption (CFM)	4
Air inlet (in.)	1/4 NPT
Air hose inside diameter (in.)	3/8
Vibration value (m/s ²)	0.9
Overall length (in.)	6
Noise level (dB)	91
Weight (Shipping/net)(lb)	1.1/0.8