

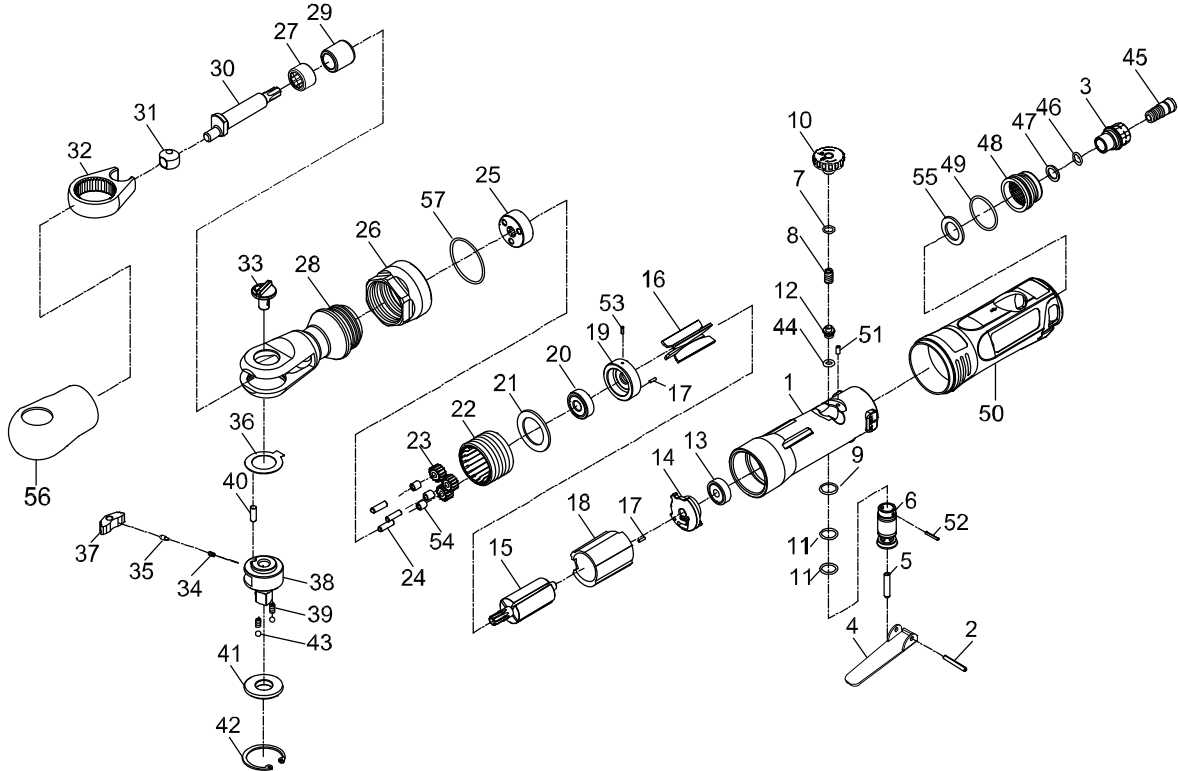

# JSM-3330

## 3/8" Air Ratchet Wrench

Stock No. JSM-3330



Index Part No	Description	Qty	Index Part No	Description	Qty
1	JSM3330-01 ..Housing.....	1	20	BB-608ZZ .....Ball Bearing (608ZZ).....	1
2	JSM3330-02 ..Spring Pin (Ø3x20L).....	1	21	SM-30121 .....Washer.....	1
3	JSM3330-03 ..Air Inlet.....	1	22	SM-30122 .....Thread Ring Gear.....	1
4	JSM3330-04 ..Throttle Lever.....	1	23	JSM3330-23 ..Idler Gear .....	3
5	JSM3330-05 ..Throttle Valve .....	1	24	SM-30124 .....Idler Gear Pin (4x13.8L) .....	3
6	JSM3330-06 ..Bushing.....	1	25	SM-30125 .....Idler Gear Plate .....	1
7	JSM3330-07 ..O-Ring (6.5x1.5).....	1	26	JSM3330-26 ..Clamp Nut .....	1
8	JSM3330-08 ..Spring .....	1	27	JSM3330-27 ..Needle Bearing .....	1
9	JSM3330-09 ..O-Ring (11.4x1.25).....	1	28	JSM3330-28 ..Ratchet Housing .....	1
10	JSM3330-10 ..Knob .....	1	29	SM-30129 .....Bushing .....	1
11	JSM3330-11 ..O-Ring (10.7x1.5).....	2	30	JSM3330-30 ..Crank Shaft .....	1
12	JSM3330-12 ..Throttle Valve .....	1	31	JSM3330-31 ..Drive Bushing.....	1
13	BB-696ZZ .....Ball Bearing (696ZZ) .....	1			
14	JSM3330-14 ..Rear End Plate.....	1			
15	SM-30115 .....Rotor.....	1			
16	SM-30116 .....Rotor Blade .....	4			
17	SM-30117 .....Pin (Ø1.5x6L).....	2			
18	50118 .....Cylinder.....	1			
19	JSM3330-19 ..Front End Plate .....	1			

*Parts List continued on back*

To order parts, call our service department at 800-274-6848 Monday through Friday (see our website for business hours). Having the Model Number and Serial Number will allow us to serve you quickly and accurately

**JET**  
 427 New Sanford Road  
 La Vergne, Tennessee 37086  
 Ph.: 800-274-6848  
 www.jettools.com

**Part No. M-JSM-3330**  
 Revision B1 07/2014

Copyright © 2014 JET, a Division of JPW Industries, Inc.

Index Part No	Description	Qty	Index Part No	Description	Qty	
32	JSM3330-32 .. Yoke .....	1	46	JSM3330-46 ..O-Ring (7.5x1.5).....	1	
33	JSM3330-33 ..Reverse Button .....	1	47	JSM3330-47 ..Washer.....	1	
34	JSM3330-34 .. Spring .....	1	48	JSM3330-48 ..Deflector.....	1	
35	JSM3330-35 ..Lock Pin .....	1	49	JSM3330-49 ..O-Ring (26.7x1.78).....	1	
36	SM-30136.....Washer .....	1	50	JSM3330-50 ..Grip.....	1	
37	SM-30137.....Ratchet Pawl.....	1	51	JSM3330-51 ..Spring Pin (Ø2.5x6L).....	1	
38	SM-30138.....Ratchet Anvil 3/8".....	1	52	JSM3330-52 ..Spring Pin (Ø2x12L).....	1	
39	SM-30139.....Spring .....	2	53	70117 .....	Spring Pin (Ø2x5L).....	1
40	SM-30140.....Pin (Ø4.5x12.7L).....	1	54	JSM3330-54 ..Bushing .....	3	
41	JSM3330-41 .. Thrust Washer 3/8".....	1	55	JSM3330-55 ..Damping Material .....	1	
42	SM-30142.....Retainer Ring (RTW-31.5)....	1	56	JSM3330-56 ..Rubber Cap.....	1	
43	SB-5/32 .....	Steel Ball (5/32") .....	2	57	JSM3330-57 ..O-Ring (29.4x3.1).....	1
44	JSM3330-44 ..O-Ring (3.8x1.9).....	1				
45	JSM3330-45 ..Fixed Shaft.....	1		..... RPK-3330 .....	Repair Kit	
					(includes #7,8,9,11,16,39,41, 42, 43,44,46,49,51,57)	
				..... RBK-3330 .....	Rebuild Kit	
					(includes #23,31,34,35,36,37)	

## Specifications for 3/8" Air Ratchet Wrench

Stock number .....	JSM-3330
Square Drive (in.) .....	3/8
Bolt Capacity (in.) .....	3/8
Anvil Retainer Type .....	Ball
Maximum Torque (ft.-lbs.) .....	50
Free Speed (RPM) .....	150
Air Consumption (CFM) .....	4
Air Inlet (NPT/in.) .....	1/4
Air Hose (ID/in.) .....	3/8
Vibration Value (m/s <sup>2</sup> ) .....	2.6
Noise Level (dB) .....	79
Overall Length (in.) .....	10
Weight (lbs.) .....	2-5/8

The above specifications were current at time of publication, but because of our policy of continuous improvement, JET reserves the right to change specifications at any time and without prior notice, without incurring obligations.