

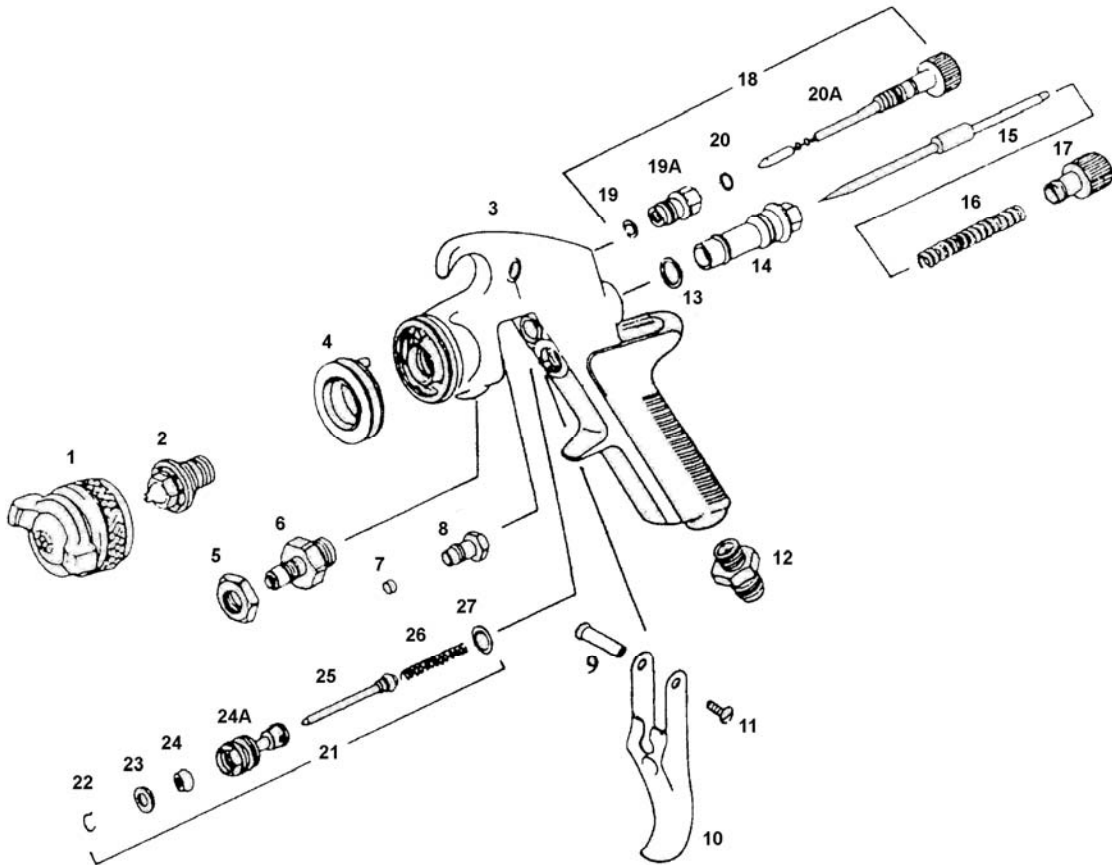

Parts List

JSG-1046 Spray Gun



Specifications

Stock Number.....	JSG-1046
Air Pressure (PSI).....	50-60
Air Consumption (CFM)	4-7
Air Inlet (NPT/In.).....	1/4
Air Hose Inside Diameter (in.).....	3/8
Cup Capacity (L).....	1
Fluid Nozzle Size (mm).....	2.3
Overall Length (in.)	7
Net Weight (lbs.).....	4

JET
 427 New Sanford Road
 LaVergne, Tennessee 37086
 Ph.: 800-274-6848
 www.jettools.com

Part No. M-JSG-1046
 Revision A1 06/2014
 Copyright © 2014 JET, a Division of JPW Industries, Inc.

Parts List For JSG-1046 Spray Gun

Index No.	Part No.	Description	Size	Qty
1	JSG1046-01	Air Nozzle		1
2	JSG1046-02	Fluid Nozzle		1
3	JSG1046-03	Body		1
4	JSG1046-04	Baffle		1
5	JSG1046-05	Lock Nut		1
6	JSG1046-06	Nipple		1
7	JSG1046-07	Packing		1
8	JSG1046-08	Packing Gland		1
9	JSG1046-09	Trigger Stud		1
10	JSG1046-10	Trigger		1
11	JSG1046-11	Screw		1
12	JSG1046-12	Inlet Connector		1
13	JSG1046-13	Gasket		1
14	JSG1046-14	Bushing		1
15	JSG1046-15	Fluid Needle		1
16	JSG1046-16	Spring		1
17	JSG1046-17	Adjusting Screw		1
18	JSG1046-18	Fan Adjustment Assembly (Index #19, 19A, 20, 20A)		1
19		Retaining Ring		1
19A		Bushing		1
20		O-Ring		1
20A		Side Port Stem Assembly		1
21	JSG1046-21	Air Valve Assembly (Index #22, 23, 24, 24A, 25, 26, 27)		1
22		Snap Ring		1
23		Washer		1
24		U Cup Seal		1
24A		Air Valve Bushing		1
25		Air Valve		1
26		Spring		1
27		Gasket		1
	RPK-JSG1046	Repair Kit (Contains Index #5, 13, 24, 26, 27)		1
	RBK-JSG1046	Rebuild Kit (Contains Index #15, 18, 22, 23, 25)		1

Note: Index #19, 19A, 20, 20A, 22, 23, 24, 24A, 25, 26, 27 not sold individually.