

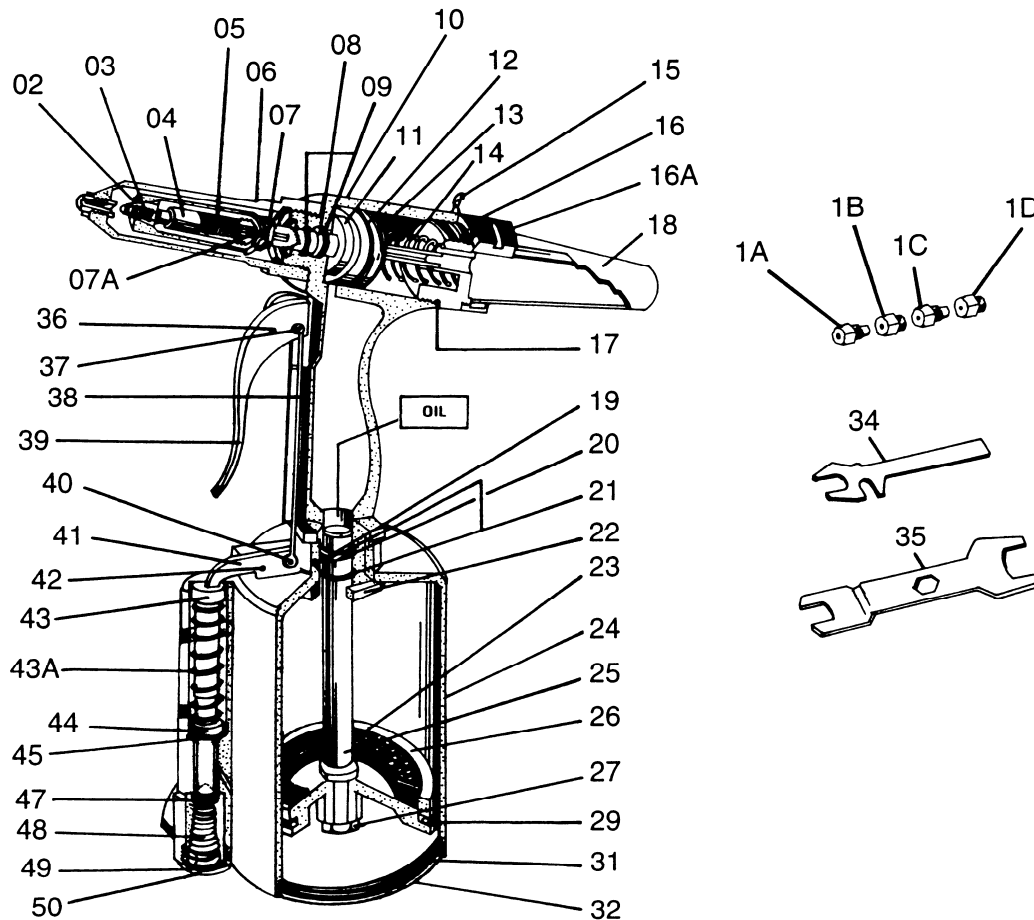

Operating Instructions and Parts List JSG-0810 Air Riveter



Adding Hydraulic Oil

1. Disconnect the tool from the air supply.
2. Hold the tool upside down.
3. Use the spanner wrench (35) to unscrew the cylinder cap (32).
4. Pull on the lock nut (27) with a pair of pliers to pull the air piston assembly (26) out of the air cylinder (24). Add 10 WT hydraulic oil to the cylinder neck until it flows over, approximately 10 drops of fluid.
5. Lightly lubricate the inside wall of the cylinder, and reinstall the air piston assembly (26).
6. Tighten the cylinder cap (32).

JET

427 New Sanford Road
LaVergne, Tennessee 37086
Ph.: 800-274-6848
www.jettools.com

Part No. M-JSG-0810

Revision A1 07/2014

Copyright © 2014 JET, a Division of JPW Industries, Inc.

JSG-0810 Air Riveter Parts List

Index No.	Part No.	Description	Size	Qty.
1A	706-1A	Nosepiece *	3/16"	1
1B	706-1B	Nosepiece *	5/32"	1
1C	706-1C	Nosepiece *	1/8"	1
1D	706-1D	Nosepiece *	3/32"	1
02	706-02	Jaw Case *		1
03	706-03	Jaw *		2
04	706-04	Jaw Pusher		1
05	706-05	Jaw Pusher Spring		1
06	706-06	Frame Head		1
07	706-07	Case Lock Nut	7/16"X20X4T	1
07A	706-07A	Case Washer Ring	7/16"	1
08	706-08	Back Up Ring	P12	1
09	706-09	Back Up O-ring *	P12	2
10	706-10	Frame		1
11	706-11	Oil Piston		1
12	706-12	Oil Piston O-ring *	P22A	1
13	706-13	Back-Up Ring	P22A	1
14	706-14	Return Spring		1
15	706-15	Hanging Clip		1
16	706-16	Frame Cup		1
16A	706-16A	Safety Cap Nut		1
17	706-17	Frame Clip O-ring *	27X2	1
18	706-18	Safety Cap		1
19	706-19	Set Screw Pin	4X32	1
20	706-20	Back Up Ring	P12	1
21	706-21	Back Up O-ring *	P12	2
22	706-22	Frame Lock Nut		1
23	706-23	Rubber Cushion		1
24	706-24	Air Cylinder		1
25	706-25	Air Piston Stem		1
26	706-26	Air Piston		1
27	706-27	Air Piston Lock Nut	5/16"X18UNC	1
29	706-29	Air Piston O-ring *	P60	1
31	706-31	Cylinder O-ring *	70X2.5	1
32	706-32	Cylinder Cap		1
34	706-34	Spanner Gauge		1
35	706-35	Spanner Wrench		1
36	706-36	Trigger Pin	3X18	1
37	706-37	Connector		1
38	706-38	Trigger Rod		1
39	706-39	Trigger		1
40	706-40	Connector		1
41	706-41	Trigger Lever		1
42	706-42	Lever Pin	3X22	1
43	706-43	Valve Pusher		1
43A	706-43A	Valve Pusher Spring		1
44	706-44	Valve Collar		1
45	706-45	Valve-O-ring	6.1X1.8	1
47	706-47	Valve		1
48	706-48	Valve Spring		1
49	706-49	Valve Cap O-ring	P14	1
50	706-50	Valve Cap		1
	RBK-0810	Rebuild Kit (incls 1A,1B, 1C, 1D, 02, 03, 09, 12, 17, 21, 29, 31).		