

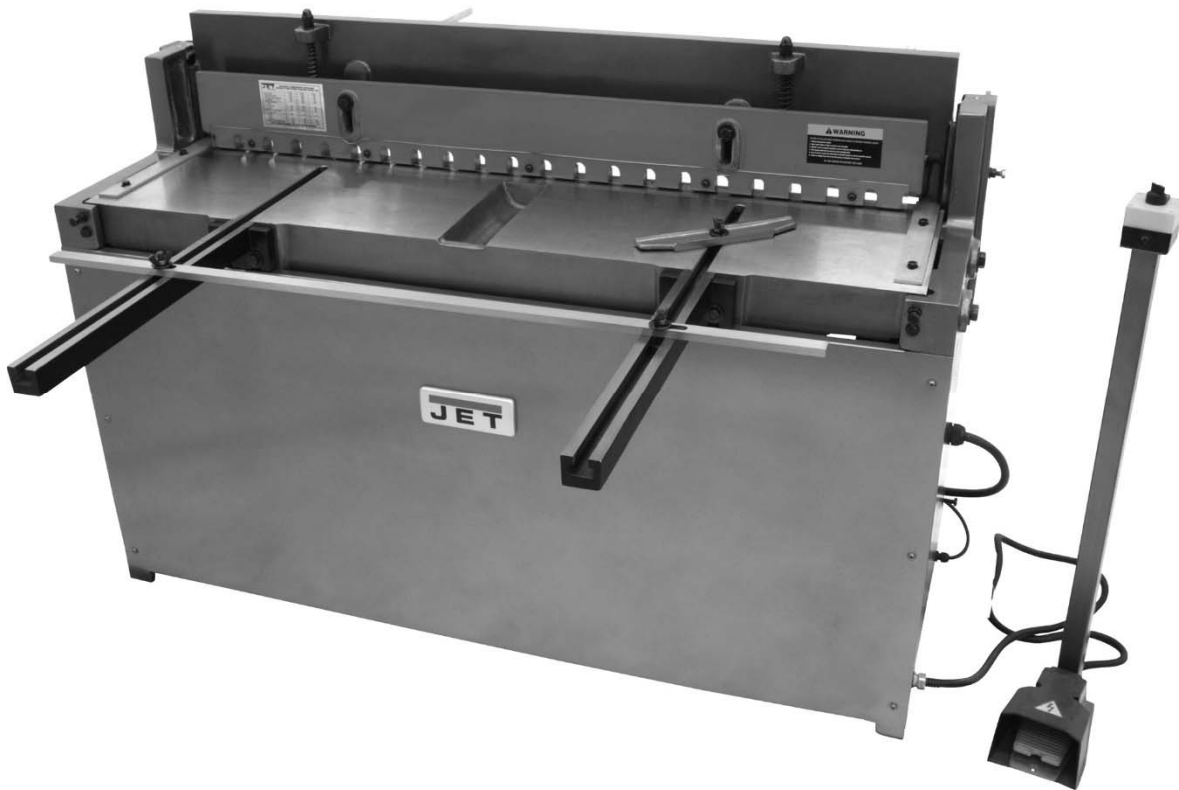

Operating Instructions and Parts Manual

16ga. x 52-inch Pneumatic Shear

Model PS-1652T



JET

427 New Sanford Road
LaVergne, Tennessee 37086
Ph.: 800-274-6848
www.jettools.com

Part No. M-756203
Revision C1 08/2018
Copyright © 2015 JET



1.0 IMPORTANT SAFETY INSTRUCTIONS

READ ALL INSTRUCTIONS BEFORE USING THIS MACHINE.

WARNING – To reduce risk of injury:

1. Read and understand the entire owner's manual before attempting assembly or operation.
2. Read and understand the warnings posted on the machine and in this manual. Failure to comply with all of these warnings may cause serious injury. Replace warning labels if they become obscured or removed.
3. This pneumatic shear is designed and intended for use by properly trained and experienced personnel only. If you are not familiar with the proper and safe operation of a shear, do not use until proper training and knowledge have been obtained.
4. Do not use this machine for other than its intended use. If used for other purposes, JET disclaims any real or implied warranty and holds itself harmless from any injury that may result from that use.
5. Always wear ANSI approved safety glasses/face shields while using this shear. *Everyday eyeglasses only have impact resistant lenses; they are not safety glasses.*
6. Do not wear loose clothing, gloves, neckties, rings, bracelets, or other jewelry which may get caught in moving parts. Wear protective hair covering to contain long hair. Non-slip footwear or anti-skid floor strips are recommended.
7. Do not operate this machine while tired or under the influence of drugs, alcohol or any medication.
8. Do not exceed the rated capacity of this shear; use hand tools for small or narrow parts. Do not attempt to shear hardened materials.
9. Sheet metal stock has sharp edges. To prevent cuts, use leather work gloves when handling.
10. Keep hands and fingers clear of the area in front and rear of the shear.
11. Do not place your hands between material being sheared and the shear table.
12. Keep safety guards in place at all times when the machine is in use. If removed for maintenance purposes, use extreme caution and replace the guards immediately after maintenance is complete.
13. Check damaged parts. Before further use of the machine, a guard or other part that is damaged should be carefully checked to determine that it will operate properly and perform its intended function. Check for alignment of moving parts, binding of moving parts, breakage of parts, mounting and any other conditions that may affect its operation. A guard or other part that is damaged should be properly repaired or replaced.
14. Provide for adequate space surrounding work area and non-glare, overhead lighting.
15. Keep the floor around the machine clean and free of scrap material, oil and grease.
16. Keep visitors a safe distance from the work area. **Keep children away.**
17. Make your workshop child proof with padlocks, master switches or by removing starter keys.
18. Give your work undivided attention. Looking around, carrying on a conversation and "horse-play" are careless acts that can result in serious injury.
19. Maintain a balanced stance at all times so that you do not fall or lean against moving parts. Do not overreach or use excessive force to perform any machine operation.
20. Use the right tool at the correct speed and feed rate. Do not force a tool or attachment to do a job for which it was not designed. The right tool will do the job better and more safely.
21. Use recommended accessories; improper accessories may be hazardous.
22. Maintain tools with care. Keep tools sharp and clean for the best and safest performance. Follow instructions for lubricating and changing accessories.
23. Do not stand on the machine. Serious injury could occur if the machine tips over.
24. Unplug or lock out power to the machine when not in use.

 **WARNING:** This product can expose you to chemicals including lead which is known to the State of California to cause cancer and birth defects or other reproductive harm. For more information go to <http://www.p65warnings.ca.gov>.

⚠ WARNING: Some dust, fumes and gases created by power sanding, sawing, grinding, drilling, welding and other construction activities contain chemicals known to the State of California to cause cancer and birth defects or other reproductive harm. Some examples of these chemicals are:

- lead from lead based paint
- crystalline silica from bricks, cement and other masonry products
- arsenic and chromium from chemically treated lumber

Your risk of exposure varies, depending on how often you do this type of work. To reduce your exposure to these chemicals, work in a well-ventilated area and work with approved safety equipment, such as dust masks that are specifically designed to filter out microscopic particles. For more information go to <http://www.p65warnings.ca.gov/> and <http://www.p65warnings.ca.gov/wood>.

Familiarize yourself with the following safety notices used in this manual.

⚠ CAUTION This means that if precautions are not heeded, it may result in minor injury and/or possible machine damage.

⚠ WARNING This means that if precautions are not heeded, it may result in serious or even fatal injury.

2.0 About this manual

This manual is provided by JET covering the safe operation and maintenance procedures for a JET Model PS-1652T Pneumatic Shear. This manual contains instructions on installation, safety precautions, general operating procedures, maintenance instructions and parts breakdown. Your machine has been designed and constructed to provide consistent, long-term operation if used in accordance with the instructions set forth in this document.

If there are questions or comments, please contact your local supplier or JET. JET can also be reached at our web site: www.jettools.com.

Retain this manual for future reference. If the machine transfers ownership, the manual should accompany it.

3.0 Warranty and Service

JET® warrants every product it sells against manufacturers' defects. If one of our tools needs service or repair, please contact Technical Service by calling 1-800-274-6846, 8AM to 5PM CST, Monday through Friday.

Warranty Period

The general warranty lasts for the time period specified in the literature included with your product or on the official JET branded website.

- JET products carry a limited warranty which varies in duration based upon the product. (See chart below)
- Accessories carry a limited warranty of one year from the date of receipt.
- Consumable items are defined as expendable parts or accessories expected to become inoperable within a reasonable amount of use and are covered by a 90 day limited warranty against manufacturer's defects.

Who is Covered

This warranty covers only the initial purchaser of the product from the date of delivery.

What is Covered

This warranty covers any defects in workmanship or materials subject to the limitations stated below. This warranty does not cover failures due directly or indirectly to misuse, abuse, negligence or accidents, normal wear-and-tear, improper repair, alterations or lack of maintenance. JET woodworking machinery is designed to be used with Wood. Use of these machines in the processing of metal, plastics, or other materials outside recommended guidelines may void the warranty. The exceptions are acrylics and other natural items that are made specifically for wood turning.

Warranty Limitations

Woodworking products with a Five Year Warranty that are used for commercial or industrial purposes default to a Two Year Warranty. Please contact Technical Service at 1-800-274-6846 for further clarification.

How to Get Technical Support

Please contact Technical Service by calling 1-800-274-6846. **Please note that you will be asked to provide proof of initial purchase when calling.** If a product requires further inspection, the Technical Service representative will explain and assist with any additional action needed. JET has Authorized Service Centers located throughout the United States. For the name of an Authorized Service Center in your area call 1-800-274-6846 or use the Service Center Locator on the JET website.

More Information

JET is constantly adding new products. For complete, up-to-date product information, check with your local distributor or visit the JET website.

How State Law Applies

This warranty gives you specific legal rights, subject to applicable state law.

Limitations on This Warranty

JET LIMITS ALL IMPLIED WARRANTIES TO THE PERIOD OF THE LIMITED WARRANTY FOR EACH PRODUCT. EXCEPT AS STATED HEREIN, ANY IMPLIED WARRANTIES OF MERCHANTABILITY AND FITNESS FOR A PARTICULAR PURPOSE ARE EXCLUDED. SOME STATES DO NOT ALLOW LIMITATIONS ON HOW LONG AN IMPLIED WARRANTY LASTS, SO THE ABOVE LIMITATION MAY NOT APPLY TO YOU.

JET SHALL IN NO EVENT BE LIABLE FOR DEATH, INJURIES TO PERSONS OR PROPERTY, OR FOR INCIDENTAL, CONTINGENT, SPECIAL, OR CONSEQUENTIAL DAMAGES ARISING FROM THE USE OF OUR PRODUCTS. SOME STATES DO NOT ALLOW THE EXCLUSION OR LIMITATION OF INCIDENTAL OR CONSEQUENTIAL DAMAGES, SO THE ABOVE LIMITATION OR EXCLUSION MAY NOT APPLY TO YOU.

JET sells through distributors only. The specifications listed in JET printed materials and on official JET website are given as general information and are not binding. JET reserves the right to effect at any time, without prior notice, those alterations to parts, fittings, and accessory equipment which they may deem necessary for any reason whatsoever. JET® branded products are not sold in Canada by JPW Industries, Inc.

Product Listing with Warranty Period

90 Days – Parts; Consumable items
1 Year – Motors; Machine Accessories
2 Year – Metalworking Machinery; Electric Hoists, Electric Hoist Accessories; Woodworking Machinery used for industrial or commercial purposes
5 Year – Woodworking Machinery
Limited Lifetime – JET Parallel clamps; VOLT Series Electric Hoists; Manual Hoists; Manual Hoist Accessories; Shop Tools; Warehouse & Dock products; Hand Tools; Air Tools

NOTE: JET is a division of JPW Industries, Inc. References in this document to JET also apply to JPW Industries, Inc., or any of its successors in interest to the JET brand.

4.0 Table of Contents

Section	Page
1.0 IMPORTANT SAFETY INSTRUCTIONS	2
2.0 About this manual	3
3.0 Warranty and Service.....	4
4.0 Table of Contents.....	5
5.0 General Features and Terminology	6
6.0 Specifications	7
7.0 Set-Up and Assembly	8
7.1 Hole center dimensions.....	8
7.2 Unpacking	8
7.3 Stop assemblies.....	8
7.4 Electrical connections.....	9
8.0 Adjustments	10
8.1 Table and blades.....	10
8.2 Air regulator.....	10
8.3 Rear stop micro adjust	10
8.4 Hold-down tension.....	10
8.5 Gibs	10
9.0 Maintenance.....	11
10.0 Troubleshooting	11
11.0 Replacement Parts.....	11
11.1.1 PS-1652T Assembly – Exploded View.....	12
11.1.2 PS-1652T Assembly – Parts List.....	13
12.0 Electrical connections	16

5.0 General Features and Terminology

Numbers refer to corresponding index numbers in parts list.

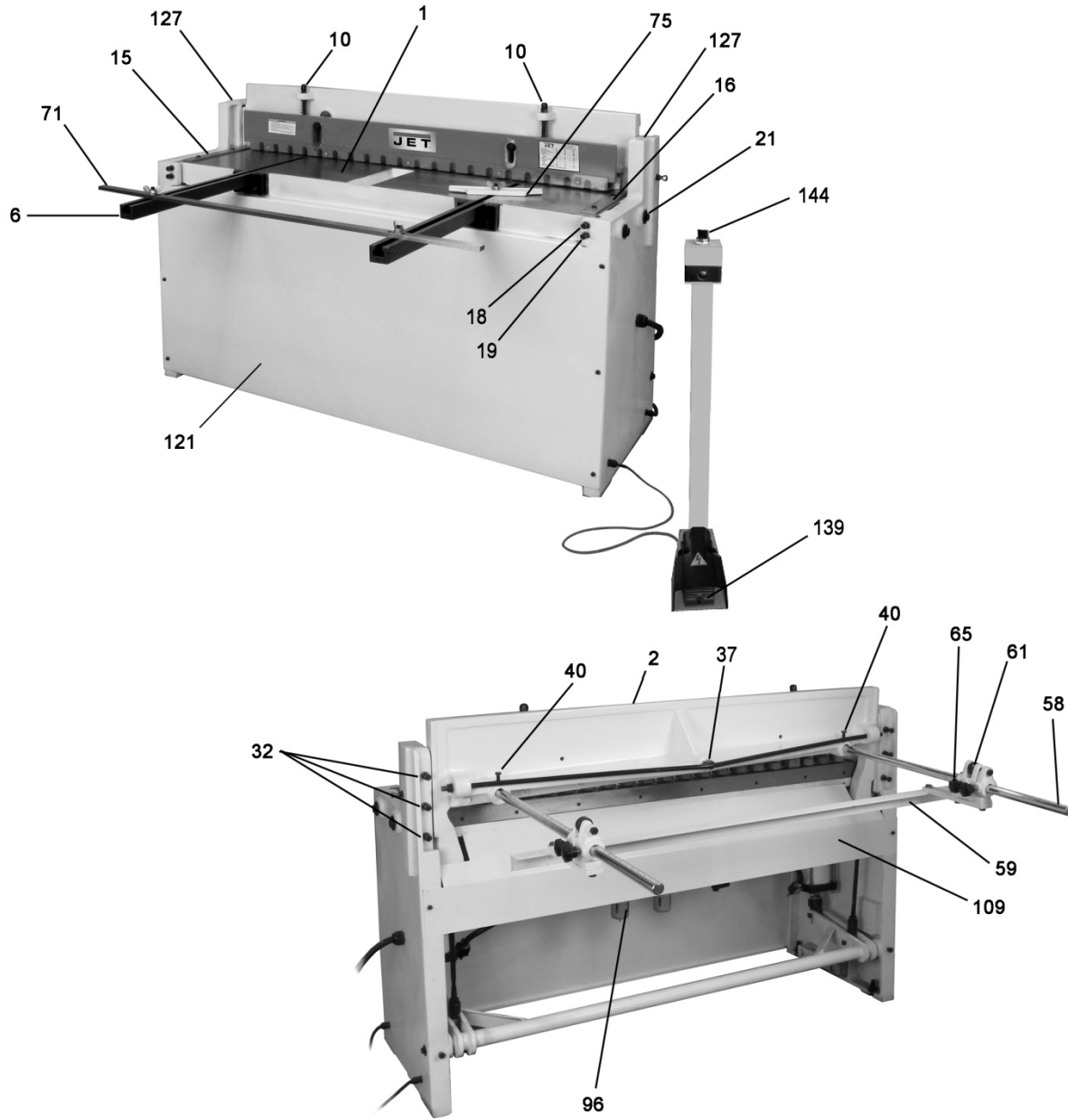

Figure 1

1	Table	59	Rear Stop
2	Cutter Bar	61	Adjusting Block
3	Hold Down	65	Adjusting Block knobs
6	Front Arm Extension	71	Front Stop
10	Spring Tension Adjusting Nuts	75	Bevel Gauge
15	Left Scale	96	Filter Regulator Assembly
16	Right Scale	109	Rear Cover
18/19	Table Adjustment Screws	119	Foot Pedal
21	Table Bolts	121	Front Cover
32	Gib Screws	127	Oil Fitting
37	Tie-Rod Adjustment Screw	139	Foot Pedal
40	Screws for securing Scale Rods	144	On/Off Switch

6.0 Specifications

Model Number PS-1652T
Stock Number 756203

Materials:

Frame cast iron
Table cast iron
Blades ground hardened steel
Hold-down cast iron
Front Stop steel
Rear Stop cast iron & steel

Capacities:

Material thickness capacity – mild steel 16 gauge
Material thickness capacity – aluminum and copper alloys 12 to 14 gauge
Shearing length capacity 52" (1320mm)
Back stop capacity 29-1/2" (750mm)
Front stop capacity 35-1/4" (895mm)

Motor and Electrical:

Foot control 110V, 60Hz
On/Off switch rotary
Power cable length 7 ft. (213cm)
Foot pedal cable length 5 ft. (152cm)
Noise emission 40-60 dB

Air System:

Air hose length 7 ft. (213cm)
Operating/maximum air pressure (psi) 85-100 (0.6-0.7 Mpa)
Air consumption (approx. cfm) 25.4
Air consumption per stroke (approx. cfm) 1.4
Strokes per minute 40 without load; 20 with load
Recommended air hose diameter 1/2"
Air hose inlet (NPT) 3/8"

Dimensions:

Shipping dimensions (LxWxH) 30" x 67" x 46" (760 x 1702 x 1168mm)
Overall dimensions, fully assembled (LxWxH) 73" x 60" x 41" (1855 x 1525 x 1045mm)
Footprint (LxW) 21" x 60" (533 x 1525mm)

Weights:

Net weight, approximate 1312 lbs. (550 kg)
Shipping weight, approximate 1344 lbs. (610 kg)

The specifications in this manual were current at time of publication, but because of our policy of continuous improvement, JET reserves the right to change specifications at any time and without prior notice, without incurring obligations.



Read and understand the entire contents of this manual before attempting set-up or operation! Failure to comply may cause serious injury.

7.0 Set-Up and Assembly

7.1 Hole center dimensions

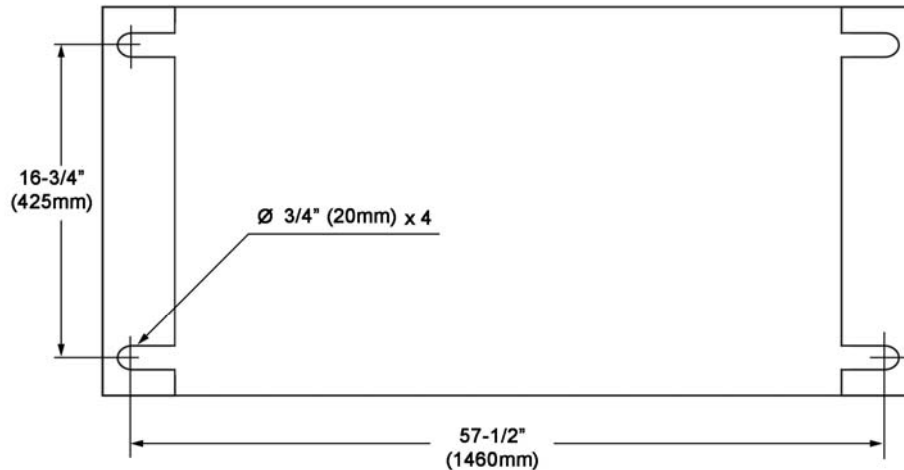

Figure 2

7.2 Unpacking

Open shipping container and check for shipping damage. Report any damage immediately to your distributor and shipping agent. Do not discard any shipping material until the Shear is assembled and running properly.

Compare the contents of your container with the following list to make sure all parts are intact. Missing parts, if any, should be reported to your distributor. Read the instruction manual thoroughly for assembly, maintenance and safety instructions.

Contents of the Shipping Container

- 1 Pneumatic Shear with Foot Pedal
 - 2 Front Arm Extensions
 - 1 Front Stop, with hardware
 - 1 Rear Stop, with hardware
 - 2 Scale Rods
 - 2 Adjusting Block Assemblies
 - 1 Bevel Gauge, with hardware
 - 1 Instructions and Parts Manual
 - 1 Warranty Card
1. Remove the crating material from around the machine.
 2. Clean the protectant from all exposed metal surfaces with a mild solvent or kerosene, and a soft rag. Do not use lacquer thinner, paint thinner, or gasoline, as these may damage painted surfaces.
 3. Coat all machined surfaces with a light coat of oil to inhibit rust.
 4. Remove the bolts holding the machine to the skid.

5. Place straps below the table (you may have to remove front cover), and use properly rated lifting equipment to move the machine to a level foundation. Machine location must allow access to all sides. Use shims at floor if needed.

Assembly Note: Prior to shipment, the pneumatic shear is adjusted at the factory for proper alignments and operation. If the machine does not operate properly or the stand does not sit squarely on the floor, proceed to *Set-Up Adjustments*.

6. When the machine sits evenly, secure it to the floor using proper fasteners. Refer to Figure 2.

7.3 Stop assemblies

Refer to Figure 1. (Numbers in parentheses refer to corresponding part in exploded view.)

1. Attach the two *front arm extensions* (6) to the bed with four *hex cap screws* (7) and four *washers* (76). Level arm extension surfaces with the table before tightening.
2. Attach *front stop* (71) to front arm extensions with T-screws (72) and wing nuts (74).
3. Attach *rear stop* (59) to the *adjusting block assemblies* (61) with six hex cap screws (68) and six flat washers (77).
4. Insert a *scale rod* (58) through each adjusting block assembly and into cutter bar. The scales must face up.
5. Secure the *scale rods* in the cutter bar by tightening the two hex cap screws (40). Tighten the rods in the adjusting blocks with the four knobs (65).

7.4 Electrical connections

⚠WARNING Electrical connections must be made by a qualified electrician in compliance with all relevant codes. This machine must be properly grounded to help prevent electrical shock and possible fatal injury.

7.4.1 Grounding instructions

This machine must be grounded. In the event of a malfunction or breakdown, grounding provides a path of least resistance for electric current to reduce the risk of electric shock.

The Pneumatic Shear is equipped with a 15 amp cord and plug set, with a grounding prong. The plug must be plugged into a matching outlet that is properly installed and grounded in accordance with all local codes and ordinances. Do not modify the plug provided – if it will not fit the outlet, have the proper outlet installed by a qualified electrician.

Improper connection of the equipment-grounding conductor can result in a risk of electric shock. The conductor with insulation having an outer surface that is green with or without yellow stripes, is the equipment-grounding conductor. If repair or replacement of the electric cord or plug is necessary, do not connect the equipment-grounding conductor to a live terminal.

Check with a qualified electrician or service personnel if the grounding instructions are not completely understood, or if in doubt as to whether the tool is properly grounded. Repair or replace a damaged or worn cord immediately.

Use only 3-wire extension cords that have 3-prong grounding plugs and 3-pole receptacles that accept the machine's plug. As received from the factory, your shear is ready to operate at 115-volt operation. This shear, when wired for 115 volt, is intended for use on a circuit that has an outlet that looks like the one illustrated in Figure 3. The tool has a grounding plug that looks like the plug illustrated in Figure 3.

Make sure your power supply matches the information on the specification plate of the machine.

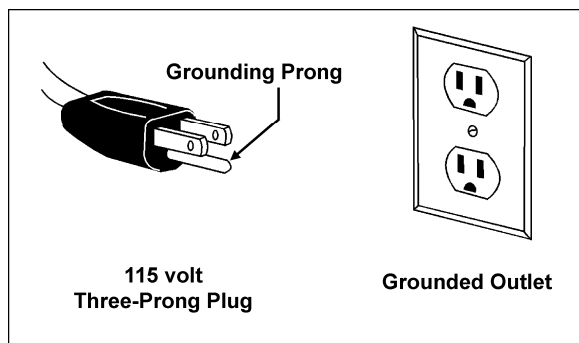

Figure 3

7.4.2 Extension cords

The use of an extension cord is not recommended. Try to place shop equipment within reach of the power source. If an extension cord becomes necessary, make sure the cord rating is suitable for the amperage listed on the machine's motor plate. An undersized cord will cause a drop in line voltage resulting in loss of power and overheating.

Use the chart in Figure 17 as a general guide in choosing the correct size cord. If in doubt, use the next heavier gauge. The smaller the gauge number, the heavier the cord.

Recommended Gauges (AWG) of Extension Cords

Amps	Extension Cord Length *					
	25 feet	50 feet	75 feet	100 feet	150 feet	200 feet
< 5	16	16	16	14	12	12
5 to 8	16	16	14	12	10	NR
8 to 12	14	14	12	10	NR	NR
12 to 15	12	12	10	10	NR	NR
15 to 20	10	10	10	NR	NR	NR
21 to 30	10	NR	NR	NR	NR	NR

*based on limiting the line voltage drop to 5V at 150% of the rated amperes.

NR: Not Recommended.

Table 1

8.0 Adjustments

8.1 Table and blades

1. If the table requires adjustment, loosen four bolts (21); do not remove. Loosen nuts on the adjusting screws (18,19). The bed must rest squarely on the right and left hand side panels at all four corners while screws are loose. Shim legs at floor if necessary. Tighten hardware.
2. Use set screw (18) and hex cap screw (19), to adjust the lower blade toward or away from the upper blade. The distance between the upper and lower blades should be 0.002-0.005". **Do not** let the blades overlap.
3. Connect machine to electrical supply, and adjust the air pressure until the gauge reads approximately 90 psi.
4. Place a heavy sheet of paper (-0.005"/0.13mm) in the cutting position, along the entire length of the bed.
5. Turn switch to ON and press the foot pedal.
6. If the shear does not cut the paper, move the lower blade toward the upper blade.
7. If the shear cuts the paper on the ends, but not the center, turn the tie-rod adjusting screw (37), clockwise until the paper is cut the entire length.
8. If the shear cuts the paper in the center, but not the ends, turn the tie-rod adjusting screw (37) counter-clockwise until the paper is cut the entire length.
9. Make sure the scales (15,16) on top of the table are square to the blade, and also show the correct distance from the blade.
10. Make test cuts to verify that the scales are correct.

8.2 Air regulator

Refer to Figure 4.

1. Connect air source to quick connector.
2. Set the desired air pressure between 90-120 PSI using the pressure dial (A) on the filter/regulator (clockwise to increase). Lock the setting by pushing down the pressure dial. Pull up on the dial to readjust a setting.
3. Adjust oil flow using dial (B) at top of *lubricator*. A setting of 2 drips per minute is sufficient for regular operation.

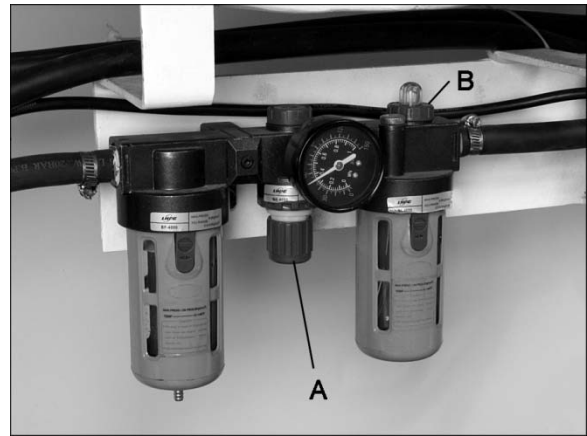

Figure 4

8.3 Rear stop micro adjust

Refer to Figure 5.

The knurled dial on the adjusting block can be used for micro positioning of the rear stop. Tighten knob (A) and make knob (B) snug. Rotate dial (C) until pointer (D) is at desired position. Tighten knob (B).

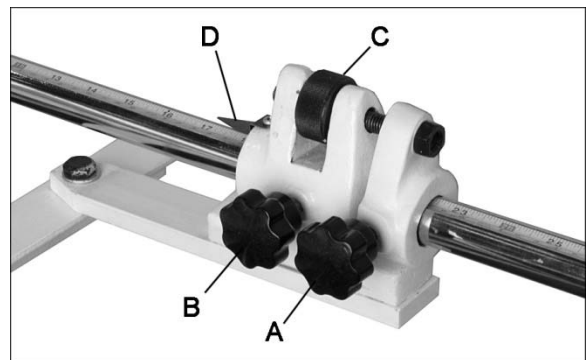

Figure 5

8.4 Hold-down tension

The spring return can be adjusted on the hold down (3) by tightening the lower hex nuts (10).

8.5 Gibs

There are three hex cap screws (32) that can be adjusted for play in each shim (31). Loosen the jam nuts (33) to turn the screws. Adjust for smooth travel. Retighten jam nuts.

9.0 Maintenance

CAUTION Use care when working with or around the knives.

The 2-way upper knife can be removed and flipped 180°, for a new edge before having to be sharpened.

Periodically insert oil through the two oil fittings (127) atop the side panels. Use ISO VG32 or equivalent.

Wipe the knives lightly with oil.

Lubricate all pivot points on the machine daily.

Empty the condensation cups on the air regulator as needed.

10.0 Troubleshooting

Trouble	Probable Cause	Remedy
Blades will not cut material.	Incorrect gap between blades.	Increase gap for thicker gauge metals.
	Material exceeds machine capacity.	Stay within capacity.
	Blades are dull.	Replace or sharpen blades.
Unsatisfactory cuts.	Blades dull.	Replace or sharpen blades.
	Incorrect gap between blades.	Correct gap.
	Loose gibs.	Remove backlash from gibs.
Cuts not square.	Inadequate hold-down pressure.	Adjust pressure of hold-down.
	Blade gap unequal.	Adjust gap equally across length of blade.
	Uneven guide contact.	Place work against guide consistently.
	Blade is bowed.	Adjust blade bow at the tie-rod.

11.0 Replacement Parts

Replacement parts are listed on the following pages. To order parts or reach our service department, call 1-800-274-6848 Monday through Friday, 8:00 a.m. to 5:00 p.m. CST. Having the Model Number and Serial Number of your machine available when you call will allow us to serve you quickly and accurately.

Some parts are shown for reference only, and may not be available individually.

Non-proprietary parts, such as fasteners, can usually be found at local hardware stores, or may be ordered from JET.

11.1.1 PS-1652T Assembly – Exploded View

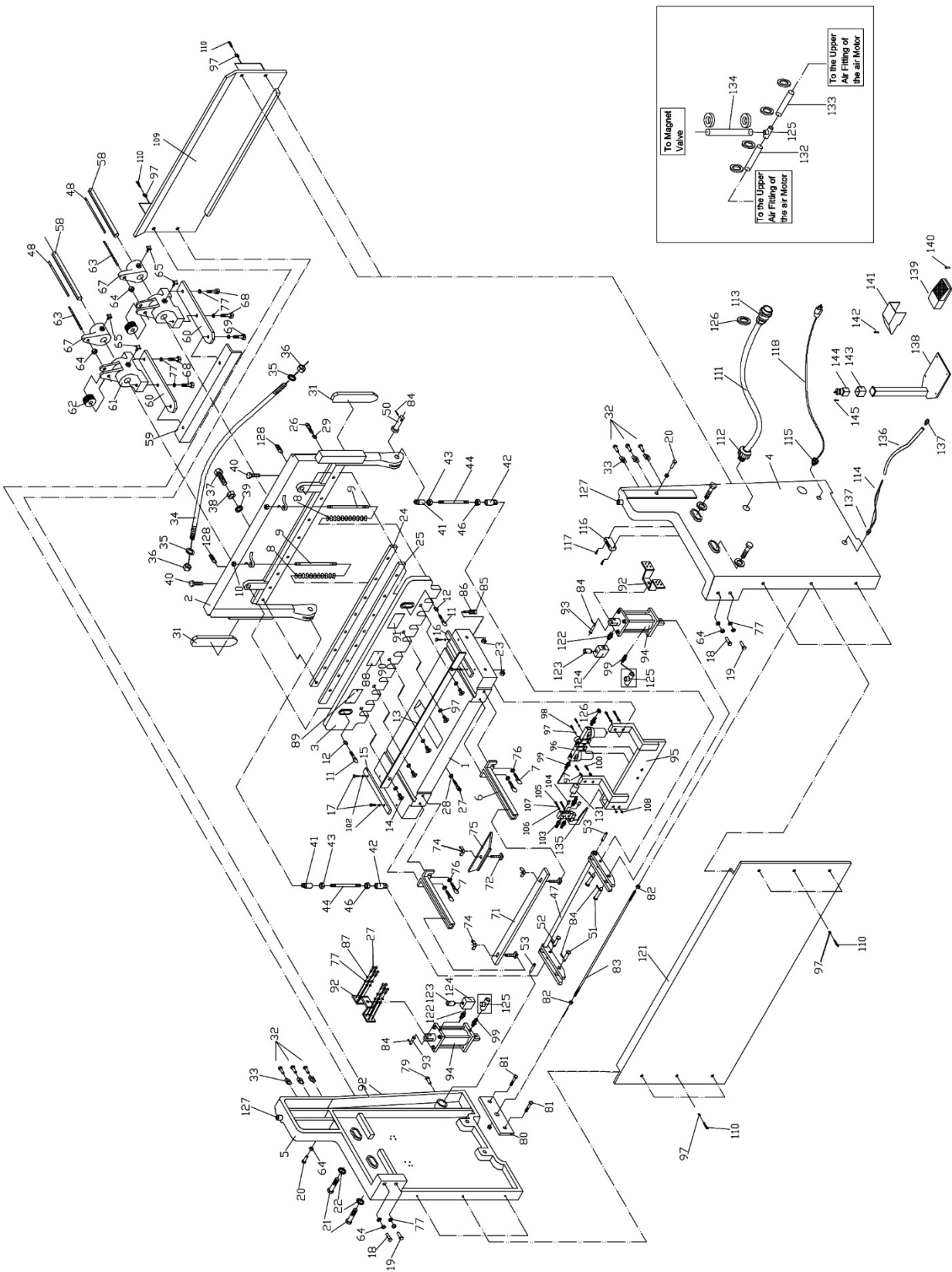

11.1.2 PS-1652T Assembly – Parts List

Index No.	Part No.	Description	Size	Qty
1	PS1652T-1G	Table		1
2	PS1652T-2G	Cutter Bar		1
3	PS1652T-3	Hold Down		1
4	PS1652T-4G	R.H. Side Panel		1
5	PS1652T-5G	L.H. Side Panel		1
6	PS1652T-6	Front Arm Extension		2
7	FS1636N-7	Hex Cap Screw	M12x45	4
8	PS1652T-8	Spring	3.5d x 18.5D x 180mm	2
9	PS1652T-9	Stud		2
10	FS1636N-10	Nylon Lock Hex Nut	M12	2
11	FS1636N-11	Hex Cap Screw	M12x80	2
12	FS1636N-12	Washer		2
13	PS1652T-13	Finger Guard		1
14	FS1636N-14	Phillips Pan Head Machine Screw	M6x12	5
15	PS1652T-15	Table Scale (L.H.)		1
16	PS1652T-16	Table Scale (R.H.)		1
17	FS1636N-17	Hex Cap Screw	M8x25	4
18	TS-2210451	Hex Cap Screw	M10x45	2
19	TS-1491101	Hex Cap Screw	M10x60	18
20	PS1652T-20	Hex Cap Screw	M10x50	2
21	PS1652T-21	Hex Cap Screw	M16x120	4
22	FS1636N-22	Washer		4
23	PS1652T-23	Nut	M16	4
24	PS1652T-24	Upper Knife		1
25	PS1652T-25	Lower Knife		1
26	FS1636N-27	Cap Screw	M10x45	9
27	PS1652T-27	Cap Screw	M10x50	24
28	FS1636N-28	Washer		9
29	FS1636N-29	Washer	10mm	17
31	PS1652T-31	Gib		2
32	TS-1505071	Socket Head Cap Screw	M10x45	6
33	FS1636N-33	Nut	M10	6
34	FS1636N-34	Rod		1
35	TS-155009	Plain Washer	14mm	2
36	PS1652T-36	Nut	M14	2
37	PS1652T-37	Screw	M16x70	1
38	FS1636N-38	Nut	M16	1
39	FS1636N-39	Washer	16mm	1
40	FS1636N-40	Hex Cap Screw	M10x35	2
41	PS1652T-41	Swivel		2
42	PS1652T-42	Swivel		2
43	FS1636N-46	Hex Nut (Right Hand Thread)	M16	2
44	PS1652T-44	Stud		2
46	PS1652T-46	Hex Nut (Left Hand Thread)	M16	2
47	PS1652T-47G	Cylinder Link Bar Assembly		1
48	PS1652T-48	Scale		2
49	FS1636N-49	Cross Head Pan Screw	M4x8	2
50	PS1652T-50	Pin	Ø12 x 85mm	2
51	PS1652T-51	Pin	Ø16 x 65mm	2
52	PS1652T-52	Pin	Ø12 x 65mm	4
53	PS1652T-53	Brake Pin		2
58	PS1652T-58	Scale Rod		2
59	PS1652T-59G	Rear Stop		1
60	PS1652T-60G	Extension Bar		2
61	PS1652T-61	Adjusting Block		2
62	PS1652T-62	Adjusting Dial		2
63	FS1636N-63	Adjusting Screw		2
64	FS1636N-64	Hex Nut	M10	4
65	PS1652T-65	Knob		4
67	PS1652T-66G	Adjusting Bracket		2

Index No.	Part No.	Description	Size	Qty
68	TS-1491031	Hex Cap Screw	M10x25	4
69	TS-1491021	Hex Cap Screw	M10x20	2
71	PS1652T-71	Front Stop		1
72	FS1636N-72	"T" Screw		3
74	TS-2321121	Wing Nut	M12	3
75	PS1652T-75	Bevel Gauge		1
76	FS1636N-76	Washer	12mm	4
77	FS1636N-77	Plain Washer	10mm	27
79	TS-1505071	Socket Head Cap Screw	M10x45	2
80	PS1652T-80	Plate		2
81	TS-1492021	Hex Cap Screw	M12x30	4
82	TS-2310201	Hex Nut	M20	4
83	PS1652T-83	Connection Bar	Ø20x1480mm	1
84	PS1652E-84	Cotter Pin	Ø4x30mm	8
85	PS1652E-85	Socket Head Cap Screw	M8x45	8
86	PS1652E-86	Hex Nut	M8	8
87	TS-2361101	Helical Spring Lock Washer	10mm	16
88	PS1652E-88	Rivet	Ø2x6mm	4
89	PS1652E-W	Warning Label		1
90	PS1652E-J	JET Plaque		1
91	PS1652E-S	Specification Label		1
92	PS1652T-92	Bracket		2
93	PS1652T-93	Shaft	Ø16x65mm	2
94	PS1652T-94	Air Motor Assembly		2
95	PS1652T-95	Bracket		1
96	PS1652E-96	Air Regulator Assembly	BC3000	1
97	TS-1550041	Plain Washer	6mm	17
98	TS-1503051	Socket Head Cap Screw	M6x20	2
99	PS1652E-99	Air Fitting	PT3/8"	15
100	TS-1504041	Socket Head Cap Screw	M8x20	4
102	TS-1550061	Plain Washer	8mm	8
103	PS1652E-103	Magnetic Valve	4V310-10-AC110V	1
104	PS1652E-104	Muffler	PT1/4"	2
105	PS1652T-105	Pan Head Machine Screw	M4x40	2
106	TS-1550021	Plain Washer	4mm	2
107	TS-2361041	Helical Spring Lock Washer	4mm	2
108	TS-1540021	Hex Nut	M4	2
109	PS1652T-109G	Rear Cover		1
110	TS-1503031	Socket Head Cap Screw	M6x12	14
111	PS1652T-111	Air Hose	1/2" x 700psi x 2m	1
112	PS1652E-112	Air Hose Holder	M30x1.5	1
113	PS1652E-113	Quick Fitting	Ø10mm	1
114	PS1652E-114	Cable	18AWGx3C,3m	1
115	PS1652E-115	Plastic Cable Holder	M16x1.5	1
116	PS1652T-116	Wiring Block	TB-1504	1
117	TS-1532052	Phillips Pan Head Machine Screw	M4x15	2
118	PS1652E-118	Power Cable with Plug	16AWG, 4M	1
121	PS1652T-121G	Front Cover		1
122	PS1652E-122	Air Fitting		2
123	PS1652E-123	Muffler	PT3/8"	2
124	PS1652E-124	Air Exhaust Valve	QE-03	2
125	PS1652E-125	3-Way Connection	PT3/8"	2
126	PS1652E-126	Holding Ring	Ø16-25mm	16
127	PS1652E-127	Oil Fitting	Ø10mm	2
128	PS1652T-128	Set Screw	M12x25	2
129	TS-1501041	Socket Head Cap Screw	M4x12	3
130	PS1652E-130	Rubber Grommet	Ø15	1
131	PS1652E-131	Air Hose	1/2" x 700psi x 0.12m	1
132	PS1652E-132	Air Hose	1/2" x 700psi x 1m	2
133	PS1652E-133	Air Hose	1/2" x 700psi x 0.5m	2
134	PS1652E-134	Air Hose	1/2" x 700psi x 0.6m	2
135	PS1652E-135	Cable	18AWGx3C,1.2m	1

Index No.	Part No.	Description	Size	Qty
136	PS1652T-136	Cable, Foot Pedal	Ø 18x2mm	1
137	PS1652T-137	Strain Relief	M20x1.5	4
138	PS1652T-138	Post (s/n 11120022 and higher)		1
139	PS1652T-119	Foot Control Pedal	SFMS-1	1
140	TS-1533052	Phillips Pan Head Machine Screw	M5x16	4
141	PS1652T-120	Foot Pedal Guard	SFMS-1	1
142	5712561	Phillips Pan Head Machine Screw	M5x8	4
143	PS1652T-143	Switch Box (s/n 11120022 and higher)	BX1-22	1
144	PS1652T-144	Select Switch (s/n 11120022 and higher)	SGB2-BD25 2NO	1
145	TS-2284082	Phillips Pan Head Machine Screw	M4x8	4
	LM000164	ID Label, PS-1652T (not shown)		1
	JET-203	JET Logo (not shown)	203 x 84mm	1

NOTE: Non-proprietary fasteners (part numbers beginning with TS-) are standard sizes, and can usually be found at local tool stores.

12.0 Electrical connections

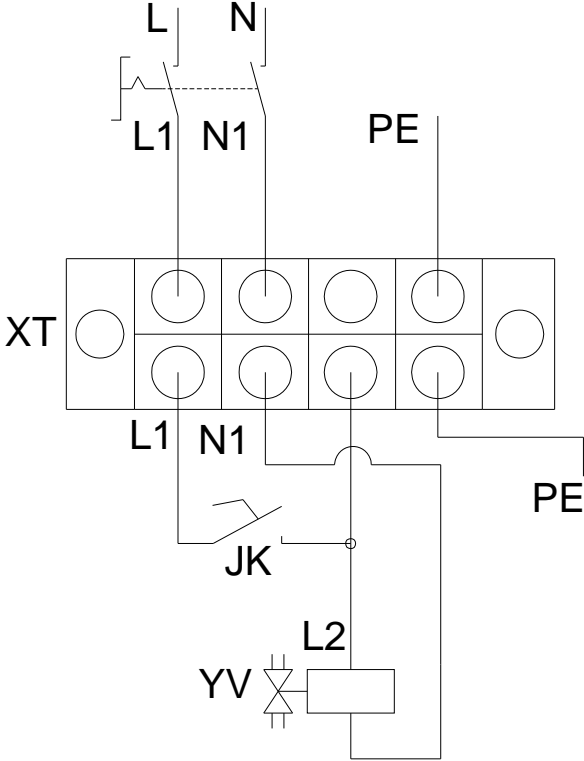

427 New Sanford Road
LaVergne, Tennessee 37086
Phone: 800-274-6848
www.jettools.com