



Operating Instructions and Parts Manual JWS-22CS Spindle Shaper



JET
427 New Sanford Road
LaVergne, Tennessee 37086
Ph.: 800-274-6848
www.jettools.com

Part No. M-708320
Revision G4 02/2019
Copyright © 2014 JET

Warranty and Service

JET warrants every product it sells against manufacturers' defects. If one of our tools needs service or repair, please contact Technical Service by calling 1-800-274-6846, 8AM to 5PM CST, Monday through Friday.

Warranty Period

The general warranty lasts for the time period specified in the literature included with your product or on the official JET branded website.

- JET products carry a limited warranty which varies in duration based upon the product. (See chart below)
- Accessories carry a limited warranty of one year from the date of receipt.
- Consumable items are defined as expendable parts or accessories expected to become inoperable within a reasonable amount of use and are covered by a 90 day limited warranty against manufacturer's defects.

Who is Covered

This warranty covers only the initial purchaser of the product from the date of delivery.

What is Covered

This warranty covers any defects in workmanship or materials subject to the limitations stated below. This warranty does not cover failures due directly or indirectly to misuse, abuse, negligence or accidents, normal wear-and-tear, improper repair, alterations or lack of maintenance. JET woodworking machinery is designed to be used with Wood. Use of these machines in the processing of metal, plastics, or other materials may void the warranty. The exceptions are acrylics and other natural items that are made specifically for wood turning.

Warranty Limitations

Woodworking products with a Five Year Warranty that are used for commercial or industrial purposes default to a Two Year Warranty. Please contact Technical Service at 1-800-274-6846 for further clarification.

How to Get Technical Support

Please contact Technical Service by calling 1-800-274-6846. **Please note that you will be asked to provide proof of initial purchase when calling.** If a product requires further inspection, the Technical Service representative will explain and assist with any additional action needed. JET has Authorized Service Centers located throughout the United States. For the name of an Authorized Service Center in your area call 1-800-274-6846 or use the Service Center Locator on the JET website.

More Information

JET is constantly adding new products. For complete, up-to-date product information, check with your local distributor or visit the JET website.

How State Law Applies

This warranty gives you specific legal rights, subject to applicable state law.

Limitations on This Warranty

JET LIMITS ALL IMPLIED WARRANTIES TO THE PERIOD OF THE LIMITED WARRANTY FOR EACH PRODUCT. EXCEPT AS STATED HEREIN, ANY IMPLIED WARRANTIES OF MERCHANTABILITY AND FITNESS FOR A PARTICULAR PURPOSE ARE EXCLUDED. SOME STATES DO NOT ALLOW LIMITATIONS ON HOW LONG AN IMPLIED WARRANTY LASTS, SO THE ABOVE LIMITATION MAY NOT APPLY TO YOU.

JET SHALL IN NO EVENT BE LIABLE FOR DEATH, INJURIES TO PERSONS OR PROPERTY, OR FOR INCIDENTAL, CONTINGENT, SPECIAL, OR CONSEQUENTIAL DAMAGES ARISING FROM THE USE OF OUR PRODUCTS. SOME STATES DO NOT ALLOW THE EXCLUSION OR LIMITATION OF INCIDENTAL OR CONSEQUENTIAL DAMAGES, SO THE ABOVE LIMITATION OR EXCLUSION MAY NOT APPLY TO YOU.

JET sells through distributors only. The specifications listed in JET printed materials and on official JET website are given as general information and are not binding. JET reserves the right to effect at any time, without prior notice, those alterations to parts, fittings, and accessory equipment which they may deem necessary for any reason whatsoever. JET® branded products are not sold in Canada by JPW Industries, Inc.

Product Listing with Warranty Period

90 Days – Parts; Consumable items; Light-Duty Air Tools
1 Year – Motors; Machine Accessories; Heavy-Duty Air Tools; Pro-Duty Air Tools
2 Year – Metalworking Machinery; Electric Hoists, Electric Hoist Accessories; Woodworking Machinery used for industrial or commercial purposes
5 Year – Woodworking Machinery
Limited Lifetime – JET Parallel clamps; VOLT Series Electric Hoists; Manual Hoists; Manual Hoist Accessories; Shop Tools; Warehouse & Dock products; Hand Tools

NOTE: JET is a division of JPW Industries, Inc. References in this document to JET also apply to JPW Industries, Inc., or any of its successors in interest to the JET brand.

Table of Contents

- Warranty and Service.....2
- Table of Contents.....3
- Warning.....4
- Electrical Connections.....6
- Introduction7
- Specifications7
- Unpacking and Cleanup.....8
- Adjustments9
 - Arbor Removal and Installation9
 - Collet Installation10
 - Fence Adjustments.....10
 - Table Ring Removal and Installation.....10
- Operation11
 - Spindle Control.....11
 - Using the Fence as a Guide.....11
 - Shaping with Collars and Starting Pin11
 - Collar Positioning12
 - Starting Pin.....12
 - Lubrication.....13
- Replacement Parts.....15
 - Table and Fence Breakdown16
 - Cabinet Breakdown17
 - Parts List18
 - Electrical Schematic21
 - Electrical Schematic for the Forward/Reverse Switch.....22

Warnings

Wear eye protection.

Be sure keyed washer is directly under the spindle nut and the spindle nut is tight.

Feed the workpiece against the rotation of the cutter.

Do not use awkward hand positions.

Keep fingers away from the revolving cutter. Use fixtures when necessary.

Use the overhead guard when the adjustable fence is not in place.

- **KEEP GUARDS IN PLACE** and in working order.
- **REMOVE ADJUSTING KEYS AND WRENCHES.** Form a habit of checking to see that keys and adjusting wrenches are removed from the machine before turning it on.
- **KEEP THE WORK AREA CLEAN.** Cluttered areas and benches invite accidents.
- **DON'T USE IN A DANGEROUS ENVIRONMENT.** Don't use power tools in damp or wet locations, or expose them to rain. Keep work area well lighted.
- **KEEP CHILDREN AWAY.** All visitors should be kept a safe distance from the work area.
- **MAKE THE WORKSHOP KIDPROOF** with padlocks, master swatches, or by removing starter keys.
- **DON'T FORCE THE MACHINE.** It will do the job better and safer at the rate for which it was designed.
- **USE THE RIGHT MACHINE.** Don't force a machine or attachment to do a job for which it was not designed.
- **USE THE PROPER EXTENSION CORD.** Make sure your extension cord is in good condition. When using an extension cord, be sure to use one heavy enough to carry the current your machine will draw. An undersized cord will cause a drop in the line voltage resulting in power loss and overheating. The table below shows the correct size to use depending on cord length and nameplate ampere rating. If in doubt, use the next heavier gauge. The smaller the gauge, the heavier the cord.

Volts	Total Length of Cord in Feet			
	120V	25	50	100
240V	50	100	200	300
	AWG			
	16	16	14	12

- **WEAR PROPER APPAREL.** Do not wear loose clothing, gloves, neckties, rings, bracelets, or other jewelry which may get caught in moving parts. Non-slip footwear is recommended. Wear protective hair covering to contain long hair.
- **ALWAYS USE SAFETY GLASSES.** Also use face or dust masks if the cutting operation is dusty. Everyday eyeglasses only have impact resistant lenses; they are not safety glasses.
- **SECURE WORK.** Use clamps or a vise to hold work when practical. It's safer than using your hand and it frees both hands to operate the tool.
- **DON'T OVERREACH.** Keep proper footing and balance at all times.

- **MAINTAIN TOOLS WITH CARE.** Keep tools sharp and clean for best and safest performance. Follow instructions for lubricating and changing accessories.
- **ALWAYS DISCONNECT THE MACHINE FROM THE POWER SOURCE BEFORE SERVICING.**
- **REDUCE THE RISK OF UNINTENTIONAL STARTING.** Make sure the switch is in the off position before plugging in.
- **USE RECOMMENDED ACCESSORIES.** Consult the operator's manual for recommended accessories. The use of improper accessories may cause risk of injury to persons.
- **NEVER STAND ON A MACHINE.** Serious injury could occur if the machine tips or if the blade/cutter is unintentionally contacted.
- **CHECK DAMAGED PARTS.** Before further use of the machine, a guard or other part that is damaged should be carefully checked to determine that it will operate properly and perform its intended function - check for alignment of moving parts, binding of moving parts, breakage of parts, mounting, and any other conditions that may affect its operation. A guard or other part that is damaged should be properly repaired or replaced.
- **DIRECTION OF FEED.** Feed work into the cutter against the direction of rotation of the cutter only.
- **NEVER LEAVE THE MACHINE RUNNING UNATTENDED. TURN POWER OFF.** Don't leave the machine until it comes to a complete stop.
- **DO NOT OPERATE** this machine while tired or under the influence of drugs, alcohol or any medication.

 **WARNING:** This product can expose you to chemicals including lead which is known to the State of California to cause cancer and birth defects or other reproductive harm. For more information go to <http://www.p65warnings.ca.gov>.

 **WARNING:** Drilling, sawing, sanding or machining wood products generates wood dust and other substances known to the State of California to cause cancer. Avoid inhaling dust generated from wood products or use a dust mask or other safeguards for personal protection.

Wood products emit chemicals known to the State of California to cause birth defects or other reproductive harm. For more information go to <http://www.p65warnings.ca.gov/wood>.

Familiarize yourself with the following safety notices used in this manual:



This means that if precautions are not heeded, it may result in minor injury and/or possible machine damage.



This means that if precautions are not heeded, it may result in serious or even fatal injury.

- - SAVE THESE INSTRUCTIONS - -

Electrical Connections

⚠ WARNING Electrical connections must be made by a qualified electrician in compliance with all relevant codes. This machine must be properly grounded to help prevent electrical shock and possible fatal injury.

115 Volt Operation

As received from the factory, your shaper is ready to run at 115 volt operation. This shaper, when wired for 115 volt, is intended for use on a circuit that has an outlet and a plug that looks the one illustrated in Figure A. A temporary adapter, which looks like the adapter as illustrated in Figure B, may be used to connect this plug to a two-pole receptacle, as shown in Figure B if a properly grounded outlet is not available. The temporary adapter should only be used until a properly grounded outlet can be installed by a qualified electrician. **This adapter is not applicable in Canada.** The green colored rigid ear, lug, or tab, extending from the adapter, must be connected to a permanent ground such as a properly grounded outlet box, as shown in Figure B.

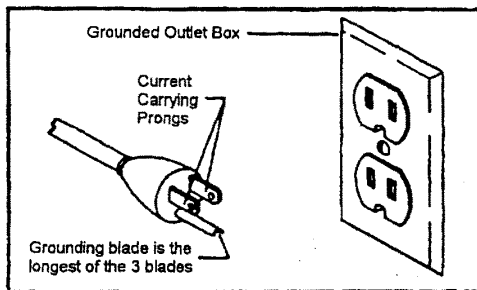

Figure A

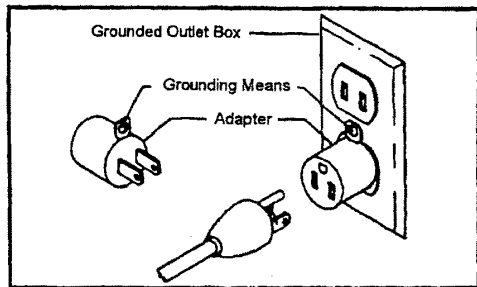

Figure B

Important: In all cases (115 or 230 volts), make certain the receptacle in question is properly grounded. If you are not sure, have a registered electrician check the receptacle.

230 Volt Operation

If 230V, single phase operation is desired, the following instructions must be followed:

1. Disconnect the machine from the power source.
2. This shaper is supplied with six motor leads that are connected for 115V operation, as shown in Figure C. Reconnect these six motor leads for 230V operation, as shown in Figure D.
3. The 115V attachment plug, supplied with the shaper, must be replaced with a UL/CSA listed plug suitable for 230V operation. This plug is illustrated in Fig. E. Contact your local Authorized JET Service Center or qualified electrician for proper procedures to install the plug. The shaper must comply with all local and national codes after the 230 volt plug is installed.
4. The shaper with a 230 volt plug should only be connected to an outlet having the same configuration as illustrated by the grounded outlet box in Figure E. No adapter is available or should be used with the 230 volt plug.

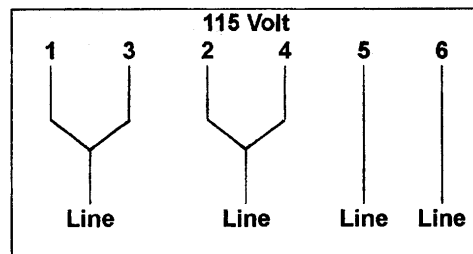

Figure C

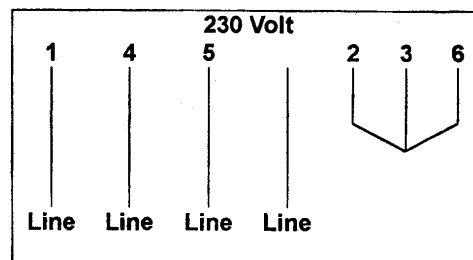

Figure D

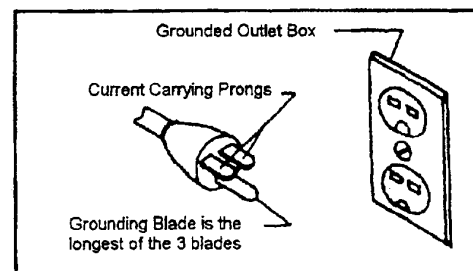

Figure E

Introduction

The JET JWS-22CS woodworking shaper you have purchased is a high quality machine tool that will give you years of superior service. You will get maximum performance and enjoyment from your new shaper if you will take a few moments now to review the entire manual before beginning assembly and operation. Become familiar with the details of operation.

The JET JWS-22CS, as well as all JET products, are backed by a nationwide network of authorized distributors and/or service centers. Please contact your nearest distributor should you require parts or service. Parts are also available directly from JET by calling 1-800-274-6848.

Now that you have purchased a shaper, it is a good time to consider a dust collection system. See your local JET distributor for the complete line of dust collectors and the full line of JET Dust Collector Hoses and Accessories. Customize your installation and obtain maximum performance with JET dust hoods, hoses, clamps, fittings, and blast gates.

Specifications

Model Number.....	JWS-22CS
Stock Number	708320
Cutterhead Speed(reversible)(RPM).....	7,000 & 9,000 RPM
Table Size (in.)	18-1/8 x 22-1/4
Table Slot (in.).....	3/4 x 3/8 T-slot
Table Opening Diameter (in.).....	5-1/4
Insert Opening Diameter (in.).....	1-5/8 and 3-1/4
Fence Size (2) (in.).....	10 x 3-1/8
Spindle Capacity (in.)	1/2 and 3/4
Router Bit Collet Capacity (in.).....	1/4 and 1/2
Under Nut Capacity (in.).....	1/2" Spindle: 2-1/2 ; 3/4" Spindle: 2-15/16
Spindle Travel (in.)	1-7/16
Table Height (in.).....	33-1/2
Overall Dimensions (in.).....	22-1/4 W x 25-1/2 D x 38-1/2 H
Dust Chute Diameter (in.)	4
Motor	TEFC, 1 1/2 HP, 1Ph, 115/230V (prewired 115V), 12/6 A, 60Hz
Net Weight (approx.)	192 lbs.
Shipping Weight (approx.).....	210 lbs.

The above specifications were current at the time this manual was published, but because of our policy of continuous improvement, JET reserves the right to change specifications at any time and without prior notice, without incurring obligations.

Unpacking and Cleanup

1. Finish removing all contents from the shipping container. Do not discard any shipping material until the shaper is set up and running.
1. Inspect contents for shipping damage and report any damage or missing parts to your distributor.
2. Clean all protected parts with kerosene. Do not use gasoline, paint thinner, or any cellulose-based solvent. These will damage painted surfaces and melt plastic.

Tools Required for Assembly

10mm Wrench
14mm Wrench

Contents of the Shipping Container

- 1 Shaper

Accessory Package

- 1 Dust Chute
- 1 Miter Gauge
- 1 Switch Lock Bracket
- 1 3/4" Spindle Assembly
- 1 1/4" Collet w/Nut
- 1 1/2" Collet w/Nut
- 1 Collet Nut
- 1 Spanner Wrench
- 1 8mm Hex Wrench
- 1 6mm Hex Wrench
- 1 3mm Hex Wrench

Dust Chute Assembly

1. Install dust chute to the fence body with two 1/4" x 1/2" hex cap bolts.

Adjustments

Arbor Removal and Installation

⚠WARNING All adjustments to the machine must be made with the power off and unplugged from the power source. Failure to comply may result in serious injury.

⚠WARNING The safety shield has been removed for illustration purposes only! Never operate the shaper without the safety shield. Failure to comply may result in serious injury.

The arbor is mounted to the main spindle with a draw bar and a nut. Use the following procedure to remove the arbor. Reverse the steps to install the arbor.

1. **Disconnect the machine from the power source.**
3. Raise the spindle fully by turning handwheel clockwise.
4. Open the door by pulling out the latch (A, Fig. 1). Open the door, and release the latch.
5. Pull the spindle locking mandrel (A, Fig. 2) out, and turn to lock the main spindle.
6. Loosen the draw bar nut (B, Fig. 2) with a 14mm box wrench or adjustable wrench and remove the nut (A, Fig. 3).
7. Loosen the hex nut (A, Fig. 4) with the arbor wrench (B, Fig. 3).
8. Loosen and remove the spindle (C, Fig. 3).
9. Remove the nut (A, Fig. 4) and draw bar (D, Fig. 3) from the spindle.
10. Pull the spindle locking mandrel out and turn to release the main spindle.
11. Close the door.



Figure 1

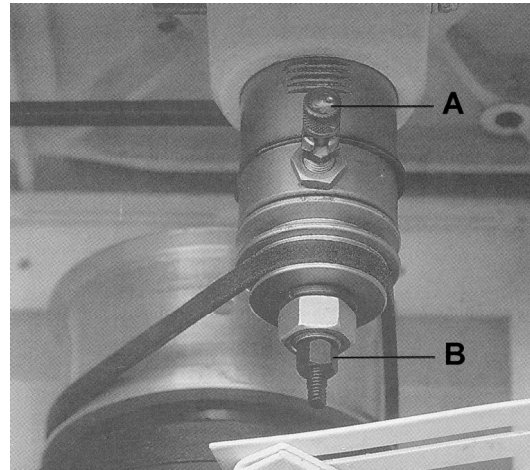

Figure 2

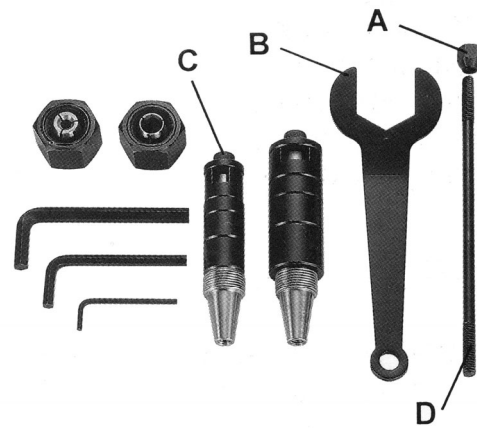

Figure 3

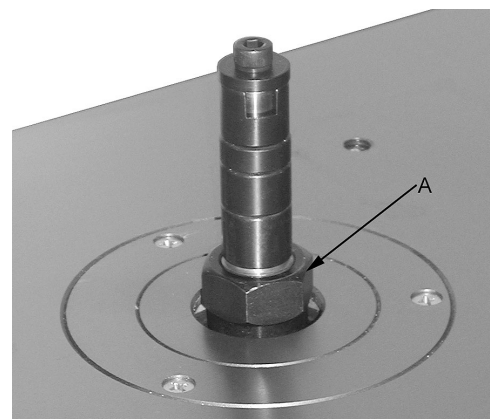

Figure 4

Collet Installation

1. **Disconnect machine from the power source.**
2. To set up the shaper for collet use, remove the arbor and clean the spindle taper (Fig. 5)
3. Raise the spindle fully by turning handwheel clockwise.
4. Pull the spindle locking mandrel out (A, Fig. 2) and turn to lock the main spindle.
5. Screw the collet assembly onto the spindle threads (Fig. 6).
6. Insert a router bit into the collet.
7. Tighten the collet nut with the arbor wrench.
8. Pull the spindle locking mandrel out and turn to release the main spindle



Figure 5

Fence Adjustments

1. Adjust fence halves by loosening lock knob (A, Fig. 7), turn knurled knob (B, Fig. 7) to adjust fence in or out, and tighten lock knob.
2. Adjust spindle guard height by loosening wing nut (C, Fig. 7), sliding guard up or down to desired height, and then tightening wing nut.
3. Adjust spindle guard depth by loosening two lock knobs (D, Fig. 7), moving spindle guard to desired position, and then tightening two lock knobs.
4. Hold down clamps can be adjusted for height by loosening hex socket cap screws (E, Fig. 7), adjusting the hold down clamps to the desired height, and tightening the hex socket cap screws.



Figure 6

Table Ring Removal and Installation

To remove the table ring(s):

1. Remove any collet or spindle assembly in the spindle.
2. Lower the spindle assembly completely.
3. Loosen and remove the three 1/4" x 5/8" cross point screws from the ring.
4. Lift ring.
5. Install the rings back into the table using the "witness" line (alignment indicator line) on the table and the table rings.

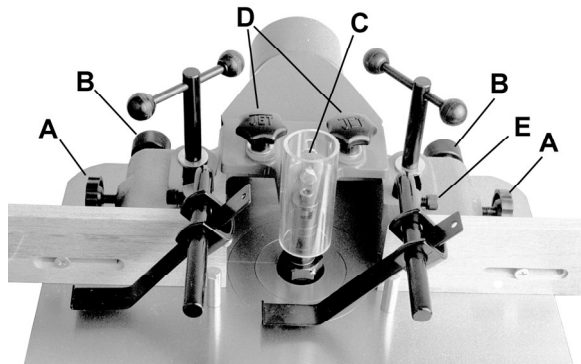

Figure 7

Operation

Spindle Control

To raise or lower spindle:

1. Loosen spindle lock handle counter clockwise (A, Fig. 8). The handle is spring-loaded; by pulling out you can adjust the positioning.
2. Raise or lower spindle to desired height by turning handwheel (B, Fig. 8).
3. Tighten spindle lock handle clockwise.

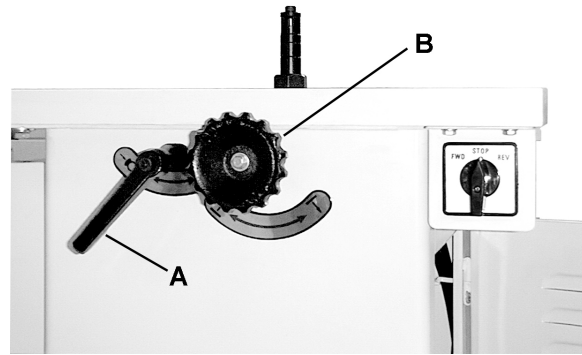

Figure 8

Using the Fence as a Guide

Shaping with the fence is the safest and most satisfactory method of working. This method should always be used when work permits. Almost all straight work can be used with the fence.

1. For most work, where a portion of the edge of the work is not touched by the cutter, both the front and rear fences are in a straight line, as shown in Figure 9.
2. When the shaping operation removes the entire edge of the work (i.e. jointing or making a full bead), the shaped edge will not be supported by the rear fence when both fences are in line as shown in Figure 10. In this case, the work piece should be advanced to the position shown in Figure 10 and stopped.
3. The rear fence should be advanced to contact the work as shown in Figure 11. The rear fence will then be in line with the cutting circle.

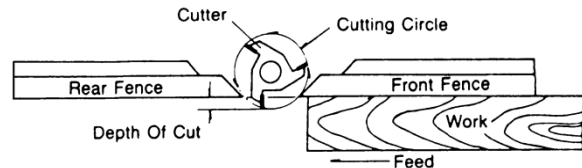

Figure 9

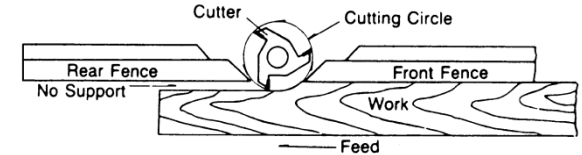

Figure 10

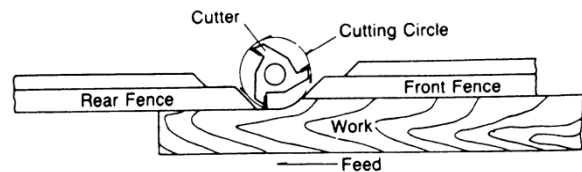

Figure 11

Shaping with Collars and Starting Pin

Follow these rules when shaping with collars and starting pin for safest operation and best results:

1. Collars must be smooth and free from all gum or other substances.
2. The edge of the work must be smooth. Any irregularity in the surface which rides against the collar will be duplicated on the shaped surface.
3. A portion of the work's edge must remain untouched by the cutter so that the collar will have sufficient bearing surface. See Figure 12 for an example of insufficient bearing surface. Figure 13 illustrates sufficient bearing surface.

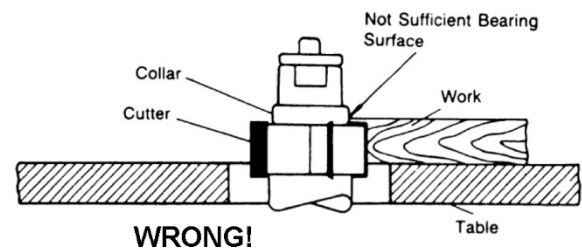

Figure 12

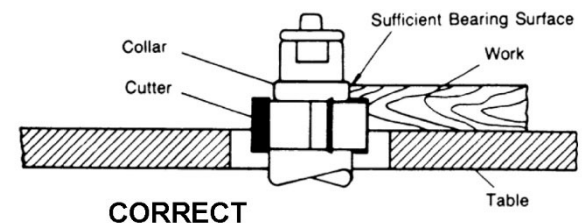

Figure 13

4. The work must be fairly heavy in proportion to the cut being made. See Figure 14. Under no circumstances should a small workpiece be shaped against the collars as shown in Figure 15.

Collar Positioning

Collars may be positioned above, below, or between two cutters:

1. When using the collar below the cutter, Figure 16, the progress of the cut can be observed at all times. A disadvantage of this method is any accidental lifting of the work will gouge the wood and ruin the workpiece.

2. Using the collar above the cutter, Figure 17, offers the advantage of the cut not being affected by slight variations in the stock's thickness. However, the cut is not visible during the operation. Another advantage is accidental lifting of the work piece will not gouge the work piece. Simply correct the mistake by repeating the operation.

3. The collar between cutters method, shown in Figure 18, has both the advantages and disadvantages of the first two methods. This method is used primarily where both edges of the work are to be shaped.

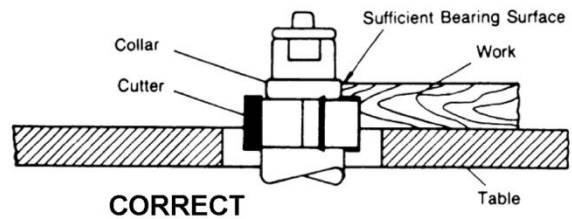

Figure 14

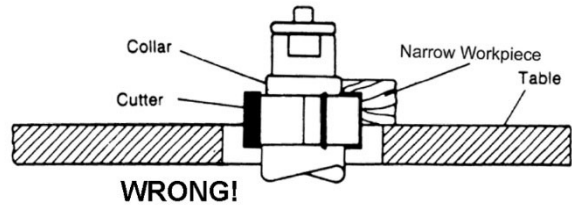

Figure 15

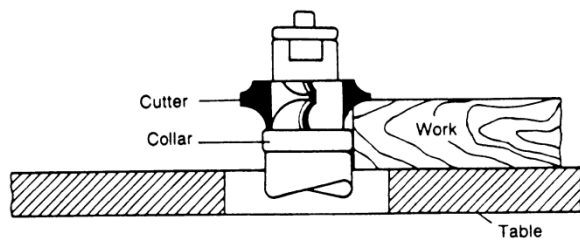

Figure 16

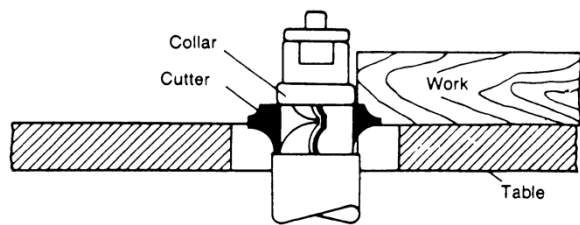

Figure 17

Starting Pin

⚠ WARNING Using the starting pin should only be attempted by advanced users! If you have never used this method before, it is recommended you get training from a qualified person who is knowledgeable in starting pin shaping!

Failure to comply may cause serious injury!

The starting pin is placed in one of the threaded holes in the table:

1. Work should be placed in the first position using the guide pin as support, as shown in Figure 19. Then swing the work into the cutter as shown in the second position. The work will now be supported by the collar and starting pin.

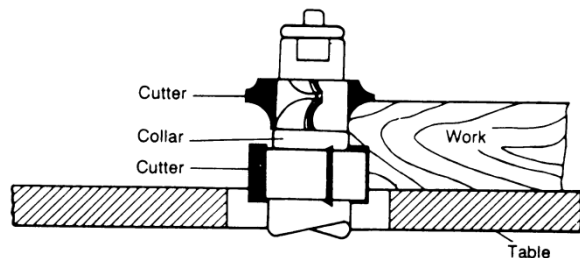

Figure 18

2. After the cut has been started, the work is swung free of the starting pin and rides only against the collar as shown in the third position in Figure 20. Always feed against the action of the cutter.

Lubrication

To insure easy movement when raising and lowering spindle, occasionally apply a drop of light oil on outside of spindle cartridge.

Spindle cartridge bearings are pre-lubricated and sealed. They need no further care.

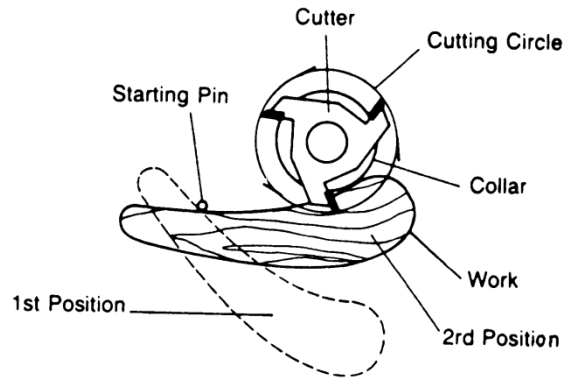

Figure 19

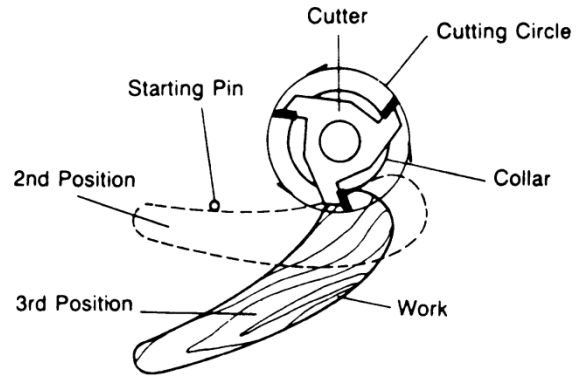

Figure 20

Troubleshooting

Trouble	Probable Cause	Remedy
Shaper will not start.	Cord unplugged from the power source.	Plug in power cord.
	Fuse blown, or circuit breaker tripped.	Replace fuse, or reset circuit breaker.
	Cord damaged.	Replace cord.
	Reversing switch is in the OFF position.	Turn switch to forward or reverse.
	Overload tripped.	Reset overload by depressing red stop button.
Overload kicks out frequently.	Extension cord or wiring inadequate size.	Replace cord or wiring with proper gauge wiring.
	Feeding stock too fast.	Reduce stock feed rate.
	Cutter head is dull.	Use only sharp cutters.
Cutter does not come up to full speed.	Shop wire gauge is too small.	Replace cord or wiring with proper gauge wire.
	Extension cord too light or too long.	Replace with adequate size cord.
	Power source is not adequate.	Contact local electrical utility.
	Motor not wired for correct voltage.	Refer to motor name plate for correct wiring.
	Spindle is locked with mandrel lever.	Unlock spindle - see label next to lever on base.
Cuts are unsatisfactory	Dull cutter.	Replace cutter.
	Gum or pitch on cutter.	Remove cutter and clean with solvent.
	Cutterhead rotating in the wrong direction.	Check for proper rotation at start up.
	Feeding work in the wrong direction.	Feed work against the cutter rotation.
Machine vibrates.	Cutterhead damaged.	Replace cutterhead.
	Stand on uneven surface.	Stand must rest solidly on level surface, bolt to floor if necessary.
	Defective V-belt.	Replace V-belt.
	V-belt incorrectly tensioned.	Apply proper tension.
	Bent pulley.	Replace pulley.
	Motor mounted improperly.	Motor must be properly mounted with snug nuts and bolts.
Edge splits off on cross grain cut.	Characteristic of this type of cut.	Make cross grain cuts first, then finish cut with the grain.
		Use scrap block to support end of cut.
Raised areas on shaped edge.	Variation of pressure holding work against cutter.	Hold work firmly against table and fence. Use hold-downs.

Trouble	Probable Cause	Remedy
Work pulled from hand.	Feeding work in the wrong direction.	Always feed work against the rotation of the cutterhead.
Depth of cut not uniform.	Fence misalignment.	Align outfeed fence.
	Side pressure not uniform.	Use holddowns; keep constant pressure against fence.
Work burns.	Cutting too deep on one pass.	On hardwoods take light cuts; attain full depth with several passes.
	Forcing work.	Feed work slowly and steadily.
Cut height not uniform.	Variation in pressure holding work to table.	Keep pressure firm throughout pass. Use hold-downs. Make pass slowly and steadily. Keep work under cutter whenever possible.
Cuts not smooth.	Wrong R.P.M.	Use faster speed.
	Feeding too fast.	Slow feed speed.
	Working against the grain.	Work with the grain whenever possible.
	Cutting too deep on one pass.	Take several passes on very deep cuts.
Spindle does not raise freely.	Sawdust or dirt in raising mechanism.	Brush or blow out dirt and saw dust. Lubricate regularly.

Replacement Parts

Replacement parts are listed on the following pages. To order parts or reach our service department, call 1-800-274-6848 Monday through Friday, 8:00 a.m. to 5:00 p.m. CST. Having the Model Number and Serial Number of your machine available when you call will allow us to serve you quickly and accurately.

Non-proprietary parts, such as fasteners, can be found at local hardware stores, or may be ordered from JET. Some parts are shown for reference only, and may not be available individually.

Table and Fence Breakdown

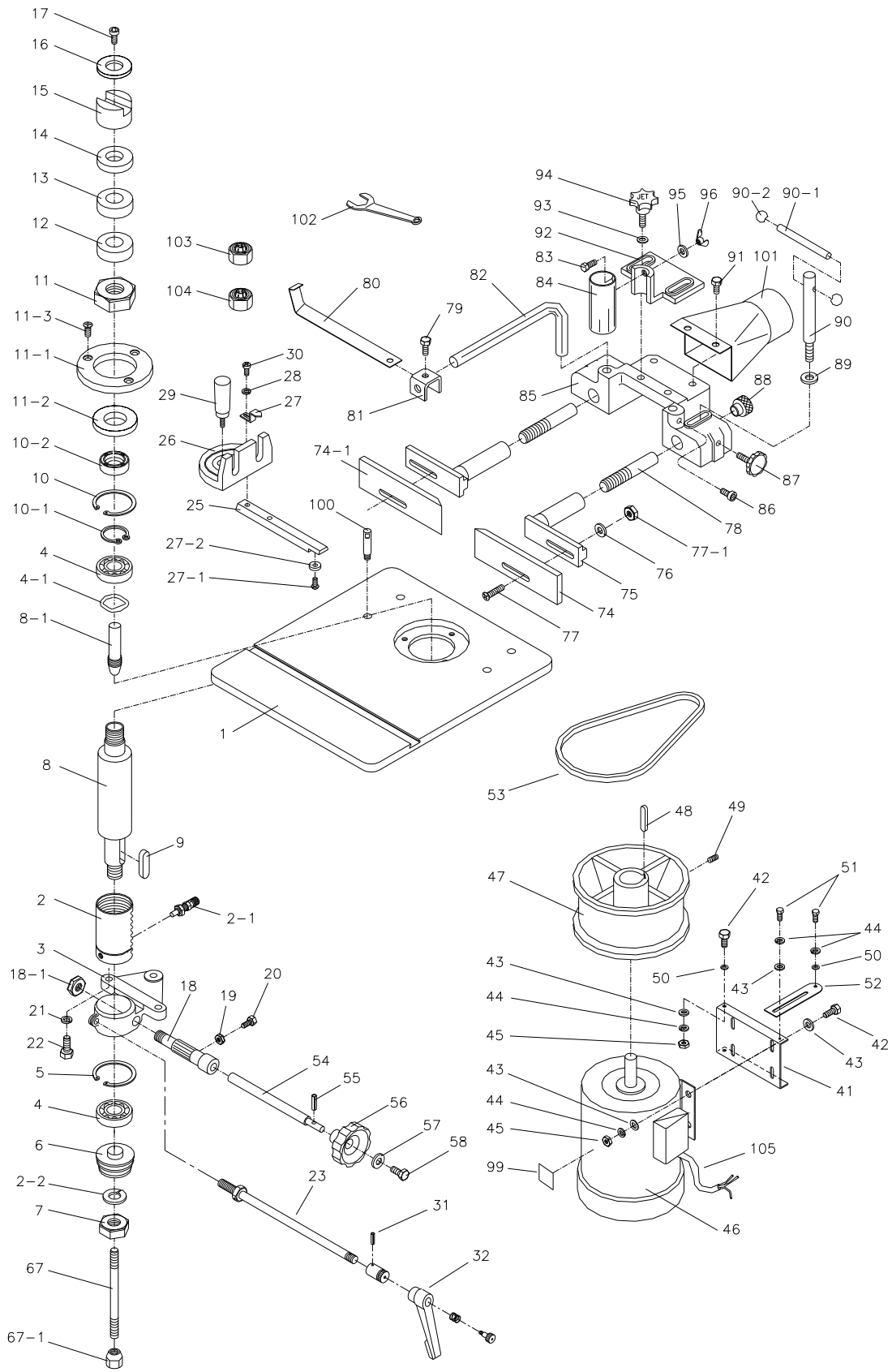

Parts List

Index No.	Part No.	Description	Size	Qty
1	JWS22CS-1	Table		1
2	JWS22CS-2	Spindle Housing		1
2-1	JWS22CS-2-1	Spindle Locking Mandrel		1
2-2	JWS22CS-2-2	Lock Washer	M18.5	1
3	JWS18HO-3	Cutter Spindle Bracket		1
4	BB-6005ZZ	Ball Bearing		2
4-1	JWS18HO-4-1	Wave Washer		1
5	JWS18HO-5	Snap Ring		1
6	JWS22CS-6	Pulley		1
7	TS-0561082	Hex Nut	3/4x16UNF	1
8	JWS22CS-8	Main Spindle		1
8-1	JWS18HO-8-1	Shaft (1/2)		1
	JWS18HO-8-1A	Shaft ** (3/4-not shown)		1
9	JWS22CS-9	Key		1
10	JWS18HO-10	Snap Ring (spindle housing)		1
10-1	JWS18HO-10-1	Snap Ring (main spindle)		1
10-2	OS-25478	Oil Seal		1
11	JWS18HO-11	Hex Nut (spindle)		1
	JWS18HO-TRA	Table Ring Assembly (includes #11-1, 11-2)		1
11-1	JWS18HO-11-1	Table Ring, Large (<i>serial # 0092192 and lower</i>) (RE: JWS18HO-TRA)		1
11-1	JWS18HO-11-1N	Table Ring, Large (<i>serial # 0092193 and higher</i>) (RE: JWS18HO-TRA)		1
11-2	JWS18HO-11-2	Table Ring, Small (RE: JWS18HO-TRA)		1
11-3	JSL10TS-7	Phillip's Screw	1/4"x5/8"	3
12	JWS18HO-12	Spacer (1/2)	80	1
	JWS18HO-12A	Spacer ** (3/4-not shown)	1.00	1
13	JWS18HO-13	Spacer (1/2)	60	1
	JWS18HO-13A	Spacer ** (3/4-not shown)	75	1
14	JWS18HO-14	Spacer (1/2)	40	1
14A	JWS18HO-14A	Spacer ** (3/4-not shown)	0.50	1
15	JWS18HO-15	Fixed Bushing (1/2)		1
	JWS18HO-15A	Fixed Bushing ** (3/4-not shown)		1
16	JWS18HO-16	Washer (1/2)		1
	JWS18HO-16A	Washer ** (3/4-not shown)		1
17	TS-0208061	Hex Cap Bolt (1/2)	5/16x1	1
	TS-0209051	Hex Cap Bolt ** (3/4-not shown)	3/8x1	1
18	JWS18HO-18	Quill		1
18-1	JWS18HO-18-1	Nut	1/2-20 UNF	1
19	TS-0561021	Hex Nut	5/16	1
20	TS-0051031	Hex Head Bolt	5/16x5/8	1
21	JWS18HO-21	Lock Washer	1/2	3
22	TS-0070041	Hex Cap Bolt	1/2x1-3/4	3
23	JWS22CS-23	Lock Bar		1
25	JSL10TS-6	Guide Plate		1
26	JSL10TS-3	Miter Gauge Body		1
27	JWS18HO-27	Plate		1
27-1	JWS18HO-27-1	Flat Head Screw	3/16x1/4	1
27-2	JWS18HO-27-2	Washer (special)		1
28	JWS18HO-28	Washer		1
29	JSL10TS-1	Knob		1
30	JWS18HO-30	Screw	3/16x1/4	1
31	JWS22CS-31	Spring Pin	M3x19	1
32	JWS22CS-32	Lock Handle		1
33	TS-0680041	Lock Washer	1/4	2
34	JWS22CS-34	Motor Cover		1
35	JWS22CS-35	Cabinet Cover		1
36	JTAS10-45	Handle		1
37	TS-0720091	Lock Washer	3/8	4
38	TS-1540021	Hex Nut	M6	1

Note: (1/2) and (3/4) refer to 1/2" or 3/4" spindles

Index No.	Part No.	Description	Size	Qty
39	JTAS10-41	Spring		1
40	TS-1482101	Hex Cap Screw	M6x50	1
41	JWS22CS-41	Motor Plate		1
42	TS-0208061	Hex Cap Bolt	5/16x1	6
43	TS-0680031	Washer	5/16	9
44	TS-0720081	Lock Washer	5/16	8
45	TS-0561021	Hex Nut	5/16	6
46	JWS22CS-46	Motor		1
47	JWS18HO-47	Motor Pulley		1
48	JWS18HO-48	Key		1
49	JWS18HO-49	Set Screw	1/4x3/8	1
50	JWS22CS-50	Washer	5/16x18	5
51	TS-0081031	Hex Cap Screw	5/16x3/4	2
52	JWS22CS-52	Motor Plate Bracket		1
53	VB-M23	V-Belt		1
54	JWS22CS-54	Feed Bar		1
55	JWS18HO-55	Spring Pin	M3x18	1
56	JWS18HO-56	Handle		1
57	TS-0680021	Washer	1/4	1
58	TS-0050021	Hex Cap Bolt	1/4 x 5/8	1
59	JWS18HO-59	Switch Assembly (includes #61,62,63,64,107,109)		1
59-2	JWS22CS-59-2	Strain Relief		3
59-3	JWS18HO-59-3	Switch Cover		1
59-4	JWS22CS-59-4	Plate		1
60	JWS22CS-60	Cabinet		1
61	JWS18HO-61	Plate		1
62	JWS18HO-62	Screw		4
63	JWS18HO-63	Switch Plate		1
64	JWS18HO-64	Switch Handle		1
65	JWS22CS-65	Power Cord		1
66	JTAS10-28	Tap Screw	M5x10	4
67	JWS22CS-67	Draw Bar	5/16x6	1
67-1	JWS22CS-67-1	Taper Nut		1
68	JWS22CS-68	Strain Relief		2
69	JWS22CS-69	Cord Plate		1
70	JTAS10-47	Cord Clamp Plate		1
71	JWS22CS-71	Power Cord Sleeve		1
72	JWS22CS-72	Foam Strip		1
73	JWS22CS-73	Rubber Padding		2
74	JWS18HO-74	Fence (right)		1
74-1	JWS18HO-74-1	Fence (left)		1
75	JWS18HO-75	Guide Bar		2
76	TS-0680031	Washer	5/16	2
77	JWS18HO-77	Flat Head Machine Screw	5/16x1-3/4	2
77-1	TS-0561021	Hex Nut	5/16	2
78	JWS18HO-78	Lead Screw		2
79	TS-0050031	Hex Cap Bolt	1/4x3/4	2
80	JWS18HO-80	Guide Plate		2
81	JWS18HO-81	Slide Block		2
82	JWS18HO-82	Guide Plate Support		2
83	TS-0060051	Hex Cap Bolt	3/8x1	1
84	JWS18HO-84	Safety Shield		1
85	JWS18HO-85	Fence Body		1
86	TS-0209021	Hex Socket Cap Bolt	3/8x5/8	2
87	JWS18HO-87	Lock Knob	3/8	2
88	JWS18HO-88	Knob		2
	JWS18HO-90A	Lock Handle Assembly (Pair)(index #89 thru 90-2)		1
89	TS-0680061	Washer	1/2	2
90	JWS18HO-90	Lock Handle		2
90-1	JWS18HO-90-1	Handle	1/4	2
90-2	JWS18HO-90-2	Plastic Ball	1/4	4

Index No.	Part No.	Description	Size	Qty
91	TS-0050051	Hex Cap Bolt	1/4x1/2	2
92	JWS18HO-92	Safety Shield Mount		1
93	TS-0680031	Washer	5/16	2
94	JWS18HO-94	Knob	5/16x1	2
95	TS-0680041	Washer	3/8	1
96	JWS18HO-96	Butterfly Nut		1
97	JWS18HO-97	Label		1
98	JWS18HO-98	Warning Label		1
99	JWS18HO-99	Motor Name Plate		1
100	JWS18HO-100	Stop Pin		2
101	JWS18HO-101	Dust Chute		1
102	JWS22CS-102	Spanner Wrench **		1
103	JWS22CS-103	Collet w/Nut**	1/4	1
104	JWS22CS-104	Collet w/Nut**	1/2	1
105	JWS22CS-105	Motor Cord		1
106	TS-0207021	Hex Cap Bolt	1/4x1/2	4
107	JWS18HO-107	Screw		1
108	JWS22CS-108	Lock Out Bracket		1
109	JWS18HO-109	Nut		6
110	JWS22CS-110	I.D. Label		1
111	JWS22CS-111	Label (spindle direction)		1
112	JWS22CS-112	Label (spindle lock)		1
	JWS22CS-MGCP	Miter Gauge Complete (includes # 25 thru 30)		1
	JWS22HO-HK	Hardware Kit (shaper - not shown)		1
	JWS18HO-FACP	Fence Assy Complete (not shown)		1
	JWS22CS-AP	Accessory Package		1
	STRIPE-1-3/4	JET Stripe (not shown)		per ft.

** included in JWS22CS-HK, Hardware Kit

Electrical Schematic

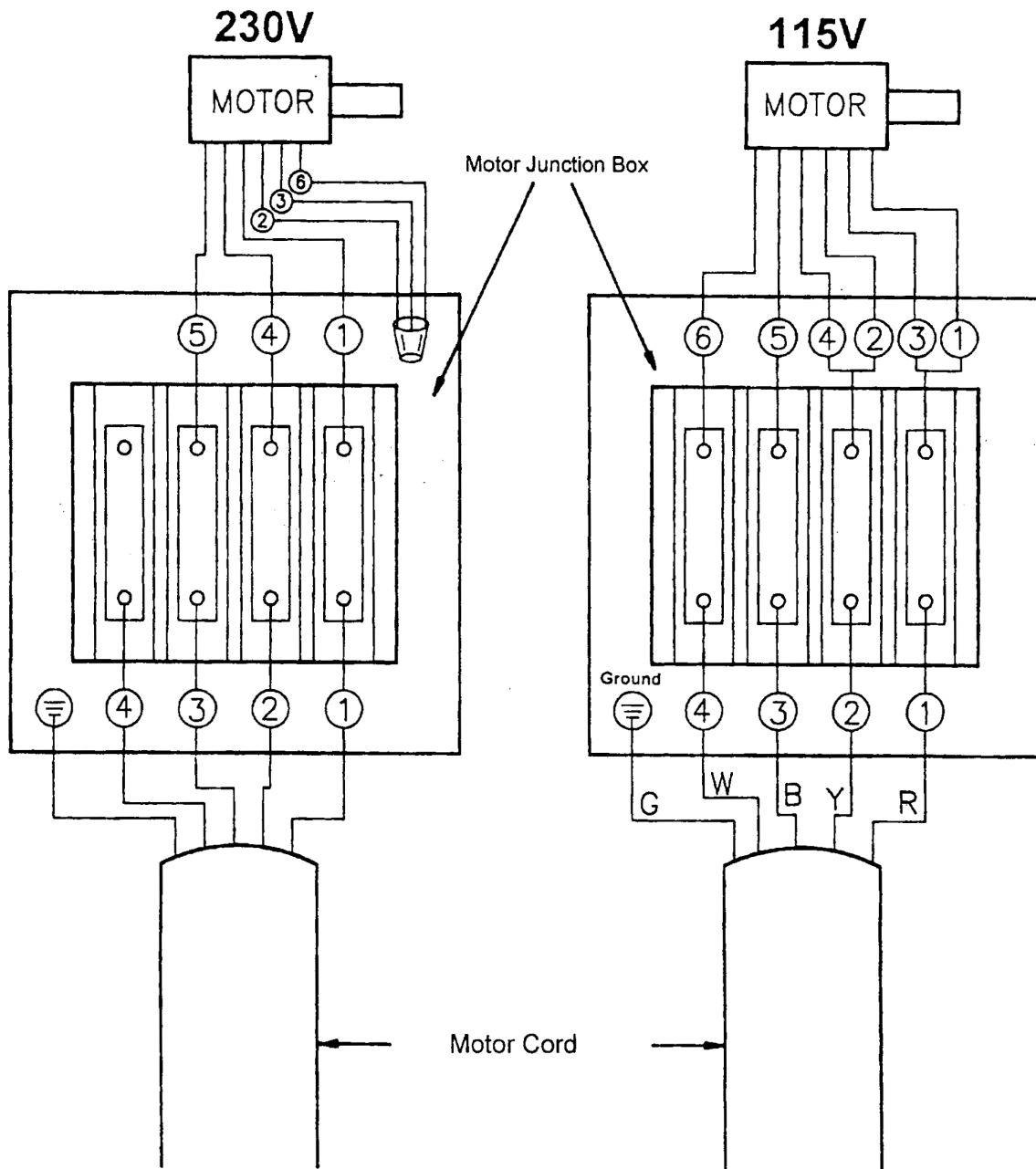

Electrical Schematic for the Forward/Reverse Switch

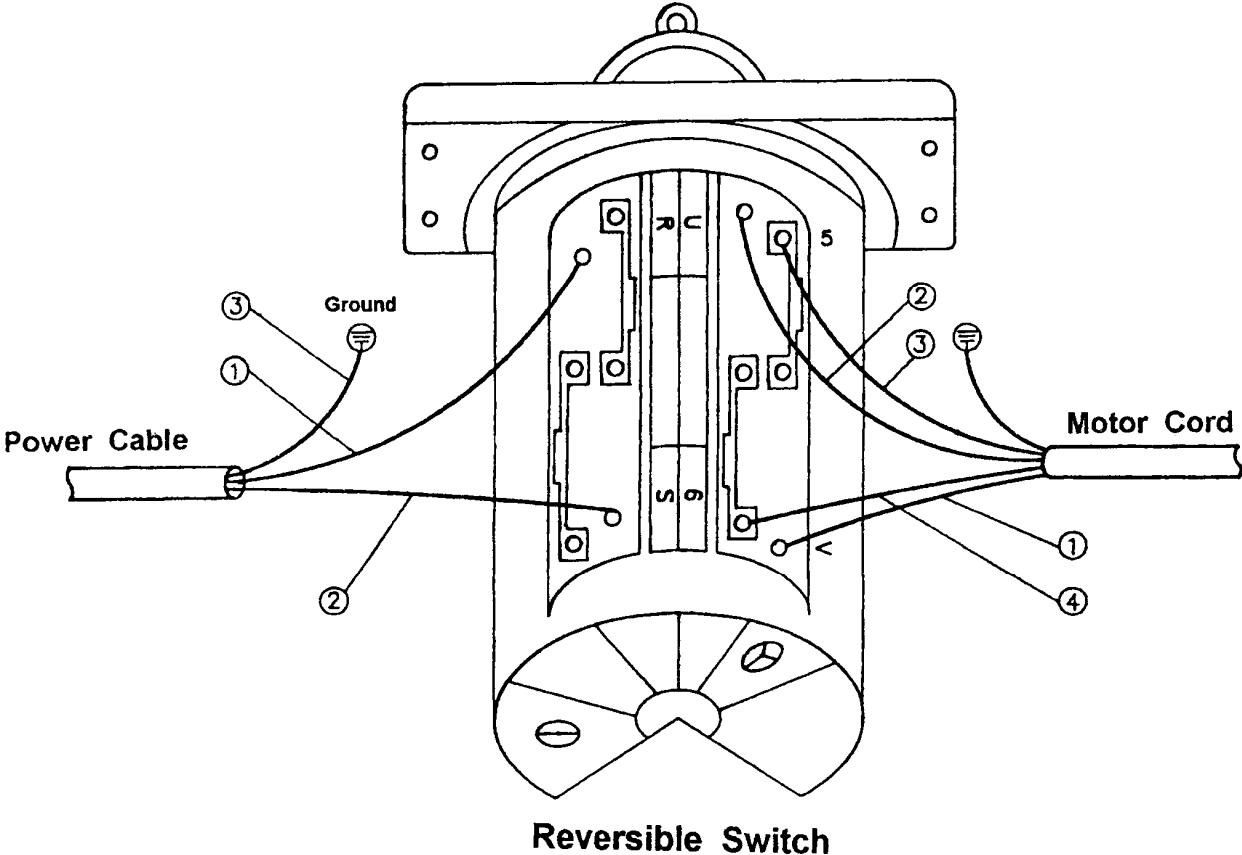



427 New Sanford Road
LaVergne, Tennessee 37086
Phone: 800-274-6848
www.jettools.com