



Operating Instructions and Parts Manual

10" Sliding Dual Bevel Compound Miter Saw

Benchtop Series – Model No. JMS-10SCMS



JET
427 New Sanford Road
LaVergne, Tennessee 37086
Ph.: 800-274-6848
www.jettools.com

Part No. M-707110
Revision B3 05/2014
Copyright © 2014 JET

Warranty and Service

JET warrants every product it sells against manufacturers' defects. If one of our tools needs service or repair, please contact Technical Service by calling 1-800-274-6846, 8AM to 5PM CST, Monday through Friday.

Warranty Period

The general warranty lasts for the time period specified in the literature included with your product or on the official JET branded website.

- JET products carry a limited warranty which varies in duration based upon the product. (See chart below)
- Accessories carry a limited warranty of one year from the date of receipt.
- Consumable items are defined as expendable parts or accessories expected to become inoperable within a reasonable amount of use and are covered by a 90 day limited warranty against manufacturer's defects.

Who is Covered

This warranty covers only the initial purchaser of the product from the date of delivery.

What is Covered

This warranty covers any defects in workmanship or materials subject to the limitations stated below. This warranty does not cover failures due directly or indirectly to misuse, abuse, negligence or accidents, normal wear-and-tear, improper repair, alterations or lack of maintenance.

Warranty Limitations

Woodworking products with a Five Year Warranty that are used for commercial or industrial purposes default to a Two Year Warranty. Please contact Technical Service at 1-800-274-6846 for further clarification.

How to Get Technical Support

Please contact Technical Service by calling 1-800-274-6846. **Please note that you will be asked to provide proof of initial purchase when calling.** If a product requires further inspection, the Technical Service representative will explain and assist with any additional action needed. JET has Authorized Service Centers located throughout the United States. For the name of an Authorized Service Center in your area call 1-800-274-6846 or use the Service Center Locator on the JET website.

More Information

JET is constantly adding new products. For complete, up-to-date product information, check with your local distributor or visit the JET website.

How State Law Applies

This warranty gives you specific legal rights, subject to applicable state law.

Limitations on This Warranty

JET LIMITS ALL IMPLIED WARRANTIES TO THE PERIOD OF THE LIMITED WARRANTY FOR EACH PRODUCT. EXCEPT AS STATED HEREIN, ANY IMPLIED WARRANTIES OF MERCHANTABILITY AND FITNESS FOR A PARTICULAR PURPOSE ARE EXCLUDED. SOME STATES DO NOT ALLOW LIMITATIONS ON HOW LONG AN IMPLIED WARRANTY LASTS, SO THE ABOVE LIMITATION MAY NOT APPLY TO YOU.

JET SHALL IN NO EVENT BE LIABLE FOR DEATH, INJURIES TO PERSONS OR PROPERTY, OR FOR INCIDENTAL, CONTINGENT, SPECIAL, OR CONSEQUENTIAL DAMAGES ARISING FROM THE USE OF OUR PRODUCTS. SOME STATES DO NOT ALLOW THE EXCLUSION OR LIMITATION OF INCIDENTAL OR CONSEQUENTIAL DAMAGES, SO THE ABOVE LIMITATION OR EXCLUSION MAY NOT APPLY TO YOU.

JET sells through distributors only. The specifications listed in JET printed materials and on official JET website are given as general information and are not binding. JET reserves the right to effect at any time, without prior notice, those alterations to parts, fittings, and accessory equipment which they may deem necessary for any reason whatsoever. JET® branded products are not sold in Canada by JPW Industries, Inc.

Product Listing with Warranty Period

90 Days – Parts; Consumable items; Light-Duty Air Tools
1 Year – Motors; Machine Accessories; Heavy-Duty Air Tools; Pro-Duty Air Tools
2 Year – Metalworking Machinery; Electric Hoists, Electric Hoist Accessories; Woodworking Machinery used for industrial or commercial purposes
5 Year – Woodworking Machinery
Limited Lifetime – JET Parallel clamps; VOLT Series Electric Hoists; Manual Hoists; Manual Hoist Accessories; Shop Tools; Warehouse & Dock products; Hand Tools

NOTE: JET is a division of JPW Industries, Inc. References in this document to JET also apply to JPW Industries, Inc., or any of its successors in interest to the JET brand.

Table of Contents

Warranty and Service	2
Table of Contents	3
Warnings	4
Compound Miter Saw Safety.....	6
Introduction.....	7
Specifications	7
Cutting Capacity	7
Electrical.....	8
Features	9
Shipping Contents	10
Assembly.....	10
Adjustments.....	14
Operation.....	19
Crown Molding Chart	26
Maintenance.....	27
Troubleshooting – Motor	28
Troubleshooting – Operation.....	28
Parts.....	29
Wiring Diagram.....	36

The specifications in this manual are given as general information and are not binding. JET reserves the right to effect, at any time and without prior notice, changes or alterations to parts, fittings, and accessory equipment deemed necessary for any reason whatsoever.



Warnings

1. Read and understand the entire owners' manual before attempting assembly or operation.
2. Read and understand the warnings posted on the machine and in this manual. Failure to comply with all of these warnings may cause serious injury.
3. Replace the warning labels if they become obscured or removed.
4. This saw is designed and intended for use by properly trained and experienced personnel only. If you are not familiar with the proper and safe operation of a compound miter saw, do not use until proper training and knowledge have been obtained.
5. Do not use this saw for other than its intended use. If used for other purposes, JET disclaims any real or implied warranty and holds itself harmless from any injury that may result from that use.
6. Always wear approved safety glasses/face shields while using this miter saw. Everyday eyeglasses only have impact resistant lenses; they are not safety glasses.
7. Before operating this saw, remove tie, rings, watches and other jewelry, and roll sleeves up past the elbows. Remove all loose clothing and confine long hair. Non-slip footwear or anti-skid floor strips are recommended. Do **not** wear gloves.
8. Wear ear protectors (plugs or muffs) during extended periods of operation.
9. Some dust created by power sanding, sawing, grinding, drilling and other construction activities contain chemicals known to cause cancer, birth defects or other reproductive harm. Some examples of these chemicals are:
 - Lead from lead based paint.
 - Crystalline silica from bricks, cement and other masonry products.
 - Arsenic and chromium from chemically treated lumber.Your risk of exposure varies, depending on how often you do this type of work. To reduce your exposure to these chemicals, work in a well-ventilated area and work with approved safety equipment, such as face or dust masks that are specifically designed to filter out microscopic particles.
10. Do not operate this machine while tired or under the influence of drugs, alcohol or any medication.
11. Make certain the switch is in the **OFF** position before connecting the machine to the power supply.
12. Make certain the machine is properly grounded.
13. Make all machine adjustments or maintenance with the machine unplugged from the power source.
14. Remove adjusting keys and wrenches. Form a habit of checking to see that keys and adjusting wrenches are removed from the machine before turning it on.
15. Keep safety guards in place at all times when the machine is in use. If removed for maintenance purposes, use extreme caution and replace the guards immediately.
16. Make sure this machine is firmly secured to the floor or bench before use.
17. Check damaged parts. Before further use of the machine, a guard or other part that is damaged should be carefully checked to determine that it will operate properly and perform its intended function. Check for alignment of moving parts, binding of moving parts, breakage of parts, mounting and any other conditions that may affect its operation. A guard or other part that is damaged should be properly repaired or replaced.
18. Provide for adequate space surrounding work area and non-glare, overhead lighting.
19. Keep the floor around the machine clean and free of scrap material, oil and grease.
20. Don't use in dangerous environment. Don't use power tools in damp or wet locations, or expose them to rain. Keep work area well lighted.



Warnings

21. Keep visitors a safe distance from the work area. **Keep children away.**
22. Make your workshop child proof with padlocks, master switches or by removing starter keys.
23. Give your work undivided attention. Looking around, carrying on a conversation and “horse-play” are careless acts that can result in serious injury.
24. Maintain a balanced stance at all times so that you do not fall or lean against the blade or other moving parts. Do not overreach or use excessive force to perform any machine operation.
25. Use the right tool at the correct speed and feed rate. Do not force a tool or attachment to do a job for which it was not designed. The right tool will do the job better and safer.
26. Use recommended accessories; improper accessories may be hazardous.
27. Maintain tools with care. Keep saw blades sharp and clean for the best and safest performance. Follow instructions for lubricating and changing accessories.
28. Disconnect tools before servicing and when changing accessories such as blades.
29. Make sure the work piece is securely attached or clamped to the table.
30. Turn off the machine before cleaning. Use a brush or compressed air to remove chips or debris — do not use your hands.
31. Do not stand on the machine. Serious injury could occur if the machine tips over.
32. Never leave the machine running unattended. Turn the power off and do not leave the machine until it comes to a complete stop.
33. Remove loose items and unnecessary work pieces from the area before starting the machine.

Familiarize yourself with the following safety notices used in this manual:



This means that if precautions are not heeded, it may result in minor injury and/or possible machine damage.



This means that if precautions are not heeded, it may result in serious injury or possibly even death.

Compound Miter Saw Safety

Specific safety instructions for this compound miter saw:

1. Do not operate the miter saw until it is completely assembled and installed according to these instructions.
2. If you are not thoroughly familiar with the operation of miter saws, seek guidance from your supervisor, instructor or other qualified person.
3. Always hold the work firmly against the fence and table.
4. Do not perform any operation free hand (use clamp wherever possible).
5. Keep hands out of the path of the saw blade. If the workpiece you are cutting would cause your hands to be within 8-3/4 in. of the saw blade, the workpiece should be clamped in place before making the cut.
6. Be sure the blade is sharp, runs freely and is free of vibration.
7. Allow the motor to come up to full speed before starting a cut.
8. Keep the motor air slots clean and free of chips or dust.
9. Always make sure all handles are tight before cutting, even if the table is positioned in one of the positive stops.
10. Be sure both the blade and the collar are clean and the arbor bolt is tightened securely.
11. Use only blade collars specified for your saw.
12. Never use blades larger in diameter than 10 inches.
13. Never apply lubricants to the blade when it is running.
14. Always check the blade for cracks or damage before operation. Replace a cracked or damaged blade immediately.
15. Never use blades recommended for operation at less than 4200 RPM.
16. Always keep the blade guards in place and use at all times.
17. Never reach around the saw blade.
18. Make sure the blade is not contacting the workpiece before the switch is turned ON.
19. Important: After completing the cut, release the trigger and wait for the blade to stop before returning the saw to the raised position.
20. Make sure the blade has come to a complete stop before removing or securing the workpiece, changing the workpiece angle or changing the angle of the blade.
21. Never cut metals or masonry products with this tool. This miter saw is designed for use on wood and wood-like products.
22. Never cut small pieces. If the workpiece being cut would cause your hand or fingers to be within 8-3/4 in. of the saw blade the workpiece is too small.
23. Provide adequate support to the sides of the saw table for long work pieces.
24. Never use the miter saw in an area with flammable liquids or gases.
25. Never use solvents to clean plastic parts. Solvents could possibly dissolve or otherwise damage the material.
26. Shut off the power before servicing or adjusting the tool.
27. Disconnect the saw from the power source and clean the machine when finished using.
28. Make sure the work area is clean before leaving the machine.
29. Should any part of your miter saw be missing, damaged, or fail in any way, or any electrical component fail to perform properly, lock the switch and remove the plug from the power supply outlet. Replace missing, damaged, or failed parts before resuming operation.

Introduction

This manual is provided by JET covering the safe operation and maintenance procedures for the JET Model JMS-10SCMS *Dual Bevel Sliding Compound Miter Saw* with laser. This manual contains instructions on installation, safety precautions, general operating procedures, maintenance instructions and parts breakdown. This machine has been designed and constructed to provide years of trouble free operation if used in accordance with instructions set forth in this manual. If there are any questions or comments, please contact either your local supplier or JET. JET can also be reached at our web site: www.jettools.com.

Specifications

Model Number.....	JMS-10SCMS
Stock Number.....	707110
Motor.....	120V, 60Hz, 15A
No Load Speed (Arbor).....	4200RPM
Motor Arbor Shaft Size	5/8"
Blade.....	10", 40T, carbide tipped
Blade Arbor Size	5/8"
Miter Stops.....	10 stops, -45° to 60°
Bevel Stops	0°, 33.9° and 45° left and right
Base Dimensions (WxD).....	37-1/2" x 26-1/4"
Footprint, without optional extensions (WxD)*	41" x 42"
Cord Length	7'-6"
Net Weight	51 lbs.
Shipping Weight	56 lbs.

* Space required for full range of miter, bevel and slide motions

The above specifications were current at the time this manual was published, but because of our policy of continuous improvement, JET reserves the right to change specifications at any time and without prior notice, without incurring obligations.

Cutting Capacity

Cut Type	Miter Angle	Bevel Angle	Cutting Capacity
Cross Cut	0°	0°	3-5/8" x 12"
Miter	45° Right & Left	0°	3-5/8" x 8"
Miter	60° Right	0°	3-5/8" x 5-3/4"
Bevel	0°	45° Left	1-5/8" x 12"
Bevel	0°	45° Right	1-3/8" x 12"
Compound Cut	45° Right & Left	45° Left	1-5/8" x 8"
Compound Cut	45° Right & Left	45° Right	1-3/8" x 8"
Compound Cut	60° Right	45° Right	1-3/8" x 5-3/4"
Vertical Capacity (Baseboard)	0°	0°	4-3/4"

⚠WARNING Read and understand the entire contents of this manual before attempting assembly or operation! Failure to comply may cause serious injury!

Electrical

Power Supply and Motor Specifications

The AC motor used in this saw is a universal, nonreversible type (see *Motor* in the *Specifications* section on page 7).

⚠WARNING To avoid electrical hazards, fire hazards, or damage to the machine, use proper circuit protection. Your saw is wired at the factory for 120V operation. Connect to a 120V, 15 Amp circuit and use a 15 amp time delay fuse or circuit breaker. If power cord is worn or cut, or damaged in any way, have it replaced immediately to avoid shock or fire.

Electrical Requirements

This machine is double insulated to provide a double thickness of insulation between the user and the machine's electrical system. All exposed metal parts are isolated from the internal metal motor components with protective insulation.

This saw has a plug that looks like the one shown in Figure A.

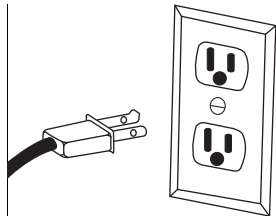

Figure A

To reduce the risk of electrical shock, this saw has a polarized plug (one blade is wider than the other). This plug will fit in a polarized outlet only one way; if the plug does not fit fully in the outlet, reverse the plug. If it still does not fit, contact a qualified electrician to install the proper outlet. Do not change the plug in any way.

Double insulation does not take the place of normal safety precautions when operating this tool.

To avoid electrocution:

1. Use only identical replacement parts when servicing a tool with double insulation. Servicing should be performed by a qualified technician.
2. Do not use power tools in wet or damp locations or expose them to rain or snow.

Extension Cords

Make sure your extension cord is in good condition. When using an extension cord, be sure to use one heavy enough to carry the current your machine will draw. An undersized cord will cause a drop in the line voltage resulting in power loss and overheating. The table below shows the correct size to use depending on the cord length and nameplate ampere rating. If in doubt, use the next heavier gauge. Remember, the smaller the gauge number, the heavier the cord.

Cord Length	AWG
0 – 25ft	16
5 – 50ft	14

Important: Make certain the receptacle in question is properly grounded. If you are not sure, have a registered electrician check the receptacle.

Features

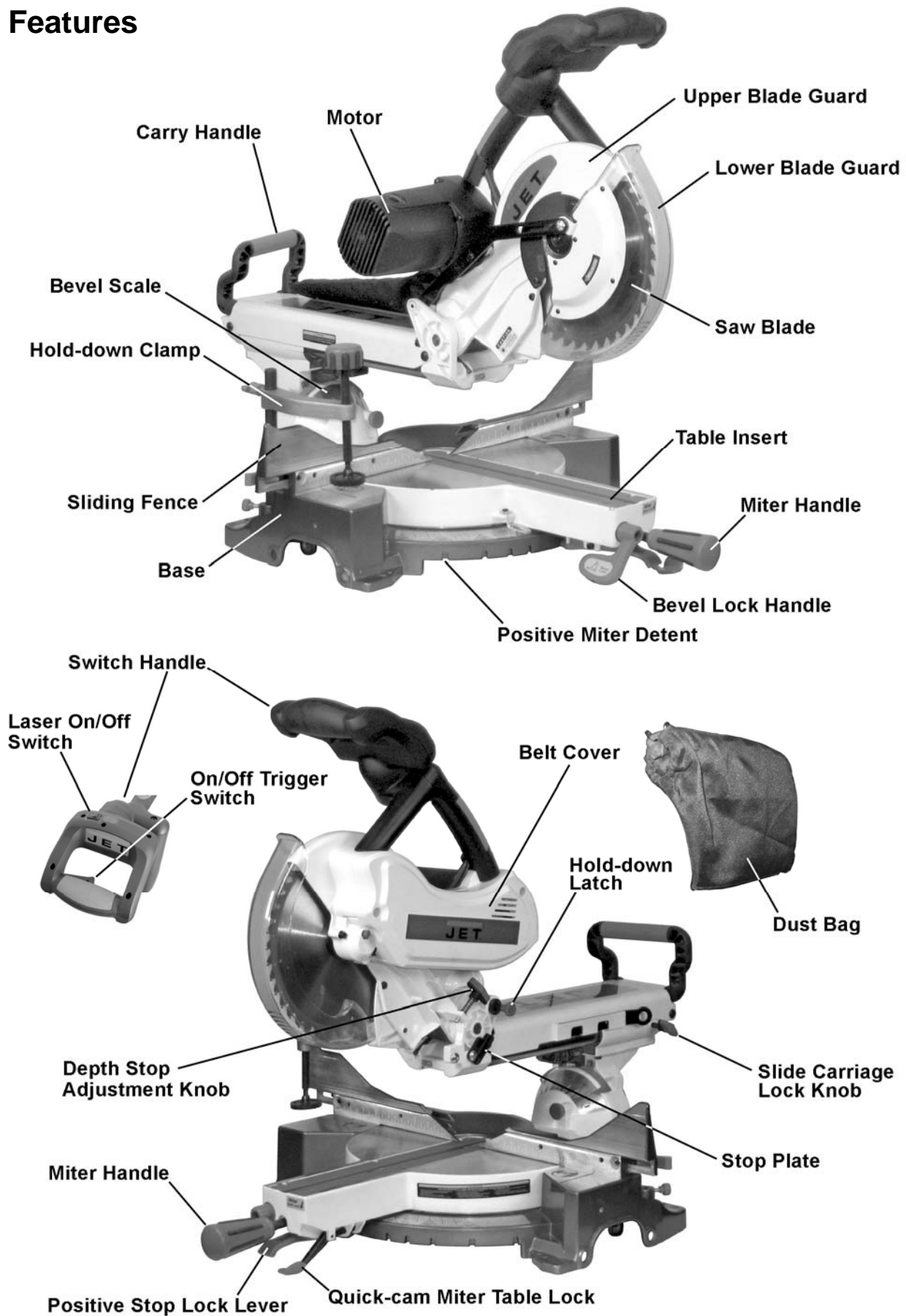

Shipping Contents

Unpacking

1. Remove the contents from the shipping container.
2. Compare the contents of the shipping container with the list found below. Make certain that all items are accounted for before discarding any packing material. Report any shortages or damage to your JET distributor.

Contents of the Shipping Container

- A Compound Miter Saw (1)
- B Dust Bag (1)
- C Hold-down Clamp (1)
- D Lock Knob (2)
- Owner's Manual (1)
- Warranty Registration Card

Tools Supplied for Assembly

- E Blade Wrench

Tools not included

- Adjustable Wrench
- 6mm Hex Wrench
- Crosspoint Screwdriver
- Slotted Screwdriver
- Combination Wrench

⚠WARNING Read and understand all assembly instructions before attempting assembly! Failure to comply may cause serious injury!

Note: Optional work support extensions (stock no. 707111) are available for your miter saw. Contact Walter Meier customer service to order.

Assembly

Unlocking the Slide Carriage

Loosen the slide carriage *lock knob* (A).

When transporting or storing the miter saw, the *slide carriage* (B) should always be locked in position.

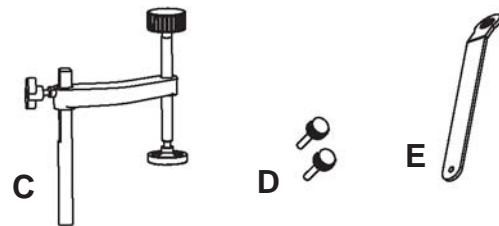
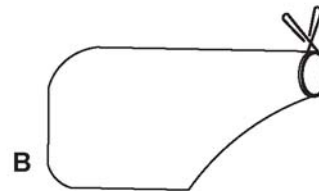
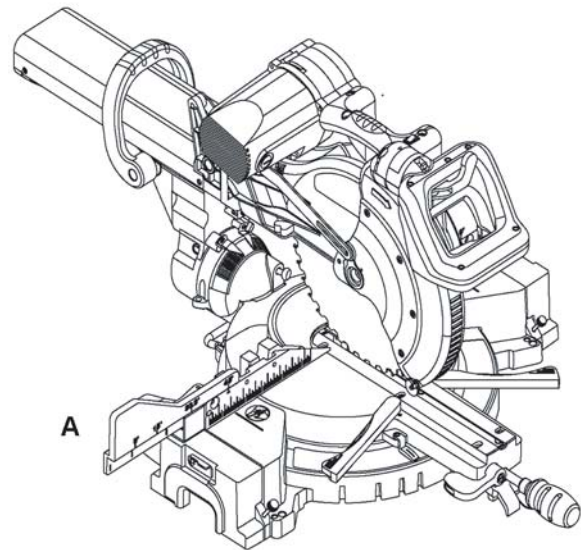

Contents of Shipping Container

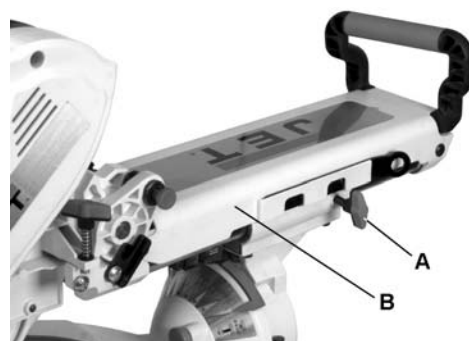

Figure 1

Releasing the Cutting Head

⚠WARNING When not in use, lock the cutting head in the down position. Failure to comply can cause serious injury or damage equipment.

Unlocking

1. Push down on the *switch handle* (page 9).
2. Pull out the *hold-down latch* (A, Fig. 2).
3. Raise the cutting head to the up position.

Locking

Note: When not in use, lock the cutting head in the down position.

1. Push the cutting head down
2. Press the *hold-down latch* (A, Fig. 2) in to lock.

Important: Always use the carrying handles when lifting or moving to avoid damage to the machine.

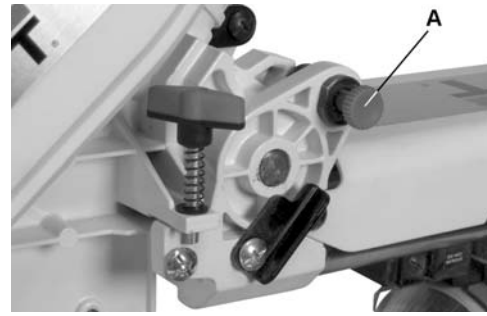

Figure 2

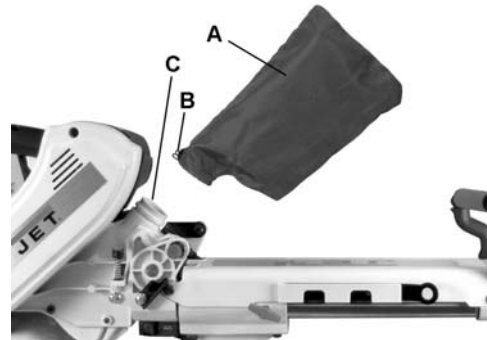

Figure 3

Installing the Dust Bag

1. Squeeze the metal *collar wings* (B, Fig. 3) of the dust bag (A, Fig. 3).
2. Place the dust bag neck opening around the exhaust port (C, Fig. 3), and release the *collar wings* (B).

To empty the dust bag, remove from exhaust port, open zipper on underside of bag and empty into waste container.

Note: Check and empty bag frequently. Do not wait for it to get full.

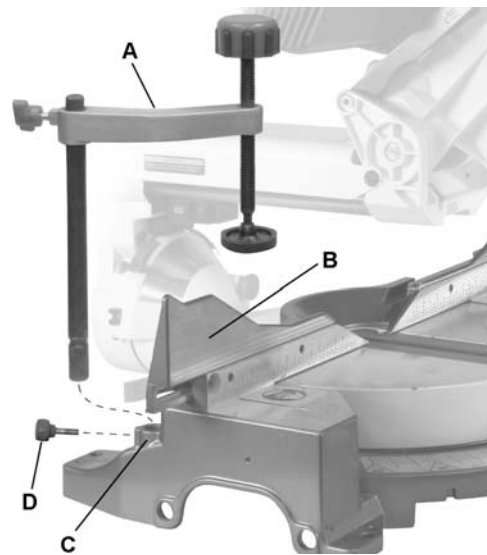

Figure 4

Installing the Safety Hold-down Clamp

1. Place the *hold-down clamp assembly* (A, Fig. 4) in a mounting hole located behind the right or left fence.
2. Thread the *hold-down clamp knob* (D) into the hole located at the rear of the saw base.
3. Tighten the *hold-down clamp knob* (D).

Saw Blade Wrench

For convenience, a *storage clip* (A, Fig. 5) is located on the right side of the sliding carriage for storing the *blade wrench* (B).

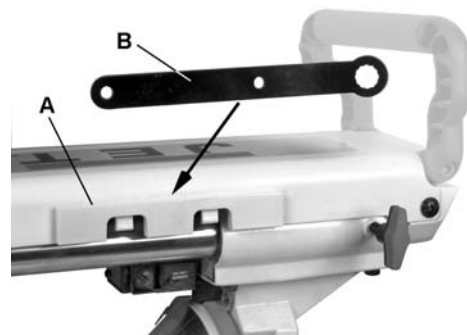

Figure 5

Table Inserts

▲WARNING Always unplug the saw to avoid accidental starting. Failure to comply may cause serious injury!

- ❑ Remove table insert to remove all small pieces of debris from the table cavity before performing any cuts.
- ❑ Be sure to reattach the table insert prior to performing a cutting operation.

▲WARNING Do not start the saw without checking for interference between the blade and table insert.

Damage could result to the blade, table insert or turntable if blade strike occurs during the cutting operation.

To remove:

1. Loosen and remove six screws on the *table inserts* (see page 9) with a crosspoint screwdriver
2. Remove the inserts.

To install:

3. Reposition the table inserts.
4. Install the six screws and tighten.

Check for blade clearance by moving the slide carriage through the full motion of the blade in the table slot.

Mounting the Saw

Observe the following safety measures to avoid injury from unexpected saw movement:

- ❑ Disconnect the power cord and lock the cutting head in the lower position.
- ❑ Lock the slide carriage in place.

When lifting:

- ❑ Use the carrying handles on the top of the saw.
- ❑ Bend at the knees, not from the back.
- ❑ Clamp or bolt the saw on a level work surface.

For stationary use:

Select a location for the saw, such as the top of a workbench, making sure to provide sufficient room for handling the workpiece. Secure the saw to the bench

Mounting hardware is not included and must be purchased separately.

For portable use:

Place the saw on a 3/4 in. thick piece of plywood and bolt the base securely to the plywood using the mounting holes on the base. Mounting hardware is not included and must be purchased separately.

Use C-clamps to clamp this mounting board to a stable work surface at the worksite.

Removing or Installing the Blade

▲WARNING Disconnect power and make sure the switch is in the OFF position to avoid accidental starts. Failure to comply may cause serious injury!

Removing Blade

Referring to Figure 6:

1. Unplug the saw from the outlet.
2. Raise the miter saw to the upright position.
3. Raise the lower *clear plastic blade guard* (A) to the uppermost position.
4. While holding the lower blade guard, loosen the *cover plate screw* (C) with a crosspoint screwdriver.
5. Rotate the *cover plate* (B) to expose the *arbor bolt* (H).
6. Place the *blade wrench* over the *arbor bolt* (H).
7. Locate the *arbor lock* (E) on the motor, below the *belt cover* (D).
8. Press the arbor lock, holding it in firmly while turning the blade clockwise. The arbor lock will then engage and lock the arbor. Continue to hold the arbor lock, while turning the wrench clockwise to loosen the arbor bolt.
9. Remove the *arbor bolt* (H), *arbor collar* (G), and blade (J). Do not remove the inner blade collar.
10. Raise the lower *clear plastic blade guard* (A) to the upright position to remove the blade.

Note: Pay attention to the pieces removed, noting their position and direction they face. Wipe the blade collars clean of any sawdust before installing a new blade.

Installing Blade

Important: This machine requires a 10-inch diameter blade.

Unplug the miter saw before changing and/or installing the blade.

Referring to Figure 6:

1. Install a 10-in. *blade* (J) with a 5/8 in. arbor making sure the rotation arrow on the blade matches the clockwise rotation arrow on the upper guard, and the blade teeth are pointing downward.
2. Place the *arbor collar* (G) against the blade and on the arbor. Thread the *arbor bolt* (H) on the arbor in a counterclockwise direction.

Important: Make sure that the flat edge inside the blade collar opening is aligned with the flat edge on the arbor shaft. Also, the flat -side of the *arbor collar* (G) must be placed against the *blade* (J).

3. Place the blade wrench on the *arbor bolt* (H).
4. Press the *arbor lock* (E), holding it in firmly while turning the blade counterclockwise (opposite the cutting direction of the blade). When it engages, continue to press the *arbor lock* (E) in, while tightening the *arbor bolt* (H) securely.
5. Rotate the *cover plate* (B) back to its original position until the slot in the cover plate engages with the *cover plate screw* (C). While holding the *lower blade guard* (A) up as shown, tighten the *screw* (C) with a cross-point screwdriver.
6. Lower the *retractable blade guard* (A) and verify that the operation of the guard does not bind or stick.
7. Turn the blade to disengage the *arbor lock* (E); then verify that the blade will spin freely.

WARNING Never use the saw without the cover plate securely in place. Failure to comply may cause serious injury!

The cover plate keeps the arbor bolt from falling out if it accidentally loosens, and helps prevent the spinning blade from coming off the saw.

WARNING Verify that the collars are clean and properly installed. Lower the blade into the table and verify that it does not come into contact with the metal base or the turn table. Failure to comply may cause serious injury!

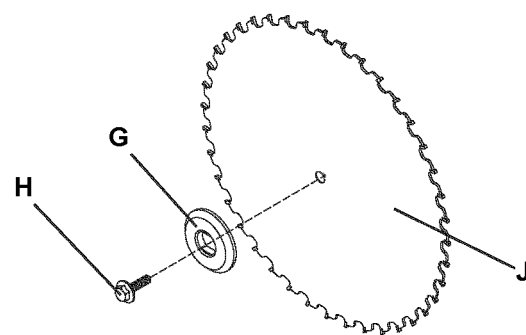
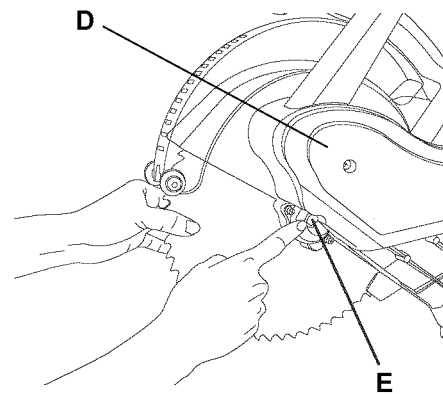
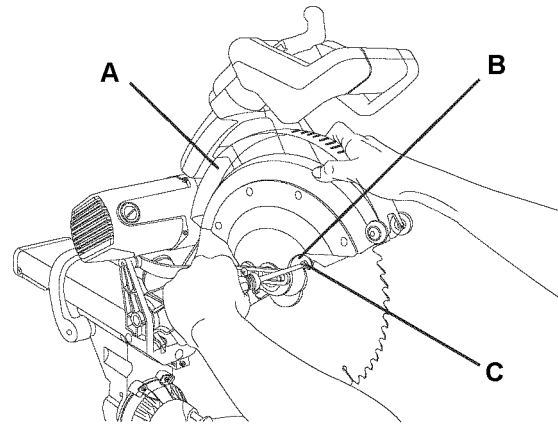

Figure 6

Adjustments

⚠WARNING Before attempting any adjustments – To avoid injury from unexpected starting or electrical shock make sure the trigger is released and remove the power cord from the power source. Failure to comply may cause serious injury!

Note: Your miter saw was adjusted at the factory. However, during shipment slight misalignment may have occurred. Check the following settings and adjust if necessary prior to using this miter saw.

Bevel Stop Adjustments

90°(0°) Bevel Adjustment

1. Set the miter angle to 0°.

Note: A *bevel* angle of 0° corresponds to a *blade-to-miter-table* angle of 90°.

2. Turn the *bevel lock handle* (A, Fig. 8) clockwise to loosen and tilt the cutting arm while pushing the *bevel detent pin* (E, Fig. 10) in against the 0° bevel stop. Turn the *bevel lock handle* (A, Fig. 8) counterclockwise to tighten.
3. Place a combination square on the miter table with the rule against the table and heel of the square against the saw blade.

If the blade is not 0° to the miter table:

4. Using a 4mm hex wrench, loosen four *adjustment screws* (B, Fig. 9) at the back of the miter saw. Pull the *bevel detent pin* (E, Fig. 10) out fully.
5. Unlock the *bevel lock handle* (A, Fig. 8) and position the cutting arm to be zero degrees to the table using the combination square as your reference.
6. When the blade is at zero degrees to the table, turn the *bevel lock handle* (A, Fig. 8) clockwise to tighten.
7. Push in the *bevel detent pin* (E, Fig. 10). If the pin doesn't slide in, the anchor plate needs to be shifted. To do this, move the *adjustment screws* (B, Fig. 9) in their slots until the *bevel detent pin* slides in.
8. Now slide the *adjustment screws* (B, Fig. 9) until the anchor plate rests against the bevel detent pin. Tighten the four *adjustment screws*. (B, Fig. 9). Note: Use the screws to hold the anchor plate against the detent pin while tightening the screws, to prevent slack occurring during the tightening process.



Figure 8

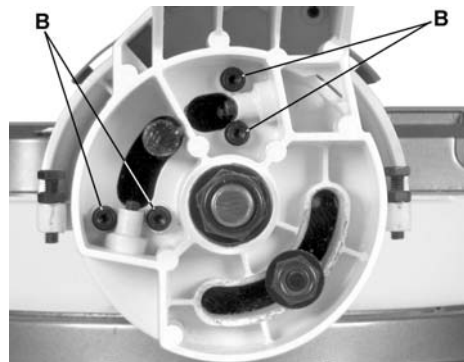

Figure 9

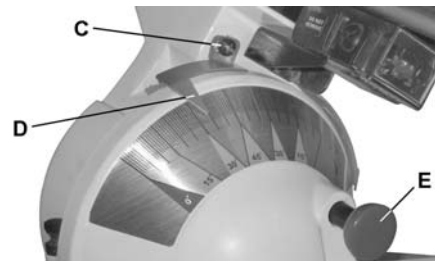

Figure 10

- Test the 90° alignment as follows: Unlock *bevel lock handle* (A, Fig. 8), and pull out *bevel detent pin* (E, Fig. 10). Rotate head left or right, push in *bevel detent pin*, and bring head back to vertical to contact the detent pin. Re-check blade with the square. If needed, repeat the above procedure to get accurate alignment.

Bevel Scale Indicators

- Set the blade to be exactly 90° (0°) to the table.
- With cross-point screwdriver, loosen two *bevel indicator screws* (C, Fig. 10).
- Adjust *bevel indicators* (D, Fig. 10) to the “0” mark on the bevel scale and retighten the *screws* (C, Fig. 10).

45° Left Bevel Positive Stop Adjustment

- Set the miter angle to zero degrees. Fully extend the sliding fence completely to the left then pull the *bevel detent pin* (E, Fig. 10) out.

Note: When retracting the bevel detent pin, it may be required to slightly shift the upper arm assembly right or left.

- Loosen the *bevel lock handle* (A, Fig. 8) and tilt the cutting arm completely to the left (Figure 11).
- Using a combination square, check to see if the blade is 45° to the table.
- To adjust, tilt the cutting arm to zero degrees, loosen the *lock nut* (B, Fig. 12) and turn the *stop bolt* (A, Fig. 12) in or out accordingly.
- Tilt the cutting arm back to the left and recheck alignment.
- Repeat steps 1–4 if necessary until the blade is 45° to the table, then tighten the *lock nut* (B, Fig. 12) to secure the *stop bolt* (A, Fig. 12).

45° Right Bevel Positive Stop Adjustment

- Set the miter angle to zero degrees. Fully extend the sliding fence completely to the right then pull the *bevel detent pin* (E, Fig. 10) out.

Note: When retracting the bevel detent pin, it may be required to slightly shift the upper arm assembly right or left.

- Loosen the *bevel lock handle* (A, Fig. 8) and tilt the cutting arm completely to the right (Figure 13).
- Using a combination square, check to see if the blade is 45° to the table.
- To adjust, tilt the cutting arm to zero degrees, loosen the *locknut* (D, Fig. 12) and turn the *stop bolt* (C, Fig. 12) in or out accordingly.
- Tilt the cutting arm back to the right and recheck alignment.



Figure 11

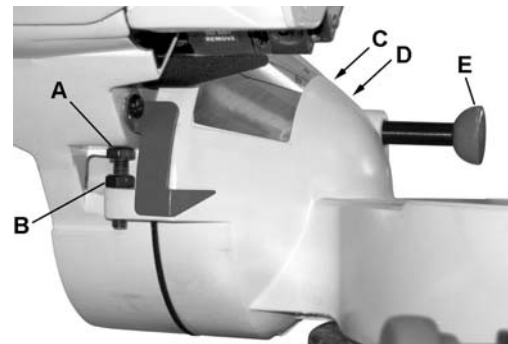

Figure 12



Figure 13

- Repeat steps 1–4 if necessary until the blade is 45° to the table, then tighten the *lock nut* (D, Fig. 12) to secure the *stop bolt* (C, Fig. 12).

33.9° Left & Right Bevel Adjustment

- Set the miter angle to zero degree. Fully extend both sliding fences.
- Loosen the *bevel lock handle* (A, Fig. 8).
- Tilt the cutting arm to the 33.9° left bevel position and engage the positive stop by pushing the *bevel detent pin* (E, Fig. 12) in.
- Using a combination square, check to see if the blade is 33.9° to the table.
- To adjust, turn the *setscrew* (A, Fig. 14) in or out with a 3mm hex wrench until the blade is 33.9° to the table.
- Repeat steps for the right bevel 33.9° bevel adjustment, making adjustments to *setscrew* B, Fig. 15.



Figure 14

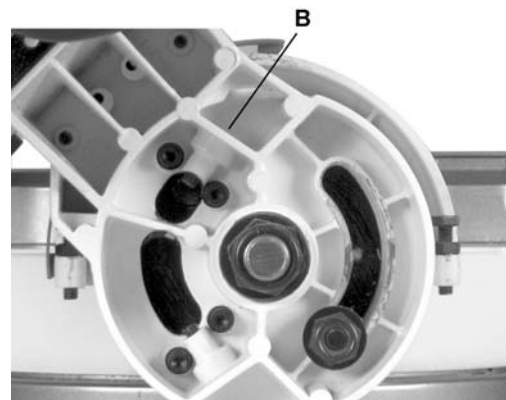

Figure 15

Miter Angle

The sliding compound miter saw scale can be easily read, showing miter angles from 0° to 45° to the left, and 0° to 60° to the right. The miter saw table has ten of the most common angle settings with positive stops at 0°, 15°, 22.5°, 31.6°, and 45° left and right and 60° right. These positive stops position the blade at the desired angle quickly and accurately. Follow the process below for quickest and most accurate adjustments.

Referring to Figure 16:

- Lift up on the quick-cam *miter table lock* (A) to unlock the table.
- Lift up on the *positive stop locking lever* (C) and move the turntable with *handle* (B) to align the *indicator* (D) to the desired degree measurement.
- Lock the table into position by pressing down on the quick-cam *miter table lock* (A).

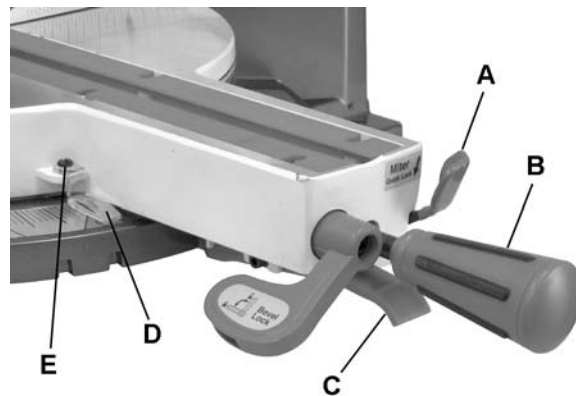

Figure 16

Miter Scale Indicator Adjustment

- Move the table to the 0° positive stop.
- Loosen the screw (E) that holds the indicator with a screwdriver.
- Adjust the *indicator* (D) to the 0° mark and retighten screw.

Adjusting Fence Squareness

1. Loosen four *fence locking screws* (D, Fig. 18).
Note: two locking screws to each fence.
2. Lower the cutting arm and lock in position.
3. Using a *square*, lay the heel (B, Fig. 17 of the square against the *blade* (A) and the *ruler* (C) against the *fence* (D).
4. Adjust the fence 90° to the blade and tighten the four fence locking screws.

CAUTION If the saw has not been used recently, recheck blade squareness to the fence and readjust if needed.

5. After fence has been aligned, using a scrap piece of wood, make a cut at 90° then check squareness on the piece. Readjust if necessary.

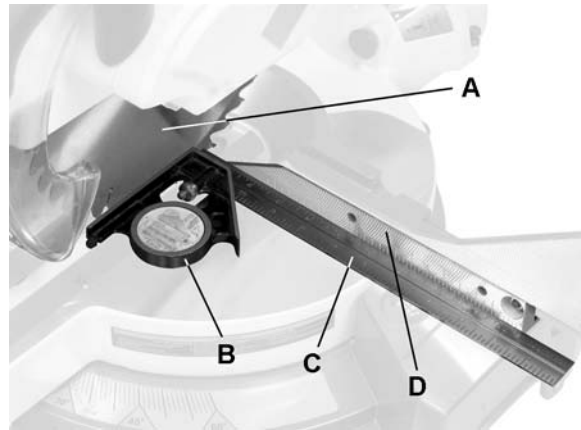

Figure 17

Positive Stop Miter Angle Adjustment

Referring to Figure 19:

1. Unlock the miter table by lifting up on the quick-cam *miter table lock* (A).
2. Raise the *positive stop locking lever* (C) up; at the same time grasp the *miter handle* (B) and rotate the miter table left or right to the desired angle.
3. Release the *positive stop locking lever* (C) and set the miter at the desired angle making sure the lever snaps into place.

Note: There are ten positive stops into which the lever will lock.

4. After the angle is selected, press down on the quick-cam *miter table lock* (A).

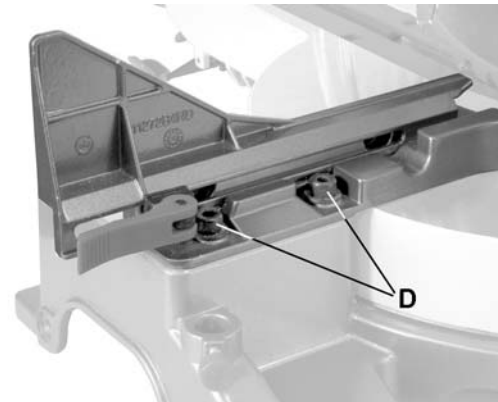

Figure 18

Quick-cam Miter Table Lock Operation

If a miter angle required is not one of ten positive stops, the miter table can be locked at any angle between these positive stops by using the quick-cam miter table lock.

Referring to Figure 19:

1. Unlock the miter table by lifting up on the quick-cam *miter table lock* (A).
2. Raise the *positive stop locking lever* (C) up; at the same time grasp the *miter handle* (B) and rotate the miter table left or right to the desired angle.
3. Release the positive stop locking lever (C).
4. Press down on the quick-cam *miter table lock* (A) until it locks the miter table in place.

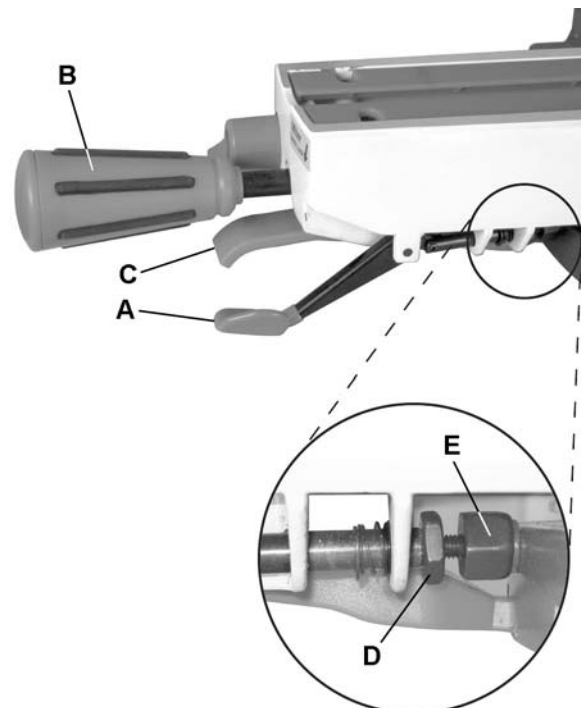

Figure 19

Note: The quick-cam miter table lock should lock the table and prevent it from moving. If adjustment is needed, see *Quick-cam Miter Table Lock Adjustment* below.

Quick-cam Miter Table Lock Adjustment

Referring to Figure 19:

1. Place the quick-cam *miter lock* (A) in the down position to lock.
2. Loosen the *lock nut* (D) with a 13 mm wrench, then turn the stop nut (E) to extend the locking arm against the base of the miter saw.
3. Test the quick-cam *miter lock* (A) to verify that it locks the table securely into position.
4. Tighten the *lock nut* (D) to lock the miter locking mechanism into place.

Presetting the Cutting Depth

The depth of cut can be preset for even and repetitive shallow cuts.

Referring to Figure 20:

1. Pull *hold-down latch* (C) out.
2. Flip the *stop plate* (A) counterclockwise to the left.
3. Adjust the cutting head down (See *Cutting Head* section) until the teeth of the blade are at the desired depth.
4. While maintaining the cutting head in the desired position, turn the *stop knob* (B) until it touches the *stop plate* (A).
5. Recheck the blade depth by moving the cutting head front to back through the full motion of a typical cut along the control arm.

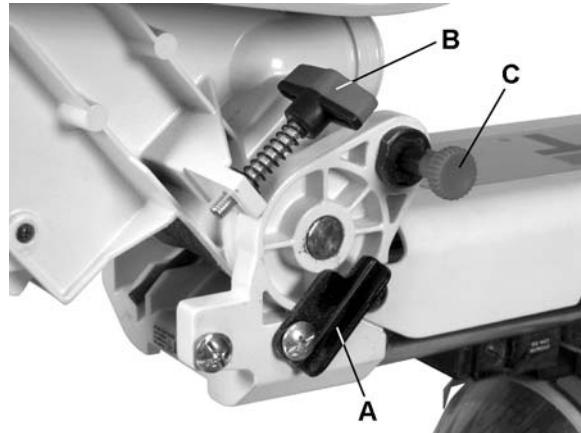

Figure 20

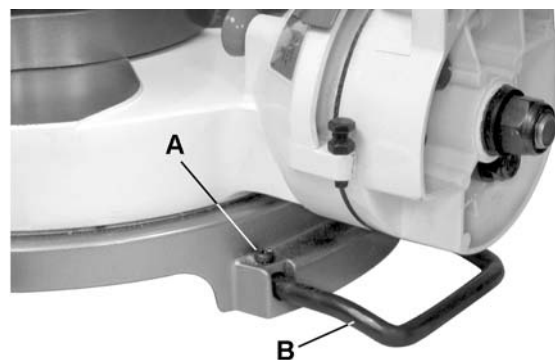

Figure 21

Rear Support Bar

⚠WARNING Do not operate the saw without the rear extension support bar. Failure to comply may result in serious injury!

Loosen the two screws (A, Fig. 21) and extend the rear extension support bar (B, Fig. 21) by sliding it out, then tighten the two screws.

Laser Beam

The laser is turned on with a switch located on the saw handle (A, Fig. 22). When left on indefinitely, a sensor will turn the laser off after 20 minutes. The switch must be reset (turned off, then turned on again after 2 seconds) to restart.

The laser has no adjustments and should not require adjustment. If adjustment should become necessary, take saw to an approved service center.

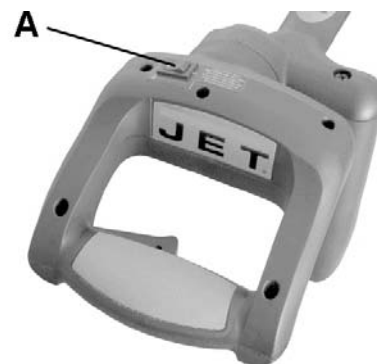
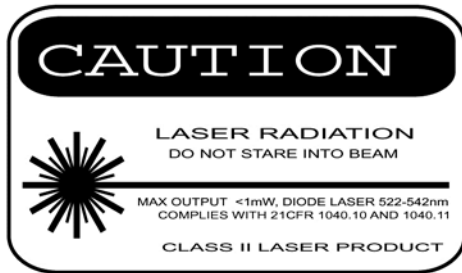

Figure 22

- **Laser radiation. Avoid direct eye exposure. Always un-plug miter saw from power source before making any adjustments.**
- **Laser Warning Label: Max output <1mW
DIODE LASER: 522-542nm, Complies with
21CFR 1040.10 and 1040. 11.**



CAUTION Use of controls or adjustments or performance of procedures other than those specified in this manual may result in hazardous radiation exposure.

CAUTION The use of optical instruments with this product will increase eye hazard.

- **Do not attempt to repair or disassemble the laser. If unqualified persons attempt to repair this laser product, serious injury may result. Any repair required on this laser product should be performed by authorized service center personnel.**

Operation

WARNING Before attempting any operation with your miter saw, make sure that you have read and thoroughly understand the warnings contained on pages 4-5 and the *Compound Miter Saw Safety* section on page 6. Failure to comply may result in serious injury!

Starting a cut

1. Place hands at least 8-3/4 in. away from the path of the blade.
2. Hold workpiece firmly against the fence to prevent movement toward the blade.
3. Bring the saw blade down to the workpiece to see the cutting path of the blade.
4. Squeeze the *trigger switch* (A, Fig. 23) to start saw.
5. Lower blade into workpiece with a firm downward motion.

Finishing a cut

1. Hold the cutting arm in the down position.
2. Release trigger switch (A, Fig. 23) and wait for all moving parts to stop before moving your hands and raising the cutting arm.
3. If the blade does not stop within 10 seconds, unplug the saw and follow the instructions in the *Troubleshooting* section.

If material becomes jammed

1. Release trigger switch.
2. Wait for all moving parts to stop.
3. Unplug the miter saw.

To Turn the Saw On

Depress the trigger switch (A, Fig. 23).

Note: Make the On/Off switch child-proof by inserting a padlock through the hole (B, Fig. 23) in the trigger switch.

The miter saw is equipped with an automatic blade brake. When the trigger switch is released, the electric blade brake will stop the blade within approximately 10 seconds.

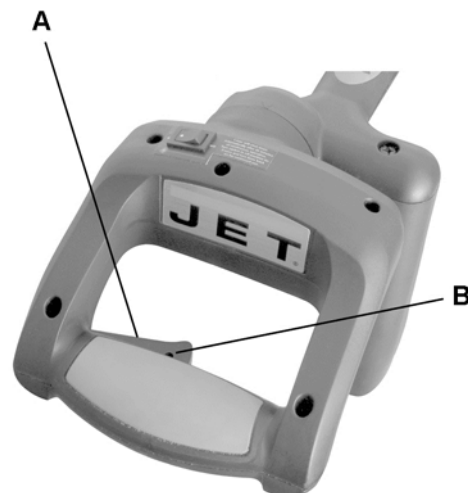

Figure 23

Sliding Fence

⚠WARNING The sliding fence must be extended to the left or right when making bevel cuts. Failure to comply may cause serious injury!

Failure to extend the sliding fence will not allow enough space for the blade to pass through. This could result in serious injury. At extreme miter or bevel angles the saw blade may also contact the fence resulting in damage to equipment as well as personal injury.

To adjust the sliding fence (refer to Figure 24):

1. Unlock the *fence cam locking lever* (A) (shown locked in Figure 24) by pushing it toward the rear of the machine.
2. Extend the *fence* (B) by sliding it out (C) to ensure that the blade will clear the fence for degree of the bevel cut selected. Lock the *fence cam locking lever* (A) as shown.

Note: Secure the sliding fence in position closest to the saw blade when transporting the saw.

Sliding Carriage System

⚠WARNING To reduce the risk of injury, return carriage to the full rear position after each crosscut operation.

- ❑ For chop cutting operations on small workpieces, slide the cutting head assembly completely toward the rear of the unit and tighten the *carriage lock knob* (A, Fig. 25).
- ❑ To cut wide boards up to 12 in., the *carriage lock knob* (A, Fig. 25) should be loosened to allow the cutting head to slide freely.

⚠WARNING To avoid injury from materials being thrown, always unplug the saw to avoid accidental starting, and remove small pieces of material from the table cavity. The table insert may be removed for this purpose, but always reattach the table insert prior to performing a cutting operation.

Miter Cut

Referring to Figure 26:

The sliding compound miter saw has ten positive miter stop detents (A) located on the saw base. The stops represent the following miter cut angles: 0, 15, 22.5, 31.6 and 45 degrees left and right, and 60° right. To make a miter cut:

1. Unlock the miter table by lifting up on the quick-cam *miter table lock* (E).

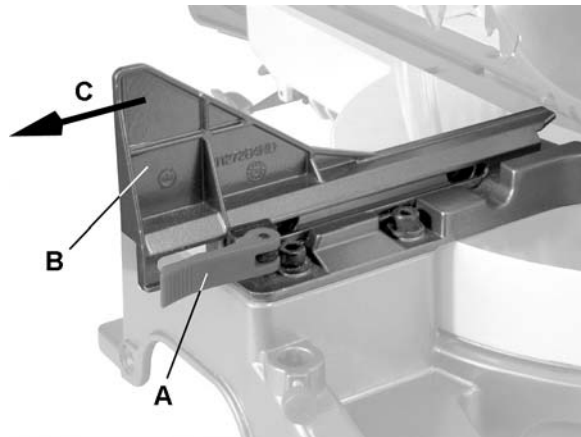

Figure 24



Figure 25

2. Raise the *positive stop locking lever* (C) up, at the same time grasp the *miter handle* (D) and rotate the miter table left or right to the desired angle.
3. Release the *positive stop locking lever* (C), making sure the lever snaps into place at one of the miter stop detents (A).

Note: The lever will only lock into place at one of the ten positive stops indicated above

Once the desired miter angle is achieved:

4. Press down on the quick cam *miter table lock* (E) to secure the table into position.

If the miter angle desired is *not* one of the ten positive stops noted above:

5. Simply lock the table at the desired angle by pressing down on the quick-cam *miter table lock* (E).

Bevel Cut

⚠WARNING The sliding fence must be extended to the left or right when making bevel cuts. Failure to comply may cause serious injury!

Failure to extend the sliding fence will not allow enough space for the blade to pass through. This could result in serious injury. At extreme miter or bevel angles the saw blade may also contact the fence resulting in damage to equipment as well as personal injury.

Tilt the cutting head to the desired angle as shown on the bevel scale. The blade can be positioned at any angle, from a 90° straight cut (0° on the scale) to a 45° left and right bevel. Tighten the *bevel lock handle* (B, Fig. 26) by pushing down to lock the cutting head in position. Bevel positive stops are provided at 0°, 33.9° and 45°.

Note: The saw comes with a 33.9° bevel detent pin for setting up crown molding cuts when the angle of the walls equals 90°.

33.9° Bevel Detent Pin for Crown Moldings

Note: A bevel detent pin is incorporated into this machine for quick bevel adjustments when the desired bevel angle is 33.9°.

Referring to Figure 27 (except where indicated):

1. Push the *bevel detent stop pin* (E) in.
2. Loosen the *bevel lock handle* (A).
3. Rotate the *cutting head* (D, Fig. 28) until the *bevel detent pin* (E) stops the bevel angle at 33.9° on the *bevel scale* (F).
4. Tighten the *bevel lock handle* (A) before you make your cut.

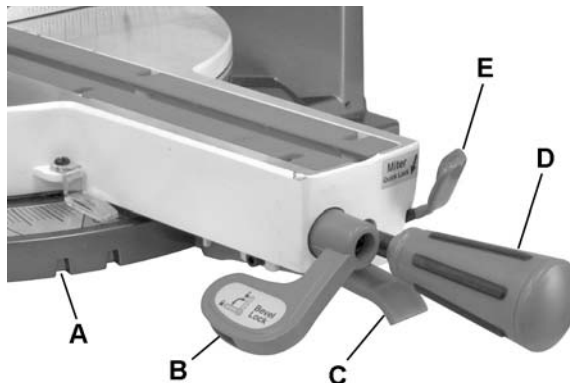

Figure 26

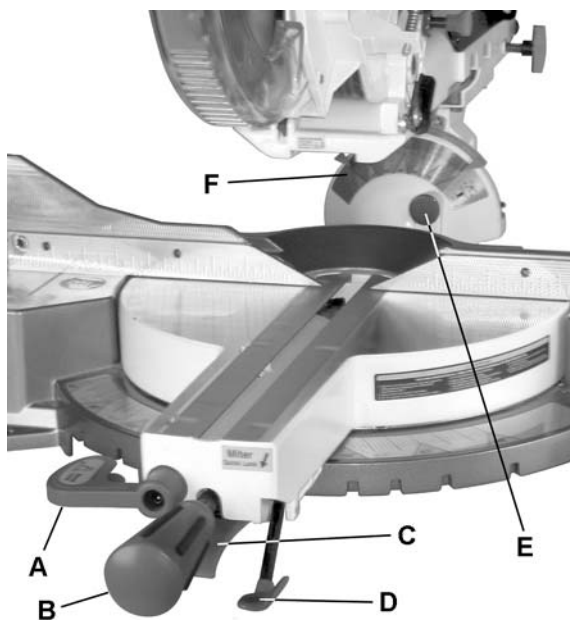

Figure 27

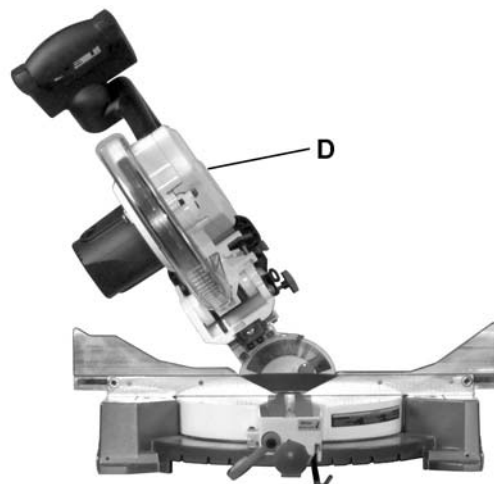

Figure 28

Compound Cuts

Referring to Figure 27:

Setting the bevel angle

1. Extend the fence by sliding it out to the required location (see *Sliding Fence* on page 22).
2. Loosen the *bevel lock handle* (A).
3. Set the desired bevel angle; then lock the *bevel lock handle* (A).

Setting the miter angle

4. Set the desired miter angle and lock into position. See *Miter Cut*.
5. Unlock the miter table by lifting up on the quick-cam *miter table lock* (D).
6. Raise the *positive stop locking lever* (C) up, at the same time grasp the *miter handle* (B) and rotate the miter table left or right to the desired angle.
7. Release the *positive stop locking lever* (C).
8. Lock the miter table by pressing down on the quick-cam *miter table lock* (D).

90° Crosscut – Narrow Boards

For 90° crosscut operations on small workpieces (refer to Figure 29):

1. Slide the cutting head assembly completely toward the rear of the unit and tighten the *carriage lock knob* (F).
2. Position the cutting head to the 0° bevel position and lock the *bevel lock handle* (C).
3. Position the table to the 0° miter angle and lock the quick cam *miter table lock* (D).
4. Position the workpiece on the table and against the fence. Use a *hold-down clamp* (E) attached to the base, whenever possible.
5. Pull the *trigger* (A), turning on the saw. Lower the blade by pushing the *handle* (B) down into the workpiece with slow and even pressure.
6. When the cut is complete, release the switch and allow the blade to stop before raising the cutting head assembly.

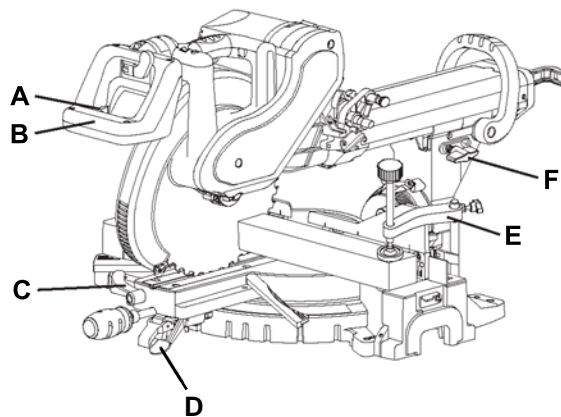

Figure 29

Slide Cutting Wide Boards

⚠WARNING Observe the following precautions:

- ❑ Never pull the cutting head assembly and spinning blade toward you during the cut.
- ❑ Let the blade reach full speed before cutting.
- ❑ Extending the fence by sliding it out to the required location.

Failure to comply may cause serious injury!

Use this operation to crosscut boards up to 12 inches wide.

Referring to Figure 30:

1. Unlock the *carriage lock knob* (D).
2. Set both the desired bevel angle and/or the miter angle as described in *Compound Cuts* (page 22); then lock into position.
3. If bevel cutting, set both the left and right sliding fences (C) to their proper location.
4. Use a hold down clamp to secure the workpiece.
5. Grasp the *switch handle* (F) and pull the *carriage* (A) forward until the center of the saw blade is over the front of the *workpiece* (B).
6. Pull the *trigger* (E) to turn the saw on.
7. When the saw reaches full speed, push the *saw handle* (F) down slowly, cutting through the leading edge of the workpiece.
8. Slowly move the *saw handle* (F) toward the *fence* (C) to complete the cut.
9. Release the *trigger* (E) and allow the blade to stop spinning before allowing the cutting head to raise.

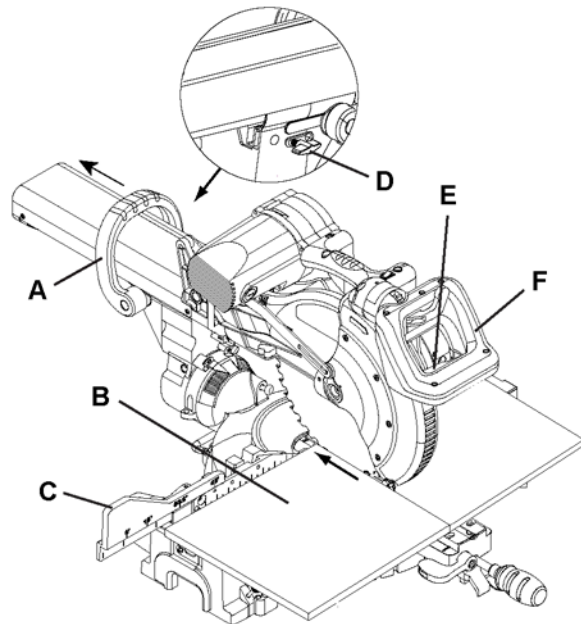

Figure 30

Cutting Bowed Material

⚠WARNING Always unplug the saw when removing small pieces of debris. Failure to comply may cause serious injury!

Referring to Figure 31:

1. Position a curved *workpiece* (C) against the *fence* (B).
2. Secure the curved workpiece with a *clamping device* (A).

Cutting a curved workpiece without the support of the fence and clamping device could result in personal injury.

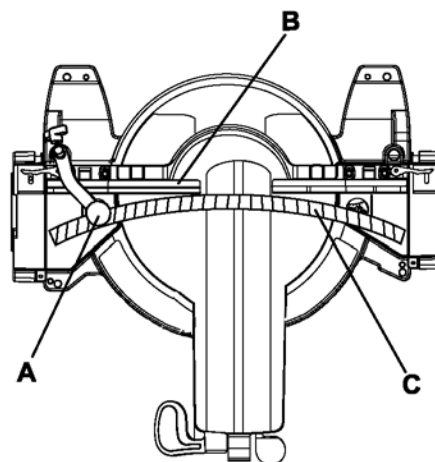

Figure 31

Rough Cutting a Dado

1. Mark lines identifying the width and depth of the desired cut on the workpiece and position on the table so the inside tip of the blade is positioned on the line. Use a hold down clamp to secure the workpiece.
2. Set the cutting depth as described in *Presetting the Cutting Depth* on page 18.
3. Lower the cutting head (the *hold-down latch C*, Fig. 32 must be in the *out* position as shown) so the tip of the blade touches the top surface workpiece at the marked line.
4. Cut two parallel grooves.

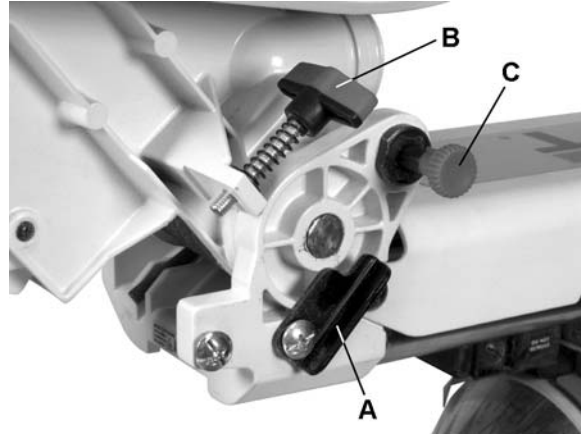

Figure 32

Auxiliary Wood Fence

When making multiple or repetitive cuts that result in cut-off pieces of one inch or less, it is possible for the saw blade to catch the cut-off piece and throw it out of the saw or into the blade guard and housing, possibly causing damage or injury. To minimize this, an auxiliary wood fence can be mounted to your saw. Holes are provided in the saw fence to attach an auxiliary wood fence (this provides additional depth of cut). This fence should be constructed of straight wood approximately 3/4 in. thick by 1-1/2 in. high by 22 in. long. Attach the wood fence securely and make a full depth cut to make a blade slot. Check for interference between the wood fence and the lower blade guard. Adjust if necessary.

Cutting Base Molding

Base moldings and many other moldings can be cut on a compound miter saw. The setup of the saw depends on molding characteristics and application. Perform practice cuts on scrap material to achieve best results:

1. Always make sure moldings rest firmly against fence and table. Use hold-down, crown molding vise or C-clamps, whenever possible, and place tape on the area being clamped to avoid marks.
2. Reduce splintering by taping the cut area prior to making the cut. Mark the cut line directly on the tape.
3. Splintering typically happens due to an incorrect blade application and thinness of the material.

Note: Always perform a dry run cut so you can determine if the operation being attempted is possible before power is applied to the saw.

Crown Molding

Your compound miter saw is suited for the difficult task of cutting crown molding. To fit properly, crown molding must be compound-mitered with extreme accuracy. The two surfaces on a piece of crown molding that fit flat against the ceiling and wall are at angles that, *when added together, equal exactly 90°*.

Most crown molding has a top rear angle (the section that fits flat against the ceiling) of 52° and a bottom rear angle (the section that fits flat against the wall) of 38°.

In order to accurately cut crown molding for a 90° inside or outside corner, lay the molding with its broad back surface flat on the saw table.

When setting the bevel and miter angles for compound miters, remember that the settings are interdependent; changing one changes the other, as well.

Changing the Belt

1. Unplug your saw.
2. Loosen the bolts and remove the belt cover.
3. Turn the screw counterclockwise with a hex wrench to move the motor forward.
4. Remove and replace the belt.
5. Turn the screw clockwise with a hex wrench to move the motor back. Do not over tighten.
6. Replace the belt cover and tighten the bolts.

Bevel/Miter Settings

Settings for standard crown molding lying flat on compound miter saw table.

Note: The chart below references a compound cut for crown molding *only when the angle between the walls equals 90°*.

Type of Cut	Key	Bevel Setting	Miter Setting	Procedure
Inside corner – Left Side	IL	33.9°	31.6° Right	<ol style="list-style-type: none"> 1. Position top of molding against fence. 2. Miter table set at RIGHT 31.6°. 3. LEFT side is finished piece.
Inside corner – Right Side	IR	33.9°	31.6° Left	<ol style="list-style-type: none"> 1. Position bottom of molding against fence. 2. Miter table set at LEFT 31.6°. 3. LEFT side is finished piece.
Outside corner – Left Side	OL	33.9°	31.6° Left	<ol style="list-style-type: none"> 1. Position bottom of molding against fence. 2. Miter table set at LEFT 31.6°. 3. RIGHT side is finished piece.
Outside corner – Right Side	OR	33.9°	31.6° Right	<ol style="list-style-type: none"> 1. Position top of molding against fence. 2. Miter table set at RIGHT 31.6°. 3. RIGHT side is finished piece

Crown Molding Chart

Compound miter saw *miter and bevel angle settings, wall to crown molding angles*

Angle Between Walls	52/38° Crown Molding		45/45° Crown Molding	
	Miter Setting	Bevel Setting	Miter Setting	Bevel Setting
67	42.93	41.08	46.89	36.13
68	42.39	40.79	46.35	35.89
69	41.85	40.50	45.81	35.64
70	41.32	40.20	45.28	35.40
71	40.79	39.90	44.75	35.15
72	40.28	39.61	44.22	34.89
73	39.76	39.30	43.70	34.64
74	39.25	39.00	43.18	35.38
75	38.74	38.69	42.66	34.12
76	38.24	38.39	42.15	33.86
77	37.74	38.08	41.64	33.60
78	37.24	37.76	41.13	33.33
79	36.75	37.45	40.62	33.07
80	36.27	37.13	40.12	32.80
81	35.79	36.81	39.62	32.53
82	35.31	36.49	39.13	32.25
83	34.83	36.17	38.63	31.98
84	34.36	35.85	38.14	31.70
85	33.90	35.52	37.66	31.42
86	33.43	35.19	37.17	31.34
87	32.97	34.86	36.69	30.86
88	32.52	34.53	36.21	30.57
89	32.07	34.20	35.74	30.29
90	31.62	33.86	35.26	30.00
91	31.17	33.53	34.79	29.71
92	30.73	33.19	34.33	29.42
93	30.30	32.86	33.86	29.13
94	29.86	32.51	33.40	28.83
95	29.43	32.17	32.94	28.54
96	29.00	31.82	32.48	28.24
97	28.58	31.48	32.02	27.94
98	28.16	31.13	31.58	27.64
99	27.74	30.78	31.13	27.34
100	27.32	30.43	30.68	27.03
101	26.91	30.08	30.24	26.73
102	26.50	29.73	29.80	26.42
103	26.09	29.38	29.36	26.12
104	25.69	29.02	28.92	25.81
105	25.29	28.67	28.48	25.50
106	24.89	28.31	28.05	25.19
107	24.49	27.96	27.62	24.87
108	24.10	27.59	27.19	24.56
109	23.71	27.23	26.77	24.24
110	23.32	26.87	26.34	23.93
111	22.93	26.51	25.92	23.61
112	22.55	26.15	25.50	23.29
113	22.17	25.78	25.08	22.97
114	21.79	25.42	24.66	22.66
115	21.42	25.05	24.25	22.33
116	21.04	24.68	23.84	22.01
117	20.67	24.31	23.43	21.68
118	20.30	23.94	23.02	21.36
119	19.93	23.57	22.61	21.03
120	19.57	23.20	22.21	20.70
121	19.20	22.83	21.80	20.38
122	18.84	22.46	21.40	20.05
123	18.48	22.09	21.00	19.72

Angle Between Walls	52/38° Crown Molding		45/45° Crown Molding	
	Miter Setting	Bevel Setting	Miter Setting	Bevel Setting
124	18.13	21.71	20.61	19.39
125	17.77	21.34	20.21	19.06
126	17.42	20.96	19.81	18.72
127	17.06	20.59	19.42	18.39
128	16.71	20.21	19.03	18.06
129	16.37	19.83	18.64	17.72
130	16.02	19.45	18.25	17.39
131	15.67	19.07	17.86	17.05
132	15.33	18.69	17.48	16.71
133	14.99	18.31	17.09	16.38
134	14.66	17.93	16.71	16.04
135	14.30	17.55	16.32	15.70
136	13.97	17.17	15.94	15.36
137	13.63	16.79	15.56	15.02
138	13.30	16.40	15.19	14.62
139	12.96	16.02	14.81	14.34
140	12.63	15.64	14.43	14.00
141	12.30	15.25	14.06	13.65
142	11.97	14.87	13.68	13.31
143	11.64	14.48	13.31	12.97
144	11.31	14.09	12.94	12.62
145	10.99	13.71	12.57	12.29
146	10.66	13.32	12.20	11.93
147	10.34	12.93	11.83	11.59
148	10.01	12.54	11.46	11.24
149	9.69	12.16	11.09	10.89
150	9.37	11.77	10.73	10.55
151	9.05	11.38	10.36	10.20
152	8.73	10.99	10.00	9.85
153	8.41	10.60	9.63	9.50
154	8.09	10.21	9.27	9.15
155	7.77	9.82	8.91	8.80
156	7.46	9.43	8.55	8.45
157	7.14	9.04	8.19	8.10
158	6.82	8.65	7.83	7.75
159	6.51	8.26	7.47	7.40
160	6.20	7.86	7.11	7.05
161	5.88	7.47	6.75	6.70
162	5.57	7.08	6.39	6.35
163	5.26	6.69	6.03	6.00
164	4.95	6.30	5.68	5.65
165	4.63	5.90	5.32	5.30
166	4.32	5.51	4.96	4.94
167	4.01	5.12	4.61	4.59
168	3.70	4.72	4.25	4.24
169	3.39	4.33	3.90	3.89
170	3.08	3.94	3.54	3.53
171	2.77	3.54	3.19	3.10
172	2.47	3.15	2.83	2.83
173	2.15	2.75	2.48	2.47
174	1.85	2.36	2.12	2.12
175	1.54	1.97	1.77	1.77
176	1.23	1.58	1.41	1.41
177	0.92	1.18	1.06	1.06
178	0.62	0.79	0.71	0.71
179	0.31	0.39	0.35	0.35

Maintenance

▲WARNING To avoid injury while performing maintenance, always unplug the power cord before working on the saw. Failure to comply may cause serious injury!

▲WARNING Never use gasoline or any highly volatile solvents to clean the miter saw. Failure to comply may cause serious injury!

▲WARNING Use only replacement parts that are identical to the parts list at the end of this manual and reassemble exactly as the original assembly to avoid electrical shock. Failure to comply may cause serious injury!

Replacing Carbon Brushes

Replace both carbon brushes when either has less than 1/4 in. length of carbon remaining, or if the spring or wire is damaged or burned.

To inspect or replace brushes:

1. Unplug the saw.
2. Remove the black plastic cap on the side of the motor
Remove the cap cautiously, because it is spring-loaded.
3. Pull out the brush and replace.
4. Reverse above steps to reassemble. Tighten the cap snugly, but do not over-tighten.

Replace the brush for the other side in the same manner described above.

Note: To reinstall the same brushes, first make sure the brushes go back in the way they came out. This will avoid a break-in period that reduces motor performance and increases wear.

Lower Blade Guard

Do not use the saw without the lower blade guard. The lower blade guard is attached to the saw for your protection. Should the lower guard become damaged, do not use the saw until the damaged guard has been replaced. Develop a regular check to make sure the lower guard is working properly. Clean the lower guard of any dust or buildup with a damp cloth.

▲WARNING When cleaning the lower guard, unplug the saw from the power source receptacle to avoid unexpected startup.

▲WARNING Do not use solvents on the guard. They could make the plastic “cloudy” and brittle.

Saw Dust

Periodically, saw dust will accumulate under the work table and base. This could cause difficulty in the movement of the worktable when setting up a miter cut. Frequently blow out or vacuum up the saw dust.

▲WARNING If blowing saw dust, wear proper eye protection to keep debris from entering eyes.

Lubrication

All the motor bearings in this tool are lubricated with a sufficient amount of high grade lubricant for the life of the unit under normal operating conditions; therefore, no further lubrication is required.

Lubricate the following as necessary:

Chop pivot: Apply light machine oil.

Central pivot of plastic guard: Use light household oil (sewing machine oil) on metal-to-metal or metal-to-plastic guard contact areas as required for smooth, quiet operation. Avoid excessive oil, to which saw dust will cling.

Troubleshooting – Motor

Trouble	Probable Cause	Remedy
Brake does not stop blade within 10 seconds.	<p>Motor brushes not sealed or lightly sticking.</p> <p>Motor brake overheated from use of defective or wrong size blade or rapid ON/OFF cycling.</p> <p>Arbor bolt loose.</p> <p>Brushes cracked, damaged, etc.</p> <p>Other.</p>	<p>Inspect/clean/replace brushes.</p> <p>See <i>Maintenance</i> section.</p> <p>Use a recommended blade. Let cool down. See <i>Removing or Installing the Blade</i> section.</p> <p>Retighten. See <i>Removing or Installing the Blade</i> section.</p> <p>Replace brushes.</p> <p>Contact your Service Center.</p>
Motor does not start	<p>Limit switch failure</p> <p>Brush worn.</p> <p>Fuse blown or circuit breaker tripped on home panel.</p>	<p>Replace limit switch.</p> <p>Replace brushes. See <i>Maintenance</i> section.</p> <p>Verify there is electrical power at the outlet.</p>
Brush spark when switch released.	<p>Worn brush.</p> <p>Other.</p>	<p>Replace brushes. See <i>Maintenance</i> section.</p> <p>Contact your Service Center.</p>

Troubleshooting – Operation

Trouble	Probable Cause	Remedy
Blade hits table.	Misalignment.	See the Setting Cutting Depth section in Adjustments
Angle of cut not accurate. Cannot adjust miter.	<p>Miter table unlocked.</p> <p>Saw dust under table.</p>	<p>See the Miter Angle Adjustment section in Operations</p> <p>Vacuum or blow out dust.</p> <p>Important: Wear eye protection.</p>
Cutting arm wobbles.	Loose pivot points.	Contact Service Center.
Cutting arm will not fully raise, or blade guard won't fully close.	<p>Pivot spring not replaced properly after service.</p> <p>Saw dust build-up.</p>	<p>Contact Service Center.</p> <p>Clean and lubricate moving parts.</p>
Blade binds, jams, burns wood.	<p>Improper operation.</p> <p>Dull or warped blade.</p> <p>Improper blade size.</p> <p>Wood is moving during cut.</p>	<p>See Operations section.</p> <p>Replace or sharpen blade.</p> <p>Replace with 10-in. diameter blade.</p> <p>Use hold down clamp to secure workpiece to table.</p>
Saw vibrates or shakes.	<p>Saw blade not round / damaged / loose.</p> <p>Arbor bolt loose.</p>	<p>Replace blade.</p> <p>Tighten arbor bolt.</p>
Laser not aligned		Contact Service Center.
Laser turns off	Laser turns off after 20 minutes to prevent heat buildup.	Reset laser switch on trigger handle (turn off, after 2 seconds turn on again).

Parts

Ordering Replacement Parts

To order parts or reach our service department, call 1-800-274-6848 Monday through Friday (see our website for business hours, www.jettools.com). Having the Model Number and Serial Number of your machine available when you call will allow us to serve you quickly and accurately.

Parts List

Note: Parts without part numbers are for reference only and cannot be purchased individually.

Index No.	Part No.	Description	Size	Qty
1	JMS10SCMS-1	Shaft Sleeve		1
2	JMS10SCMS-2	Knob		1
3	JMS10SCMS-3	Locator Pin		1
4	JMS10SCMS-4	Label: Miter Quick Lock		1
5	JMS10SCMS-5	Compression Spring		1
6	JMS10SCMS-6	Cushion		2
7		Lock Screw		2
8	JMS10SCMS-8	Nut		1
9		Link		1
10	JMS10SCMS-10	Cord Clamp		1
11	JMS10SCMS-11	Warning Label		1
12	JMS10SCMS-12	Compression Spring		1
13	JMS10SCMS-13	Bumper		1
14	JMS10SCMS-14	Knob		1
15	JMS10SCMS-15	Collar		1
16	JMS10SCMS-16	Guard Spring		1
17	JMS10SCMS-17	Center Bolt		1
18	JMS10SCMS-18	Arbor Collar		2
19	JMS10SCMS-19	Blade Wrench		1
20	JMS12SCMS-27	Power Cord Clamp		1
21	JMS10SCMS-21	Pin		1
23		Ball Bearing	6003LLU	1
24		Ball Bearing	607ZZ	1
25		Ball Bearing	608ZZ	1
26		Ball Bearing	6001ZZ	1
27	TS-1550031	Flat Washer	M5	1
28	TS-1550041	Flat Washer	M6	2
29	TS-155010	Flat Washer	M16	2
30	TS-1550041	Flat Washer	M6	2
31	JMS10SCMS-31	Flat Washer	8x16x2.5	1
32	JMS10SCMS-32	Flat Washer	1/4x7/16x1/16	4
33	JMS10SCMS-33	Flat Washer	1/4x1/2x3/32	1
34	JMS10SCMS-34	Flat Washer	1/4x5/8x3/32	1
35	TS-0680041	Flat Washer	3/8	1
36	JMS10SCMS-36	External Tooth Lock Washer	M5	2
37	JMS10SCMS-37	Wave Washer	WW-8	2
38		Spring Pin	Ø5x16	4
39		Spring Pin	Ø2.5x8	2
40		C-Ring	A-12	1
41	JMS10SCMS-41	E-Clip	E-6	1
42	JMS10SCMS-42	O-Ring	P10	1
43	JMS10SCMS-43	O-Ring	P7	1
45	TS-1482051	Hex Cap Screw	M6x25	2
46	TS-1490081	Hex Cap Screw	M8x45	1
47	TS-1503041	Socket Head Cap Screw	M6x16	3

Parts List

Index No.	Part No.	Description	Size	Qty
48	TS-1504031	Socket Head Cap Screw	M8x16	1
49	TS-1504061	Socket Head Cap Screw	M8x30	2
50	TS-1504121	Socket Head Cap Screw	M8x60	1
52	TS-1524041	Socket Set Screw	M8x16	1
53	TS-1523031	Socket Set Screw	M6x10	2
54	JMS10SCMS-54	Arbor Bolt		1
55	JMS10SCMS-55	Socket Head Cap Screw with Lock Washer	M6x16	1
56	JMS10SCMS-56	Socket Head Cap Screw with Washer	M8x25	4
57	JMS10SCMS-57	Hex Socket Truss Head Screw w/Lock Washer	M6x16	4
58	TS-1534051	Flat Head Screw	M6x16	1
59	JMS10SCMS-59	Truss Head Screw	M5x8	2
60	JMS10SCMS-60	Truss Head Screw	M6x8	4
61	JMS10SCMS-61	Round Washer Head Screw	M5x12	1
62	JMS10SCMS-62	Truss Head Round Neck Screw	M6x18	1
63	JMS10SCMS-63	Truss Head Round Neck Screw	M6x10	2
64	JMS10SCMS-64	Truss Head Round Neck Screw	M6x14	1
65	JMS10SCMS-65	Pan Head Tapping Screw	M3-24x10	2
66	TS-2284082	Pan Head Screw	M4x8	7
67	JMS10SCMS-72	Pan Head Screw	M5x8	2
68	JMS10SCMS-68	Pan Head Tapping Screw	M5-16x25	1
69	JMS10SCMS-69	Pan Head Tapping Screw	M4-18x25	5
70	JMS10SCMS-70	Truss Head Tapping Screw	M4-16x12	1
71	TS-1532052	Pan Head Screw	M4x16	4
72	JMS10SCMS-72	Pan Head Screw	M5x8	3
73	TS-1533062	Pan Head Screw	M5x20	1
74		Pan Head Screw	M5x10	4
75	JMS10SCMS-75	Pan Head Screw	M6x8	2
76	TS-1534052	Pan Head Screw	M6x16	3
77	JMS10SCMS-77	Pan Head Round Neck Screw	M4x7.5	2
78	JMS10SCMS-78	Pan Head Round Neck Screw	M6x12	1
79		Rivet	Ø4x6.35	5
81	TS-1541011	Nylon Insert Lock Nut	M5	1
82	TS-1541021	Nylon Insert Lock Nut	M6	4
83	TS-1541031	Nylon Insert Lock Nut	M8	2
84	TS-2342161	Nylon Insert Lock Nut	M16	1
85	JMS10SCMS-85	Strain Relief		1
86	JMS10SCMS-86	Cable Clamp	1/2"	2
88	JMS10SCMS-88	Terminal		2
89	TS-1541041	Nylon Insert Lock Nut	M10	1
90	JMS10SCMS-90	Dust Bag		1
91	TS-1540041	Hex Nut	M6	2
92	JMS10SCMS-92	Washer	M8x23x1.5	1
93	JMS10SCMS-93	Label: Rotation		1
94		Pin	Ø5x16	2
95	JMS10SCMS-95	Knob		2
96	JMS10SCMS-96	Stop Screw		1
97	JMS10SCMS-97	Bevel Lock Handle		1
98	JMS10SCMS-98	Pointer		1
99	JMS10SCMS-99	Disc		1
100	JMS10SCMS-100	Anchor Plate		1
101	JMS10SCMS-101	Pulley		1
102	JMS10SCMS-102	Power Cord		1
103	JMS10SCMS-103	Warning Label: Avoid Exposure		1
104	JMS10SCMS-104	Bushing		1
105	JMS10SCMS-105	Locking Rod		1

Parts List

Index No.	Part No.	Description	Size	Qty
106		Slide Bar, Right		1
107		Slide Bar, Left		1
108	JMS10SCMS-108	Pivot Shaft		1
109	JMS10SCMS-109	Label: Bevel Lock		1
110	JMS10SCMS-110	Table Insert, Right		1
111	JMS10SCMS-111	Table Insert, Left		1
112		Collar		1
113		Shaft		1
114	JMS10SCMS-114	Set Nut		1
115	JMS10SCMS-115	Screw Stop		1
116	JMS10SCMS-116	Lock Knob		1
117	JMS10SCMS-117	Lock Knob		1
118	JMS10SCMS-118	Anchor Plate		1
119	JMS10SCMS-119	Compression Spring		1
120	JMS10SCMS-120	Pin	Ø4x22	1
121	JMS10SCMS-121	Compression Spring		1
122	TS-1523051	Socket Set Screw	M6x16	2
124	JMS10SCMS-124	SHCS with Lock Washer & Flat Washer	M5x12	4
125		Helix Gear		1
126	JMS10SCMS-126	Base		1
127	JMS10SCMS-127	Fence		1
128	JMS10SCMS-128	Fence Extension, Left		1
129	JMS10SCMS-129	Fence Extension, Right		1
130	JMS10SCMS-130	Slide Plate		3
131		Lock Handle		1
132	JMS10SCMS-132	Table		1
133	JMS10SCMS-133	Pointer, Left		1
134	JMS10SCMS-134	Pointer, Right		1
136	JMS10SCMS-136	Handle		1
137		Pivot Support		1
138		Rear Slide Bar Seat		1
139		Arbor		1
140		Bracing Plate		1
141	JMS10SCMS-141	Guard Plate		1
142		Blade Guard		1
143	JMS10SCMS-143	Gear Box Cover		1
144	JMS10SCMS-144	Lever		1
145	JMS10SCMS-145	Saw Arm		1
146	JMS10SCMS-146	Hex Cap Screw (LH Threads)	M6x16	1
147	JMS10SCMS-147	SHCS with Lock Washer & Flat Washer	M5x40	1
148	JMS10SCMS-148	Upper Handle Segment		1
149	JMS10SCMS-149	Lower Handle Segment		1
150	JMS10SCMS-150	Collar		1
151	JMS10SCMS-151	Plate		2
152		Gear Shaft		1
153	JMS10SCMS-153	Torsion Spring		1
154		Bearing Protector		1
155	JMS10SCMS-155	Washer		4
156	JMS10SCMS-156	V-Ribbed Belt	195J8	1
157	JMS10SCMS-157	Pivot Shaft		1
158	JMS10SCMS-158	Locating Bar		1
159	JMS10SCMS-159	Linear Motion Bearing	LM30LLU	1
160	JMS10SCMS-160	Blade Guard Assembly		1
161	JMS10SCMS-161	Locking Handle Assembly		1
162	JMS10SCMS-162	Slotted Set Screw	M6x8	4
163	JMS10SCMS-163	Gasket		1

Parts List

Index No.	Part No.	Description	Size	Qty
164	JMS10SCMS-164	Compression Spring		1
165	JMS10SCMS-165	Truss Head Screw	M3x12	1
166		Key	4x4x8	1
167	JMS10SCMS-167	Gear Shaft Assembly		1
168	JMS10SCMS-168	Arbor Assembly		1
169	JMS10SCMS-169	Base Rear Extension		1
170	JMS10SCMS-170	Rocker Switch		1
171	JMS10SCMS-171	Warning Label		1
172	JMS10SCMS-172	Label: Do Not Remove		2
173	JMS10SCMS-173	Insulator		1
174	JMS10SCMS-174	Rivet		2
175	JMS10SCMS-175	Locking Knob		1
176	JMS10SCMS-176	Upper Handle		1
177	JMS10SCMS-177	Lower Handle		1
178	JMS10SCMS-178	Laser Housing		1
179	JMS10SCMS-179	Slide Bar Guard		1
180	JMS10SCMS-180	Pulley Cover		1
181	JMS10SCMS-181	Locking Handle Assembly		1
182	JMS10SCMS-182	Release Lever		1
183	JMS10SCMS-183	Clear Panel		1
184	JMS10SCMS-184	Locking Handle Assembly		2
185		Lock Handle		2
186	JMS10SCMS-186	Guard Plate		2
187	JMS10SCMS-187	Green Laser Controller Assembly		1
188	JMS10SCMS-188	Green Laser		1
190	JMS10SCMS-190	Slide Bar Assembly		1
191	JMS10SCMS-191	Motor		1
	JMS10SCMS-191MB	Motor Brush (not shown)		2
	JMS10SCMS-191MBC	Motor Brush Cover (not shown)		2
192	JMS10SCMS-192	Saw Blade	10"x40Tx5/8" Arbor	1
193	JMS10SCMS-193	Guard		1
194	JMS10SCMS-194	Clamp Hold Down Assembly		1
195	JMS10SCMS-195	Lead Wire		1
196	JMS10SCMS-196	Laser Housing Bracket		1
198	JMS10SCMS-198	Label: Laser Caution		1
199	JMS10SCMS-199	JET Label for Pulley Cover		1
200	JMS10SCMS-200	Label: Laser On/Off		1
201	JMS10SCMS-201	JET Label for Slide Bar Guard		1
202	JMS10SCMS-202	JET Label		1
203	JMS10SCMS-203	ID Label		1
204	JMS10SCMS-204	JET Label for Handle		1
205	JMS10SCMS-205	Bevel Angle Scale		1
206	TS-0680041	Flat Washer	3/8	1
207	JMS10SCMS-207	Special Bolt		1
208	JMS10SCMS-208	Trigger Switch		1
209	JMS10SCMS-209	Miter Angle Scale		1
210	JMS10SCMS-210	Cable Clamp	1/8"	1
211	JBTS10MJS-70	Pan Head Tapping Screw	M3-24x6	1
212	JMS10SCMS-212	O-Ring	30x3.5	2
213	TS-1502051	Socket Head Cap Screw	M5x20	4
214	JMS10SCMS-214	Cover Plate		1
215	JMS10SCMS-215	Cover Plate		1
216	JMS10SCMS-216	Slide/Bevel Arm		1
217	JMS10SCMS-217	Collar		1
218	JMS10SCMS-218	Linear Motion Bearing	LM30SUU	1

Assembly Drawing

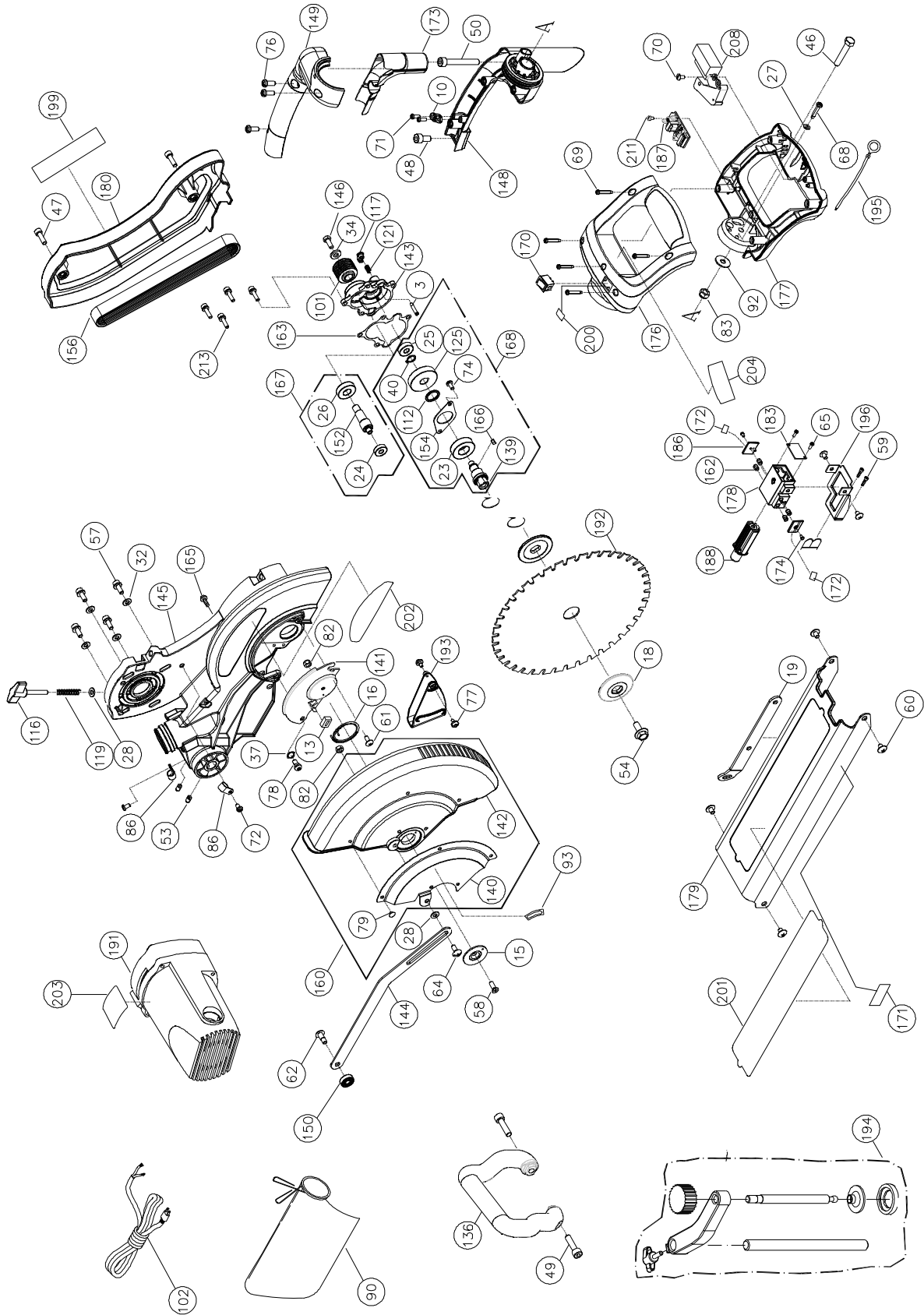

Assembly Drawing

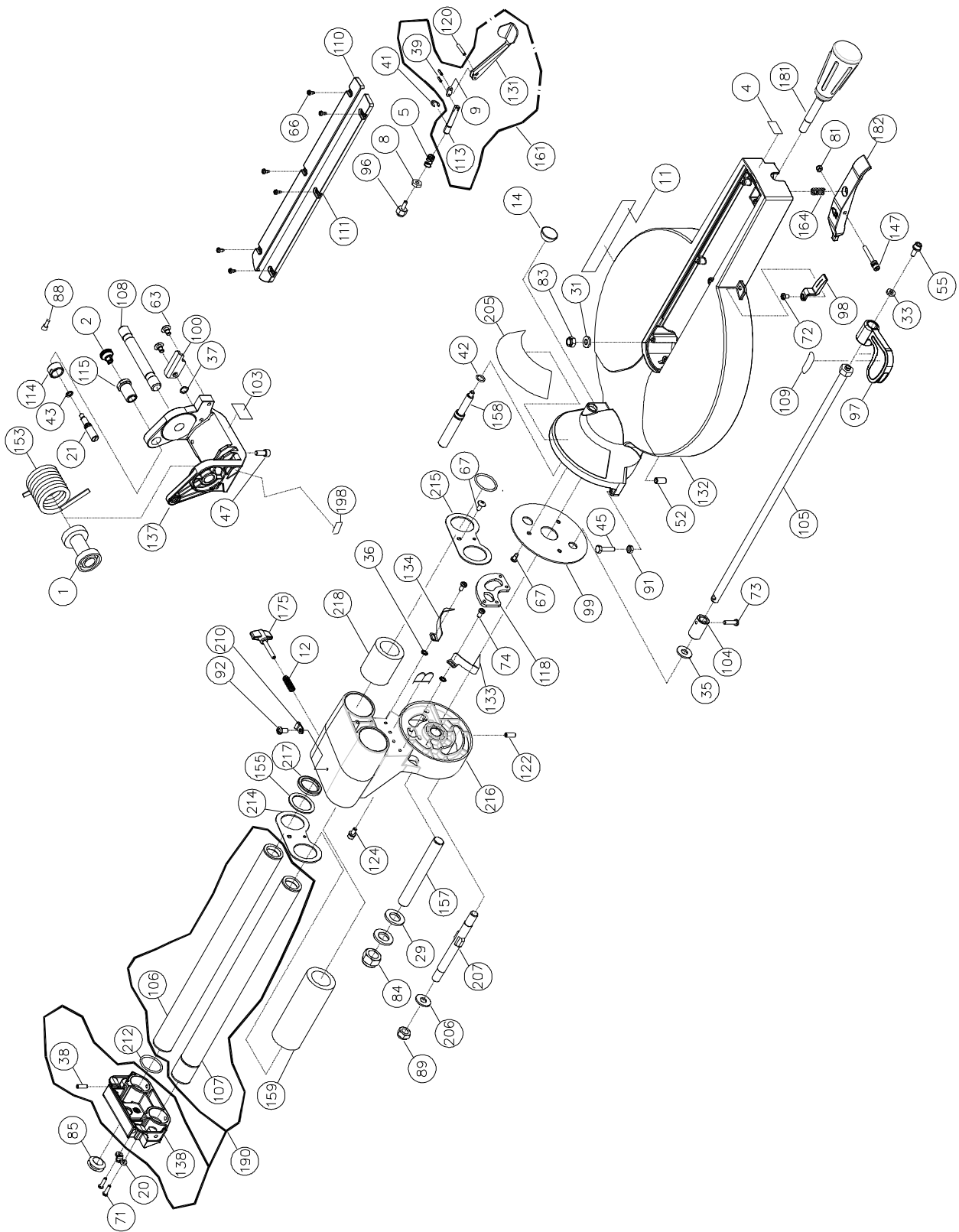

Assembly Drawing

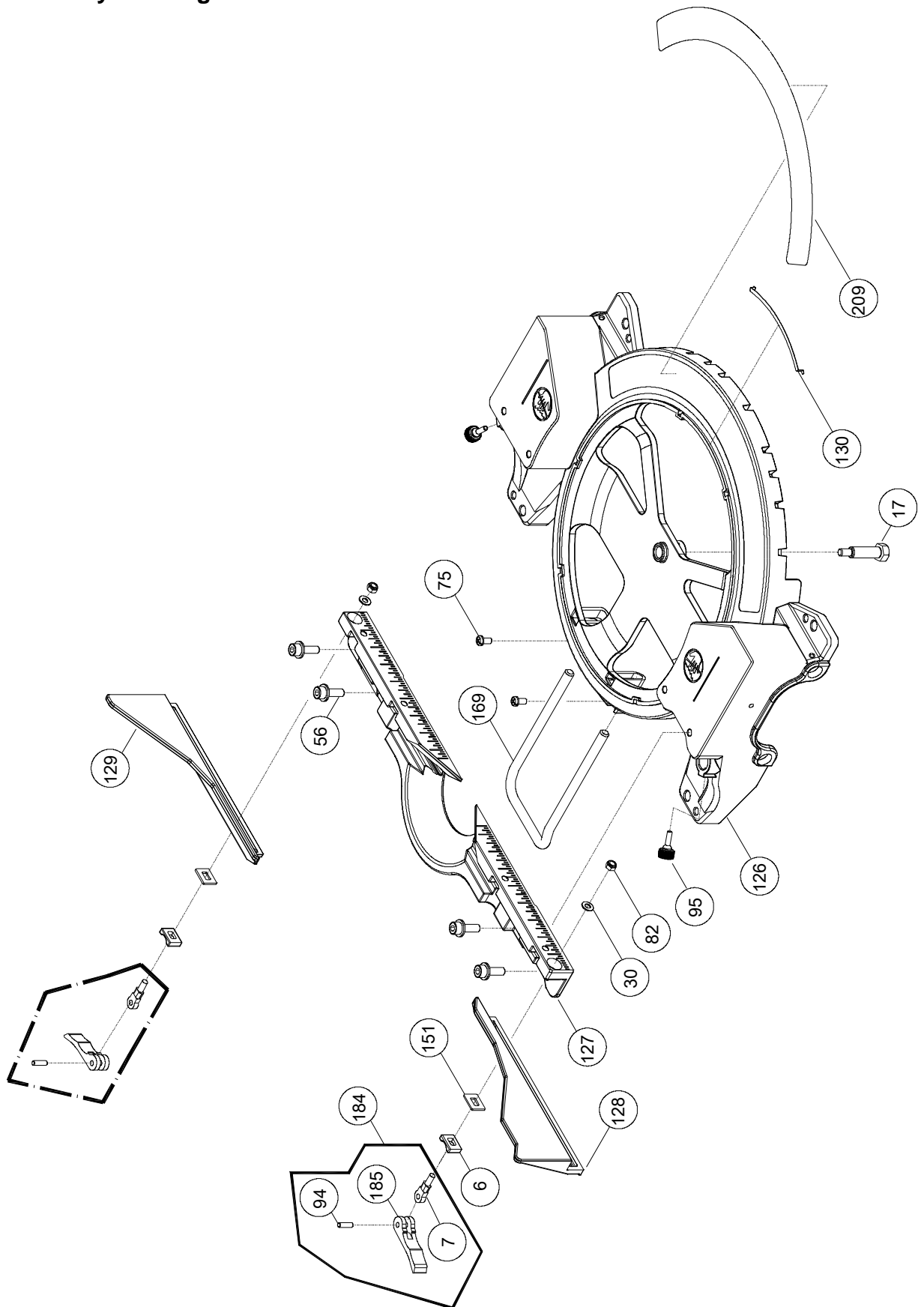

Wiring Diagram

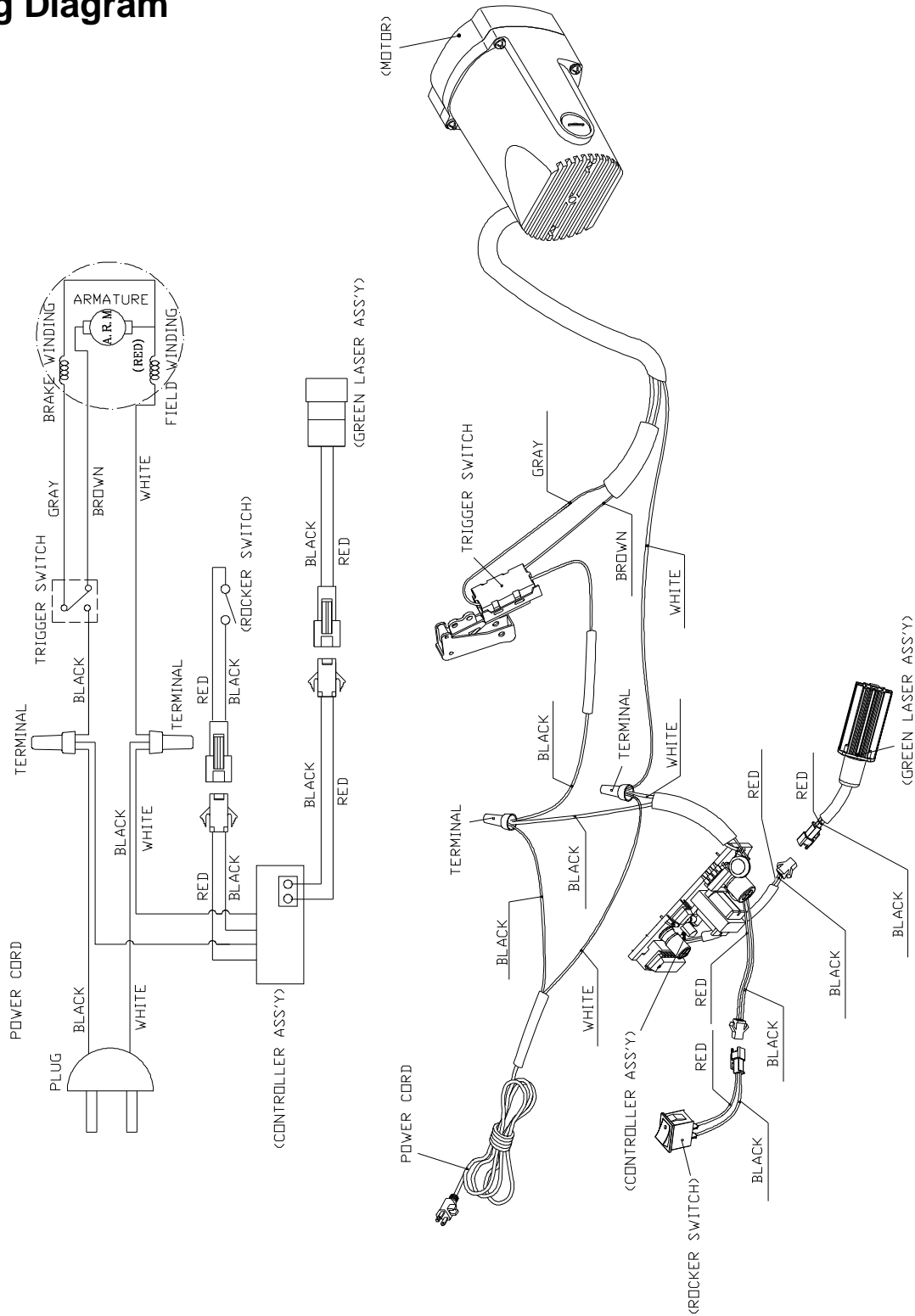

JET

427 New Sanford Road
 LaVergne, Tennessee 37086
 Phone: 800-274-6848
www.jettools.com