



Model No.:	Stock No.:
Serial No.:	
Purchased From:	
Date Purchased:	Date Installed:

Operating Instructions and Parts Manual Electronic Variable Speed Turret Mill

Model JTM-1050EVS



JET
427 New Sanford Road
LaVergne, Tennessee 37086
Ph.: 800-274-6848
www.jettools.com

Part No. M-690060
Revision G1 06/2015
Copyright © 2015 JET

1.0 Warranty and Service

JET® warrants every product it sells against manufacturers' defects. If one of our tools needs service or repair, please contact Technical Service by calling 1-800-274-6846, 8AM to 5PM CST, Monday through Friday.

Warranty Period

The general warranty lasts for the time period specified in the literature included with your product or on the official JET branded website.

- JET products carry a limited warranty which varies in duration based upon the product. (See chart below)
- Accessories carry a limited warranty of one year from the date of receipt.
- Consumable items are defined as expendable parts or accessories expected to become inoperable within a reasonable amount of use and are covered by a 90 day limited warranty against manufacturer's defects.

Who is Covered

This warranty covers only the initial purchaser of the product from the date of delivery.

What is Covered

This warranty covers any defects in workmanship or materials subject to the limitations stated below. This warranty does not cover failures due directly or indirectly to misuse, abuse, negligence or accidents, normal wear-and-tear, improper repair, alterations or lack of maintenance. JET woodworking machinery is designed to be used with Wood. Use of these machines in the processing of metal, plastics, or other materials may void the warranty. The exceptions are acrylics and other natural items that are made specifically for wood turning.

Warranty Limitations

Woodworking products with a Five Year Warranty that are used for commercial or industrial purposes default to a Two Year Warranty. Please contact Technical Service at 1-800-274-6846 for further clarification.

How to Get Technical Support

Please contact Technical Service by calling 1-800-274-6846. **Please note that you will be asked to provide proof of initial purchase when calling.** If a product requires further inspection, the Technical Service representative will explain and assist with any additional action needed. JET has Authorized Service Centers located throughout the United States. For the name of an Authorized Service Center in your area call 1-800-274-6846 or use the Service Center Locator on the JET website.

More Information

JET is constantly adding new products. For complete, up-to-date product information, check with your local distributor or visit the JET website.

How State Law Applies

This warranty gives you specific legal rights, subject to applicable state law.

Limitations on This Warranty

JET LIMITS ALL IMPLIED WARRANTIES TO THE PERIOD OF THE LIMITED WARRANTY FOR EACH PRODUCT. EXCEPT AS STATED HEREIN, ANY IMPLIED WARRANTIES OF MERCHANTABILITY AND FITNESS FOR A PARTICULAR PURPOSE ARE EXCLUDED. SOME STATES DO NOT ALLOW LIMITATIONS ON HOW LONG AN IMPLIED WARRANTY LASTS, SO THE ABOVE LIMITATION MAY NOT APPLY TO YOU.

JET SHALL IN NO EVENT BE LIABLE FOR DEATH, INJURIES TO PERSONS OR PROPERTY, OR FOR INCIDENTAL, CONTINGENT, SPECIAL, OR CONSEQUENTIAL DAMAGES ARISING FROM THE USE OF OUR PRODUCTS. SOME STATES DO NOT ALLOW THE EXCLUSION OR LIMITATION OF INCIDENTAL OR CONSEQUENTIAL DAMAGES, SO THE ABOVE LIMITATION OR EXCLUSION MAY NOT APPLY TO YOU.

JET sells through distributors only. The specifications listed in JET printed materials and on official JET website are given as general information and are not binding. JET reserves the right to effect at any time, without prior notice, those alterations to parts, fittings, and accessory equipment which they may deem necessary for any reason whatsoever. JET® branded products are not sold in Canada by JPW Industries, Inc.

Product Listing with Warranty Period

90 Days – Parts; Consumable items
1 Year – Motors; Machine Accessories
2 Year – Metalworking Machinery; Electric Hoists, Electric Hoist Accessories; Woodworking Machinery used for industrial or commercial purposes
5 Year – Woodworking Machinery
Limited Lifetime – JET Parallel clamps; VOLT Series Electric Hoists; Manual Hoists; Manual Hoist Accessories; Shop Tools; Warehouse & Dock products; Hand Tools; Air Tools

NOTE: JET is a division of JPW Industries, Inc. References in this document to JET also apply to JPW Industries, Inc., or any of its successors in interest to the JET brand.

2.0 Table of contents

Section	Page
1.0 Warranty and Service.....	2
2.0 Table of contents.....	3
3.0 Safety warnings.....	4
4.0 About this manual	5
5.0 Specifications	6
6.0 JTM-1050EVS installation layout	7
7.0 JTM-1050EVS features and terminology	8
8.0 Setup and assembly.....	9
8.1 Unpacking	9
8.2 Contents of shipping container	9
8.3 Site preparation	10
8.4 Lifting the mill	10
8.5 Completing assembly	10
8.6 Lubrication.....	11
9.0 Electrical Connections.....	11
9.1 Wire Sizes	11
10.0 Operating controls.....	12
11.0 Operating precautions.....	13
12.0 Adjustments	13
12.1 Drawbar operation - changing tooling	13
12.2 Clamping workpiece to table	13
12.3 Changing speed range	14
12.4 Manual feed.....	14
12.5 Automatic feed	14
12.6 Mill head – left/right movement	15
12.7 Mill head – angle setting.....	16
12.8 Ram movement	16
12.9 Table movement.....	16
12.10 Feed trip adjustment.....	17
12.11 Variable frequency drive.....	17
13.0 Maintenance.....	17
13.1 General maintenance	17
13.2 Lubrication.....	17
13.3 Gib adjustment	18
13.4 Leadscrew backlash adjustment	18
14.0 Replacement parts	20
14.1.1 JTM-1050EVS Inverter Speed Head Assembly – Exploded View	20
14.1.2 JTM-1050EVS Inverter Speed Head Assembly – Parts List	21
14.2.1 JTM-1050EVS Head Assembly – Exploded View	23
14.2.2 JTM-1050EVS Head Assembly – Parts List.....	24
14.3.1 JTM-1050EVS Base Assembly – Exploded View	27
14.3.2 JTM-1050EVS Base Assembly – Parts List	28
14.4.1 JTM-1050EVS Table Leadscrew Assembly – Exploded View	30
14.4.2 JTM-1050EVS Table Leadscrew Assembly – Parts List	31
14.5.1 JTM-1050EVS One-Shot Lubrication System – Exploded View	32
14.5.2 JTM-1050EVS One-Shot Lubrication System – Parts List	32
14.6.1 JTM-1050EVS Electrical Panel – Parts List	33
14.6.2 JTM-1050EVS Electrical Panel Layout I	33
14.6.3 JTM-1050EVS Electrical Panel Layout II	34
15.0 Electrical connections for JTM-1050EVS.....	35
15.1 JTM-1050EVS wiring diagram.....	35
15.2 JTM-1050EVS wiring diagram.....	36



3.0 Safety warnings

1. Read and understand the entire owner's manual before attempting assembly or operation.
2. Read and understand the warnings posted on the machine and in this manual. Failure to comply with all of these warnings may cause serious injury.
3. Replace the warning labels if they become obscured or removed.
4. This turret mill is designed and intended for use by properly trained and experienced personnel only. If you are not familiar with the proper and safe operation of a turret mill, do not use until proper training and knowledge have been obtained.
5. Do not use this turret mill for other than its intended use. If used for other purposes, JET, disclaims any real or implied warranty and holds itself harmless from any injury that may result from that use.
6. Always wear approved safety glasses/face shields while using this mill. Everyday eyeglasses only have impact resistant lenses; they are not safety glasses.
7. Before operating this machine, remove tie, rings, watches and other jewelry, and roll sleeves up past the elbows. Remove all loose clothing and confine long hair.
8. Non-slip safety footwear and anti-skid floor strips are recommended. Do not wear gloves.
9. Never place hands near or around a revolving tool or part.
10. Wear ear protectors (plugs or muffs) during extended periods of operation.
11. Some dust created by power sanding, sawing, grinding, drilling and other construction activities contain chemicals known to cause cancer, birth defects or other reproductive harm. Some examples of these chemicals are:
 - Lead from lead based paint.
 - Crystalline silica from bricks, cement and other masonry products.
 - Arsenic and chromium from chemically treated lumber.
 1. Your risk of exposure varies, depending on how often you do this type of work. To reduce your exposure to these chemicals, work in a well-ventilated area and work with approved safety equipment, such as face or dust masks that are specifically designed to filter out microscopic particles.
12. Do not operate this machine while tired or under the influence of drugs, alcohol or any medication.
13. Make certain the switch is in the OFF position before connecting the machine to the power supply.
14. Make certain the machine is properly grounded.
15. Make all machine adjustments or maintenance with the machine unplugged from the power source.
16. Workpiece must be attached or clamped to the table. Never hold a workpiece with your hand.
17. Use correct spindle speed and table feed for the particular job.
18. Do not start machine with cutter in contact with workpiece.
19. Remove adjusting keys and wrenches. Form a habit of checking to see that keys and adjusting wrenches are removed from the machine before turning it on.
20. Keep safety guards in place at all times when the machine is in use. If removed for maintenance purposes, use extreme caution and replace the guards immediately after completion of maintenance.
21. Check damaged parts. Before further use of the machine, a guard or other part that is damaged should be carefully checked to determine that it will operate properly and perform its intended function. Check for alignment of moving parts, binding of moving parts, breakage of parts, mounting and any other conditions that may affect its operation. A guard or other part that is damaged should be properly repaired or replaced.
22. Provide for adequate space surrounding work area and non-glare, overhead lighting.
23. Keep the floor around the machine clean and free of scrap material, oil and grease.
24. Keep visitors a safe distance from the work area. Keep children away.
25. Make your workshop child proof with padlocks, master switches or by removing starter keys.
26. Give your work undivided attention. Looking around, carrying on a conversation and "horse-play" are careless acts that can result in serious injury.
27. Maintain a balanced stance at all times so that you do not fall into the cutter or other moving parts. Do not overreach or use excessive force to perform any machine operation.

28. Use the right tool at the correct speed and feed rate. Rotate spindle clockwise for right-hand tools, counterclockwise for left-hand tools. Do not force a tool or attachment to do a job for which it was not designed. The right tool will do the job better and more safely.
29. Use recommended accessories; improper accessories may be hazardous.
30. Frequently clean this machine. Maintain tools with care. Keep cutters sharp and clean for the best and safest performance. Follow instructions for lubricating and changing accessories.
31. Turn off the machine before cleaning. Use a brush or compressed air to remove chips or debris — do not use your hands.
32. Do not stand on the machine. Serious injury could occur if the machine tips over.
33. Never leave the machine running unattended. Turn the power off and do not leave the machine until it comes to a complete stop.
34. Remove loose items and unnecessary work pieces from the area before starting the machine.
35. Don't use in dangerous environment. Don't use this machine in damp or wet locations, or expose it to rain. Keep work area well lighted.
36. Some coolants used for machining contain chemicals that may be hazardous to your health if not used properly. Read and understand all user information listed on the coolant container and protect yourself accordingly.

The JTM-1050EVS mill is pre-wired from the factory. Stock number 690060 is pre-wired 230 volt. Stock number 690062 is pre-wired 460V. This machine is not dual voltage. This machine cannot be used with a phase converter.

2.

Familiarize yourself with the following safety notices used in this manual:

CAUTION This means that if precautions are not heeded, it may result in minor injury and/or possible machine damage.

WARNING This means that if precautions are not heeded, it may result in serious, or possibly even fatal, injury.

4.0 About this manual

This manual is provided by JET covering the safe operation and maintenance procedures for a JET Model JTM-1050EVS Turret Mill. This manual contains instructions on installation, safety precautions, general operating procedures, maintenance instructions and parts breakdown. Your machine has been designed and constructed to provide consistent, long-term operation if used in accordance with the instructions as set forth in this document.

This manual is intended to familiarize you with the technical aspects of this milling machine. It is not, nor was it intended to be, a training manual. Do not operate this machine until appropriate training and knowledge have been acquired.

If there are questions or comments, please contact your local supplier or JET. JET can also be reached at our web site: www.jettools.com.

Retain this manual for future reference. If the machine transfers ownership, the manual should accompany it.

WARNING Read and understand the entire contents of this manual before attempting assembly or operation! Failure to comply may cause serious injury!

5.0 Specifications

Model Number.....	JTM-1050EVS/230	JTM-1050EVS/460
Stock Number	690060	690062

Motor and Electricals:

Motor type	TEFC	TEFC
Horsepower	3 HP (2.2 kW)	3 HP (2.2 kW)
Phase	3	3
Voltage	230V only	460V only
Cycle	60Hz	60Hz
Listed FLA (full load amps)	8.2	4.1
Motor Speed (RPM)	1720	1720
Power transfer	belt	belt
Sound Emission (tested at 3 ft. from machine):		
Without load	75 dB	75 dB
With load	80-85 dB	80-85 dB

Head and Spindle:

Spindle Taper	R-8	R-8
Diameter of Quill (in.)	3-3/8	3-3/8
Number of Spindle Speeds	Variable	Variable
Range of Spindle Speeds (RPM)	10 to 3600	10 to 3600
Downfeeds per Revolution of Spindle (in.)	0.0015, 0.003, 0.006	0.0015, 0.003, 0.006
Spindle Travel (in.)	5	5
Head Movement – Left and Right (deg.)	90	90
Head Movement – Fore and Aft (deg.)	45	45
Maximum Distance Spindle Nose to Table (in.)	19	19
Maximum Distance Spindle Center to Column (in.)	26	26
Minimum Distance Spindle Center to Column (in.)	5-1/2	5-1/2
Collet Capacity (in.)	1/8 – 7/8	1/8 – 7/8
Ram Travel, maximum (in.)	20-1/2	20-1/2

Table:

Table Size (in.)	10 x 50	10 x 50
Longitudinal Table Travel, maximum (in.)	30	30
Table Cross Travel, maximum (in.)	15-1/4	15-1/4
Number of T-Slots	3	3
T-Slot Size, width (in.)	5/8	5/8
T-Slot Centers (in.)	2-1/2	2-1/2
Table Load, maximum (lbs.)	720	720
Knee Travel, maximum (in.)	14-1/4	14-1/4

Dimensions:

Overall Dimensions, assembled (in.)	96 W x 71 D x 88 H	96 W x 71 D x 88 H
---	--------------------	--------------------

Weights:

Net Weight, approx. (lbs.)	3000	3000
Shipping Weight, approx.. (lbs.)	3050	3050

The specifications in this manual were current at time of publication, but because of our policy of continuous improvement, JET reserves the right to change specifications at any time and without prior notice, without incurring obligations.

6.0 JTM-1050EVS installation layout

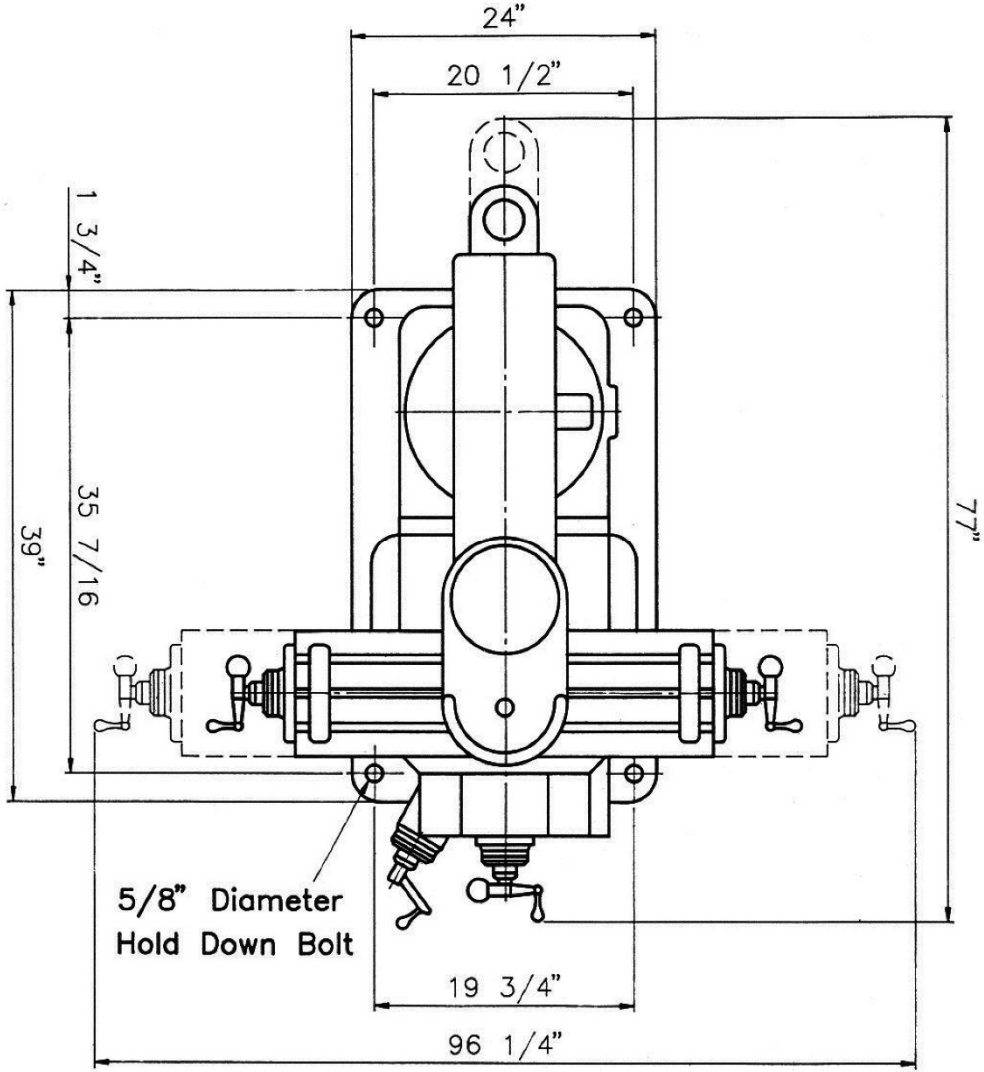

Figure 1

7.0 JTM-1050EVS features and terminology

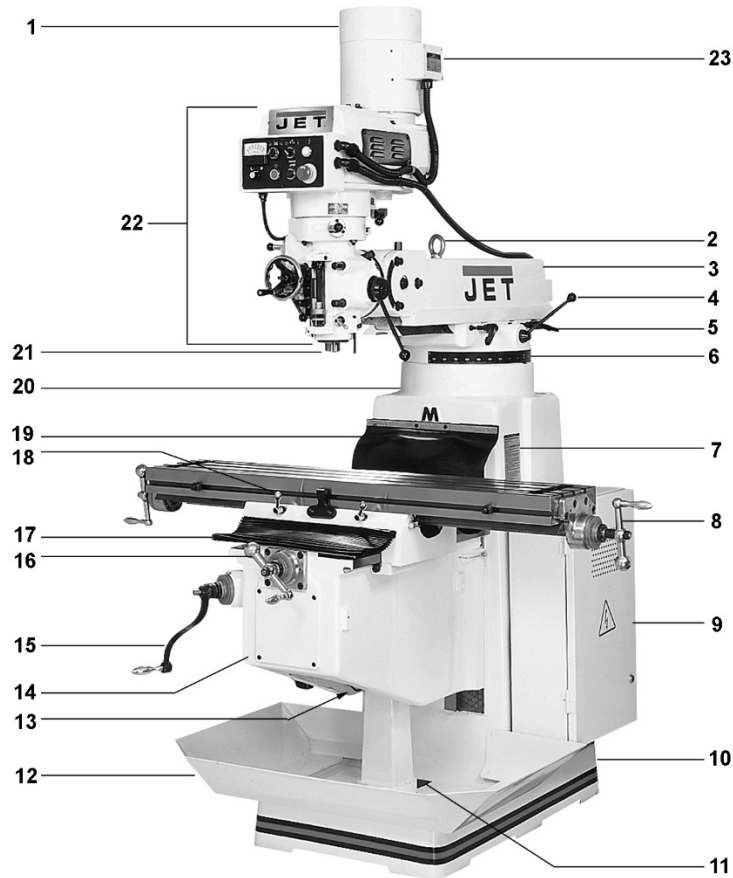

Figure 2: Features and Terminology

- | | |
|--|--|
| <ul style="list-style-type: none"> 1. 3HP Motor 2. Lifting ring 3. Ram 4. Ram movement lever 5. Ram locking handle (x2) 6. Turret scale 7. I.D./Warning Label 8. Table longitudinal crank handle (x2) 9. Electrical box 10. Base 11. Strainer (for use with optional flood coolant systems) 12. Chip tray 13. Elevating leadscrew 14. Knee 15. Knee crank handle 16. Crossfeed handle 17. Pleated way cover 18. Table locking handle (x2) 19. Flat way cover 20. Column 21. Spindle | <ul style="list-style-type: none"> 22. Head assembly (see section 10.0 for explanation of controls) 23. Motor junction box 24. Saddle locking handle 25. Lubrication chart 26. One-shot lube system 27. Knee locking handle (x2) |
|--|--|

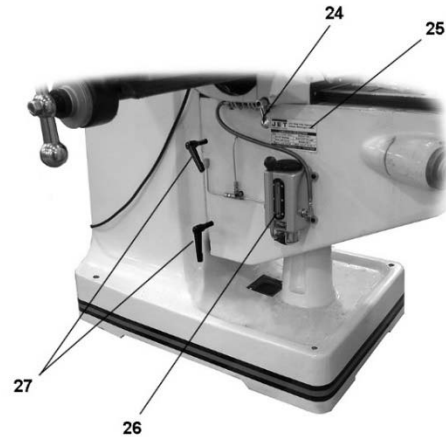

Figure 2a

8.0 Setup and assembly

8.1 Unpacking

Open shipping container and check for shipping damage. Report any damage immediately to your distributor and shipping agent. Do not discard any shipping material until the Turret Mill is assembled and running properly.

Compare the contents of your container with the following parts list to make sure all parts are intact. Missing parts, if any, should be reported to your distributor. *Note: Check the mill first – some parts may have been pre-installed.*

Read the instruction manual thoroughly for assembly, maintenance and safety instructions.

8.2 Contents of shipping container

Refer to Figure 3:

- 1 Turret Mill (not shown)
- 1 Flat Way Cover
- 1 Pleated Way Cover
- 1 Draw Bar
- 3 Table Adjustment Handles
- 1 Tool Box, containing:
 - 1 Hex Key Set (1.5-10mm) *
 - 1 17/19mm Box Wrench *
 - 1 Cross Point Screw Driver #2 *
 - 1 Flat Blade Screw Driver #2 *
 - 1 Plastic Oil Bottle *
 - 1 Elevating Crank Handle
 - 1 Handwheel
 - 1 Coarse Feed Handle
 - 1 Can White Touch Up Paint
 - 1 Lifting Ring
 - 1 Operator's Manual (not shown)
 - 1 Warranty Card (not shown)

** parts with an asterisk are also included in the tool box service kit, p/n JTM4VS-TB.*



Figure 3: Shipping contents

⚠WARNING Read and understand the entire contents of this manual before attempting set-up or operation! Failure to comply may cause serious injury.

NOTE

If your mill is supplied with an optional Table Powerfeed and/or DRO, be sure to consult the separate instruction materials that accompany them.

8.3 Site preparation

The mill must be placed on an even surface and bolted to the floor. Anchor bolts of sufficient size and length must be fastened to the floor according to the mill's footprint. See the site installation diagram in Figure 1.

When spotting the machine be certain to leave room not only for the machine itself, but also for operator clearance and clearance for workers servicing the machine, and any unusual sizes of workpieces that might extend off the machine's table.

8.4 Lifting the mill

Finish removing the sides of the crate. Leave mill bolted to pallet until ready to move to its final location.

The preferred method for lifting is with a hook through the lifting ring screwed into the tapped hole atop the ram. Steady the mill to prevent it from spinning.

Check the lifting ring on the ram to be certain it is tight.

Check the tightness of the lock handles on the ram (A, Figure 4) to be certain the ram is tightly locked.

An alternative method for lifting the mill is with a sling. Follow diagram in Figure 4 for proper position of sling under ram. Note position of ram and that table has been moved against column. Tighten ram locking bolts (A, Figure 4) before lifting.

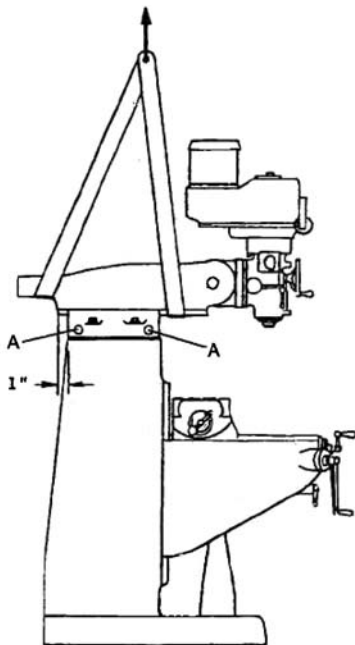

Figure 4: sling location

1. Remove the nuts and/or bolts, which secure the machine to the pallet.

2. Center an overhead crane or other suitable overhead lifting device and sling arrangement over the lifting ring.

3. **Note:** This machine weighs 3000 pounds. Be certain the lifting arrangement is new or in excellent condition and has a safety factor that will account for age, difficulties in lifting, etc. When lifting using the ring, the machine may tend to tip forward. If you wish, you can minimize this tipping by rigging a support sling over the front of the machine. Be careful when doing this, to prevent the sling from damaging any components on the front of the machine. Be sure to steady the mill to prevent it from spinning.

3. Lift the machine off the pallet no higher than necessary to clear the hold-down hardware, then pull the pallet out of the way. Do NOT get hands or feet underneath the machine when removing the pallet.

4. Lower the mill over the anchor bolts. Level the machine using shims under the corners needing them. The machinist's level used for leveling should be placed on the table. The table is the reference surface for both side-to-side and fore-and-aft leveling. Be certain you get it level in BOTH directions.

CAUTION Mill must be supported equally under all four corners. Failure to comply may cause the column to twist and put a bind in the table ways.

5. When the machine is level, secure the base to the anchoring system.

8.5 Completing assembly

CAUTION Before attempting to raise mill head, familiarize yourself with instructions in section 12.6, for procedures to safely raise and set up the mill head.

1. Loosen the four hexagonal nuts (see A, Figure 9) about one-quarter (1/4) turn each counter-clockwise, just enough to allow rotation of the head.
2. Apply upward pressure on motor by hand to relieve pressure on worm mechanism, and use supplied wrench to turn worm nut (B, Figure 8) and raise head to upright position.
3. Tighten nuts (A, Figure 9); not torqued at this time, just snug. Before operating mill, follow procedures in section 12.5 to verify angle settings and properly tighten the four nuts.
4. Using mineral spirits or other cleaning solvent, clean all of the rust proofing from where it may have been applied. This is important; moving the table or any other components before

removing the rust proofing will only put rust proofing where you don't want it. (Do not use gasoline, paint thinner, or lacquer thinner. These will damage painted surfaces.)

5. Lubricate exposed ways, then move each unit (table and ram) to the opposite limit stop, and clean and lubricate the newly exposed ways. Loosen bolts to unlock ram and move it forward and backward to the full length in order to clean and lubricate.
6. Cover all machined surfaces with a film of light machine tool oil to inhibit rust.
4. Some of the following steps may have already been performed on the machine. If so, ignore the instructions related to those particular steps. Otherwise, perform them in the order listed. Refer to Figures 2 and 5 to help locate items.
7. Install the table longitudinal and cross-feed crank handles on their respective shafts using the nuts on the shafts to secure them.
8. Remove any rust proofing from the drawbar and its washer, and put the drawbar with washer installed into the spindle center.
9. Slide the fine feed handwheel over the handwheel hub and push it back until its roll pin engages the hole in the hub and the wheel is flush with the hub surface.
10. Put the coarse feed handle on the feed shaft and tap it lightly until its roll pin engages a hole in the hub and it is flush against the hub surface.
11. Unwrap and clean the elevating (knee) crank and install it on its shaft.
12. Install the rubber way covers at front and behind the table.
13. Install the chip tray on the base.

8.6 Lubrication

CAUTION Do not operate the mill before lubricating the machine fully. Failure to comply may cause damage to the machine.

Before operating mill, refer to sect. 13.2 for lubricating instructions.

9.0 Electrical Connections

WARNING All electrical connections must be made by a qualified electrician. Failure to comply may cause serious or fatal injury.

The JTM-1050EVS mill is pre-wired from the factory. Stock number 690060 is pre-wired 230 volt. Stock number 690062 is pre-wired 460V. This machine is not dual voltage.

This machine cannot be used with a phase converter.

Confirm power at the site matches power requirements of the mill before connecting to the power source. The power source should be dedicated to the JTM-1050EVS mill. The main power switch is located on the right side of the machine.

Remove the cover, and run the main power cable through the box and attach the ground, followed by power leads. Replace the cover.

Check for proper spindle rotation *in the high speed range*. The spindle should rotate clockwise when viewed from the top of the machine. If the spindle rotates counterclockwise, disconnect from the power source, and switch two of the power leads.

The mill must be properly grounded.

9.1 Wire Sizes

CAUTION For circuits which are far away from the electrical service box, the wire size must be increased in order to deliver ample voltage to the motor. To minimize power losses and to prevent motor overheating and burnout, the use of wire sizes for branch circuits or electrical extension cords according to the following table is recommended:

Conductor Length	AWG Number
	230/460 Volt Lines
0 – 50 Ft.	No. 14
50 – 100 Ft.	No. 14
Over 100 Ft.	No. 12

Table 1

10.0 Operating controls

Refer to Figure 5.

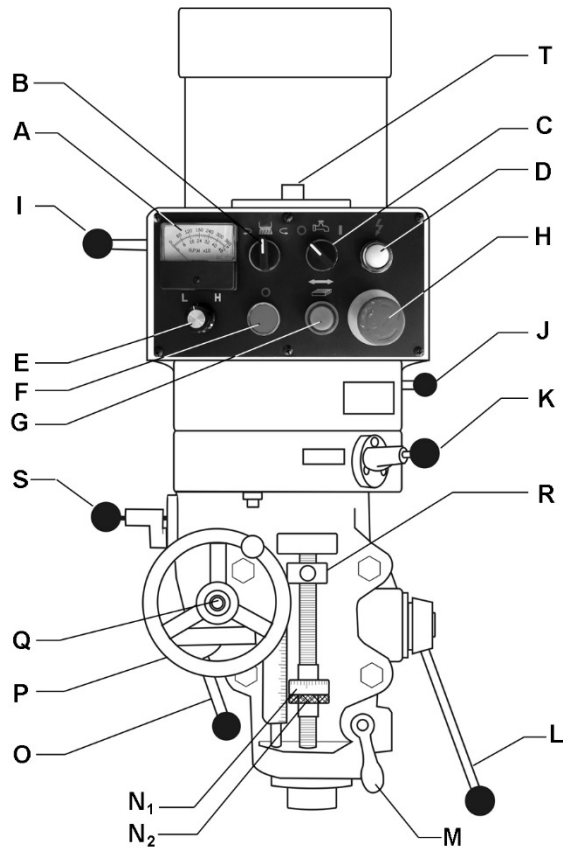

Figure 5: Controls

- A. **RPM gauge (A)**.
- B. **Reversing switch (B)** – Changes rotation direction of spindle.
- C. **Coolant switch (C)**- installed for optional coolant pump. The wiring must be hooked to U2, V2 and W2 in the terminal strip.
- D. **Power lamp (D)** – indicates electrical power is flowing to the machine.
- E. **Low/High switch (E)** – sets speed range.
- F. **Spindle switch (F)** – engages spindle rotation.
- G. **Power feed (G)** – installed for optional automatic feed. The wiring must be hooked to 110V, 0V in the terminal strip.
- H. **Emergency stop switch (H)** – shuts down all controls on machine. Rotate switch clockwise to disengage and restart machine.
- I. **Spindle brake (I)** - located on left side of head. Move in either direction to stop spindle once power has been turned off.
- J. **High-Neutral-Low Lever (J)** - located on right side of head. Upper position is high speed. Middle position is neutral. Lower position is low speed (back gear engagement).
- CAUTION** Do not shift High-Low Gear (D) while motor is running. Turn off machine and rotate spindle by hand to facilitate changing lever positions.
- K. **Auto feed engagement lever (K)** - located on right side of head. When lever is in the right-hand hole, the auto feed worm gear is disengaged. To engage auto feed, pull knob out and move lever around to opposite hole. Engage pin in hole.
- CAUTION** Auto feed may be engaged when spindle is rotating, however, it must be engaged gently to avoid damage to worm gear.
- Do not use auto feed at speeds above 3000 R.P.M.
 - It is recommended that auto feed worm gear be disengaged whenever auto feed is not required. This avoids unnecessary wear on the worm gear.
 - Maximum auto feed loading is a 3/8" (9.5mm) diameter bit for drilling in steel. Use manual feed for bits larger than 3/8".
- L. **Coarse feed handle (L)** - located on right side of head. Used for non-precision drilling operations and for moving quill to a specific depth. Rotate clockwise to lower spindle. A return spring retracts spindle automatically when handle is released.
- M. **Quill lock (M)** - located on right side of head. Rotate handle clockwise to lock quill in desired position. Rotate handle counter-clockwise to release.
- N. **Micrometer adjusting nut (N₁,N₂)** - located on front of head. Used for setting spindle depth, according to the adjoining scale. Use jam nut (H₂) to secure setting of adjusting nut (H₁). **Note:** One complete rotation of the micrometer adjusting nut equals 0.05".

- O. **Feed trip control lever (O)** - located on left side of head. Engages overload clutch on pinion shaft when lever is positioned to the left. Stays engaged until quill stop comes into contact with micrometer adjusting nut (forcing feed control lever to drop out automatically), or until lever is released manually by positioning lever to the right.
- P. **Manual feed handwheel (P)** – located on left front of head. Feed direction control knob (Q) must be in neutral position. The feed control lever (O) must be engaged. **Note:** Manual feed handwheel may be taken off when not in use.
- Q. **Feed direction control (Q)** – located in center of manual feed handwheel. Position of knob depends upon direction of spindle rotation. If boring with right hand cutting tools, pull feed knob towards operator until clutch becomes engaged. Neutral position is between forward and reverse position. (Refer to Figure 8 and accompanying text for further detail.) If control does not engage easily, move handwheel (P) back and forth to aid engagement.
- R. **Quill stop (R)** – located on front of head. Used to disengage automatic feed in either direction as well as the setting point for working to a given depth.
- S. **Quill feed speed selector (S)** – located on left side of head. Pull knob out and locate handle over choice of three feed speeds (0.0015", 0.003", and 0.006") per spindle revolution. The selector shifts into engagement more easily when the spindle is rotating.
- T. **Drawbar (T)** – located on top of head. Used to secure tool holder in the taper. Use the spindle brake (C) while tightening drawbar.

CAUTION It is recommended that feed direction knob be left in neutral position when not in use.

11.0 Operating precautions

- Do not attempt to change spindle RPM while motor is stopped. Only change spindle speeds while motor is running.
- Verify that spindle brake is released before starting motor.
- Rotate spindle by hand to facilitate meshing of clutch and gears.
- Do **not** use quill automatic feed at speeds above 2700 RPM.

- It is recommended that the auto feed worm gear be disengaged whenever auto feed is not required. This will avoid unnecessary wear on the worm gear.
- Maximum auto feed loading is a 3/8" (9.5mm) diameter bit for drilling in mild steel. Use manual feed for bits larger than 3/8".
- Overload clutch is factory set to hold up to 200 lbs. down feed pressure on the quill (accommodates drills up to 3/8"). Do **not** attempt to adjust clutch pressure.

12.0 Adjustments

12.1 Drawbar operation - changing tooling

1. Apply the spindle brake and loosen the draw bar two or three turns (counterclockwise) with the provided wrench placed over the draw bar hex (T, Figure 5).
2. Tap the top of the draw bar with a soft-faced hammer to loosen the collet from the taper.
3. Remove the tool from the collet.
4. Insert the tool you are going to use into the collet.
5. Tighten the draw bar firmly using the provided wrench with spindle brake applied. The tool is now ready for use.

12.2 Clamping workpiece to table

The worktable has 5/8-inch T-slots for clamping work piece to table.

1. Set switch to OFF position.
1. Place work piece on table.
2. Clamp work piece using T-slot clamps, studs, and step blocks as required. See Figure 6.

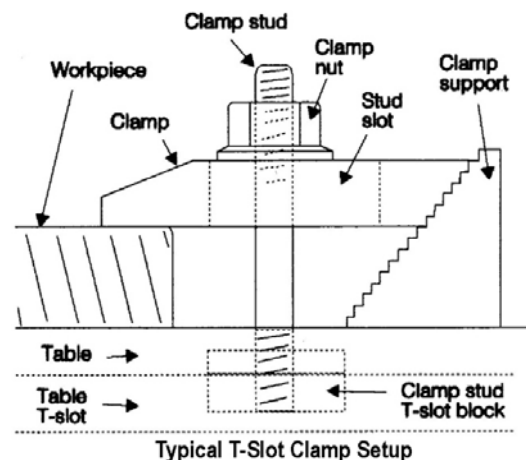

Figure 6: Work piece clamping

12.3 Changing speed range

To change from high to low speed range, push in lever (J, Figure 5) and rotate it almost 180 degrees. Lever will stay in position once pressure is released.

CAUTION Do not change gears while spindle is running. Rotate spindle by hand to ensure clutch is engaged prior to turning on. Do not turn on machine unless spindle can be moved freely.

12.4 Manual feed

12.4.1 Manual fine feed (handwheel)

Refer to Figure 7.

1. Disengage automatic feed by pulling out knob (E, Figure 7) and moving lever to the right hole.
2. Position feed reversing knob (K) to the center, or neutral, position.
3. Engage feed trip lever (I) by pulling away from the head assembly.
4. The quill can now be moved up or down by turning handwheel (J, Figure 5).

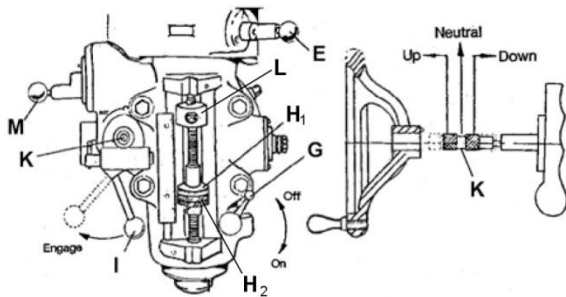

Figure 7: Manual feed controls

12.4.2 Manual coarse feed (handle)

Refer to Figure 7.

1. Disengage automatic feed by pulling out knob (E, Figure 7) and moving lever to the right hole.
2. Position feed reversing knob (K) to the center, or neutral, position.
3. Disengage feed trip lever (I) by pushing towards head assembly.
4. Use coarse feed handle (F, Figure 5) to move the spindle.

12.4.3 Micrometer adjusting nuts for manual feed

Refer to Figures 5 and 7.

1. Lower quill to required depth.
2. Tighten quill lock (G, Figure 7).

3. Screw the micrometer nut (H_1) against quill stop (L), and tighten micrometer jam nut (H_2).
4. Loosen quill lock (G).
5. Use coarse or fine manual downfeed.

Note: Always make a test cut to verify that depth of cut is correct.

12.5 Automatic feed

Refer to Figure 7.

1. Ensure quill lock (G, Figure 7) is loosened by rotating counterclockwise.
2. Set micrometer nut (H) to desired depth.
3. Engage auto feed lever by pulling out lock knob (E) and moving lever to the left hole.
4. Select feed direction by setting feed direction knob (K) position per Table 2.

5. Spindle dir.	6. Feed dir.	7. Knob position
8. CW	9. Down	10. In
	11. Up	12. Out
13. CCW	14. Down	15. Out
	16. Up	17. In

Table 2

5. Select feed rate from feed selector knob (M) 0.0015", 0.003", and 0.006" per spindle revolution. It is easier to change feed rate while the spindle is turning.
6. Engage feed trip lever (I, Figure 7) by pulling away from head assembly.

CAUTION Automatic (power) feed may be engaged when spindle is rotating, however, it must be engaged *gently* to avoid damage to the worm gear.

- Do not use power feed at speeds above 2700 R.P.M.
- It is recommended that the power feed worm gear be disengaged whenever the power feed is not required.
- Maximum loading is a 3/8" (9.5mm) diameter bit for drilling in steel. Use manual feed for bits larger than 3/8".

Note: Due to variables in tool diameter, coatings, coolant, and materials, no specific spindle speed or feed rate recommendations are provided. Use general shop manuals that have data applicable to the milling and drilling operations being performed. Or, contact the supplier of the tooling, coolant and material for specific recommendations.

12.5.1 Micrometer adjusting nuts for auto feed

Refer to Figures 5 and 7.

1. Lower quill to required depth.
2. Tighten quill lock (G, Figure 7).
3. Screw micrometer nut (H_1) against quill stop (L), and tighten micrometer jam nut (H_2).
4. Loosen quill lock (G), and engage auto feed lever (E).
5. Choose downfeed rate (M).
6. Engage feed reversing knob (K).
7. Engage feed trip lever (I).

Note: Always make a test cut to verify that depth of cut is correct.

12.6 Mill head – left/right movement

WARNING Make sure machine base is secured to floor before repositioning mill head. The center of gravity can shift enough to cause the machine to tip over, resulting in serious injury to operator and damage to machine.

1. Loosen four large hexagonal nuts that secure the mill head to the ram adapter (refer to Figure 8). One-quarter ($1/4$) turn should be sufficient to allow the head to move.

NOTE: For angles greater than 10 degrees, use your free hand to support the mill head, taking some weight off the brass worm gears. Doing so will greatly lengthen the life of the worm gears.

2. Turn worm nut (B, Figure 8) to tilt head left or right as required. Use the scale on the ram adapter to set desired angle.

NOTE: The scales on the ram adapter and for head rotation are guides only. Close tolerance work will require the use of a dial indicator to make sure the head is 90° to the table in the X and Y axis. Please note the table is fitted to be slightly higher in front, usually about 0.0005 ".

CAUTION Be sure to apply torque in two steps using a crossing pattern. Failure to do so could distort the face of the ram adapter.

3. Tighten the four hexagonal nuts. Tighten in two steps using a calibrated torque wrench. Use a crossing pattern to tighten the nuts. Tighten initially to 25 foot-pounds.
4. Before applying final torque, check to make sure the mill head is perpendicular to the worktable.

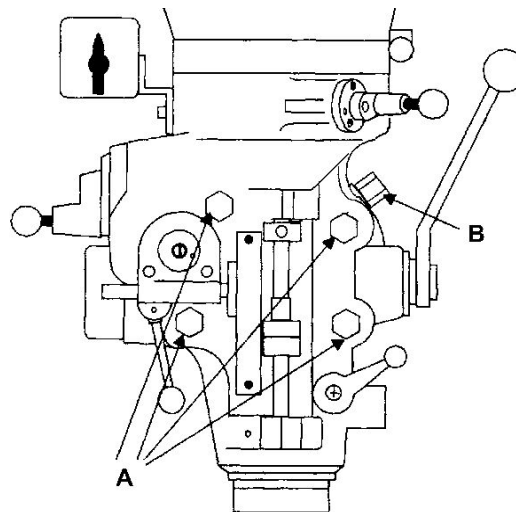

Figure 8: Mill head movement

5. Set up a dial indicator in a collet and secure using the draw bar (refer to Figure 9).

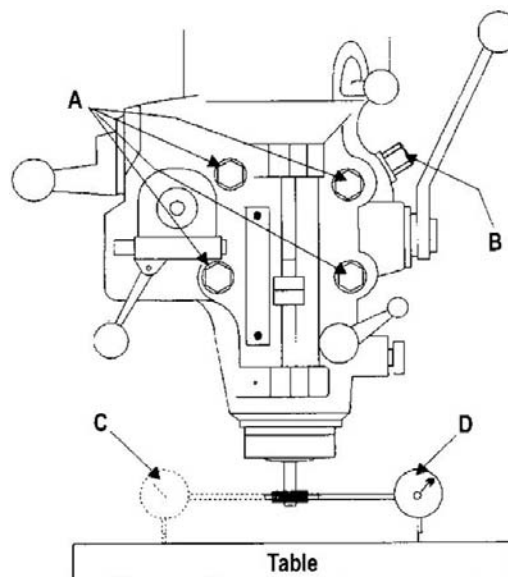

Figure 9: Test perpendicularity

6. Put spindle drive in neutral.
7. Set dial indicator plunger on worktable. Zero the indicator.
8. Rotate spindle 180 degrees (when rotating, raise dial indicator plunger by hand to prevent it from dropping into table T-slots).
9. Read dial indicator – it should read zero. If not, loosen the four hex nuts and reposition the mill head.
10. Recheck perpendicularity using dial indicator. Repeat procedure above until dial indicator reads zero in both positions.

CAUTION Be sure to apply torque in two steps using a crossing pattern. Failure to do so could distort the face of the ram adapter.

11. Tighten the four hex nuts. Tighten in two steps using a calibrated torque wrench. Use a crossing pattern to tighten the nuts. Tighten to a final torque of 50 foot-pounds.

12.7 Mill head – angle setting

1. Setting the angle:
 - a. Loosen the three ram adapter clamp bolts (E, Figure 10). There is no need to loosen the bolts more than one-half (1/2) turn to allow tilting.

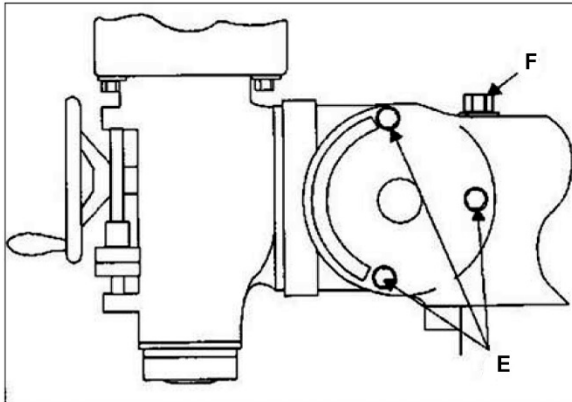

Figure 10: Mill head movement

- b. Support the mill head with your free hand. Press upward on the spindle when changing the angle.
 - c. Turn ram adapter worm nut (F, Figure 10) to tilt head forward and backward. Use scale on ram adapter to locate desired angle.
2. Returning to upright position:
 - a. When returning mill head to full upright position, support head by upward pressure on the spindle as you turn worm nut.
 - b. Check to make sure mill head is perpendicular to worktable.
 - c. Set up a dial indicator in a collet and secure using the draw bar (refer to Figure 9).
 - d. Put spindle drive in neutral.
 - e. Set dial indicator plunger on worktable. Zero the indicator.
 - f. Rotate spindle 180 degrees. (When rotating, raise dial indicator plunger by hand to prevent it from dropping into the table T-slots).
 - g. Read dial indicator. The indicator should read zero. If not, loosen adaptor bolts (E, Figure 10) and reposition mill head.
 - h. Recheck perpendicularity using dial indicator. Repeat procedure above until dial indicator reads zero in both positions.
 - i. When indicator reads zero, tighten ram adapter clamp bolts (E, Figure 10).

12.8 Ram movement

12.8.1 Ram position fore and aft

Refer to Figure 11.

1. Loosen handles (G, Figure 11) that lock the ram to its ways.
2. Turn lever (H) to slide ram.
3. When desired position is reached, lock handles (G) securely.

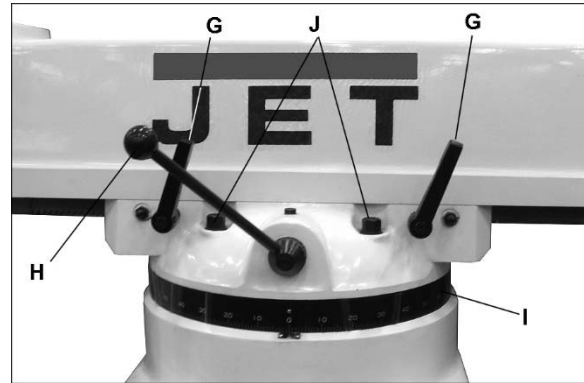

Figure 11: Ram positioning

12.8.2 Rotating ram on turret

Refer to Figure 11.

⚠WARNING Make sure machine base is secured to floor before repositioning ram. The center of gravity can shift enough to cause machine to tip over, resulting in serious injury to operator and damage to machine.

1. Loosen four turret lock bolts (J, Figure 11) that clamp the ram to the top of the base. One-half (1/2) turn should be sufficient to allow the turret to move.

Note: Use gentle hand pressure to avoid rapid movement.
2. Swing the ram until spindle is in desired position. Use scale (I) on turret for degree measurement.
3. Tighten the four turret lock bolts (J).

12.9 Table movement

Refer to Figure 12.

- A. **Longitudinal Movement** (A, Figure 12) - handles located on opposite ends of table; control the X-axis.
- B. **Stops** (B) - located on front of table; limit how far table travels in either direction.
- C. **Table Locks** (C) - located on front of saddle; used for locking table in position.
- D. **Cross Feed Movement** (D) - located on front of knee; controls the Y-axis.

- E. **Knee Handle (E)** - located on corner of knee; controls the Z-axis.

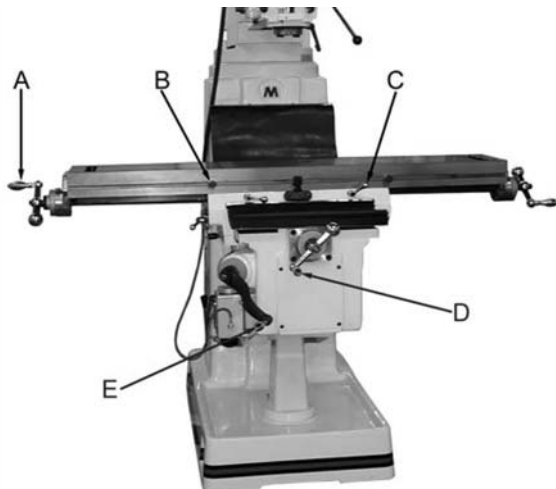

Figure 12: Table movement

12.10 Feed trip adjustment

Refer to Figure 13.

1. Loosen lock nut (A, Figure 13).
2. Engage trip handle (C) by pulling away from head assembly.
3. Adjust micro nuts (E) against quill stop (B).
4. Slowly turn adjusting screw (D) until lever (C) trips.
5. Tighten lock nut (A).

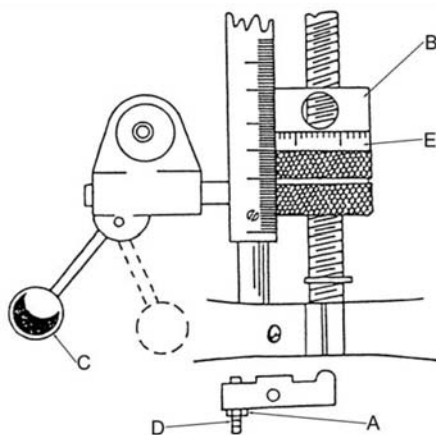

Figure 13: Feed trip adjustment

12.11 Variable frequency drive

Refer to your Delta inverter manual for any questions concerning this unit. If you suspect any problems with the inverter, contact JET technical services.

NOTE: This drive is not dual voltage.

13.0 Maintenance

WARNING Always disconnect machine from power source before doing any maintenance. If you do not have the knowledge or training to complete the maintenance, have an authorized JET service center maintain your mill. Failure to comply may cause serious bodily injury.

13.1 General maintenance

- During operation, occasionally vacuum and brush chips and debris from machine.
- Periodically operate knee and table lead screws through full range of movement to evenly distribute lubricant (particularly when applied using the “one-shot” system).
- Periodically apply light machine oil to work table and other exposed metal surfaces to prevent rust or corrosion.
- Periodically remove vent panels to check pulleys and belts for unusual wear or grooving. Operators should vary speed occasionally to prevent formation of grooves on the pulley surfaces.
- When using a coolant pump, periodically clean the sump in the machine base to extend pump life and promote efficient cutting. Change coolant regularly at intervals recommended by the coolant supplier.

13.2 Lubrication

CAUTION Do not operate mill before lubricating the machine fully. Failure to comply may cause damage to machine.

Refer to figures 14 and 15 for areas of the mill to lubricate:

- Spindle Bearings (A, Figure 14) – fill oil cup once daily with Mobil DTE® Oil Light or equivalent.
- Zerk fitting for back gear (B, Figure 14) – Insert Mobilith AW1, or equivalent, weekly when operating in back gear mode.
- Oil Pump (C, Figure 15) – fill reservoir as needed by removing cap on top of tank and filling with Mobil Vactra® #2 oil or equivalent. Pump oil with release handle once for every hour of operation. Way surfaces and leadscrews are lubricated in this manner.
- Knee leadscrew (D, Figure 15) – lubricate with Mobilith AW2, or equivalent, once weekly.

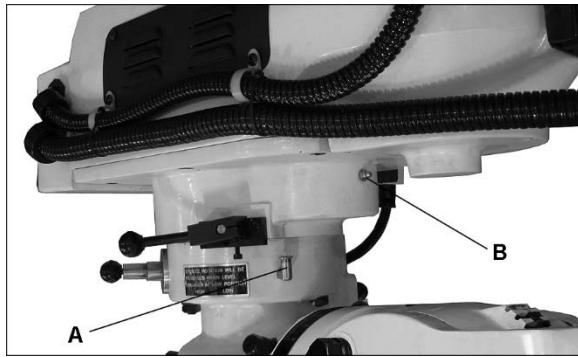

Figure 14: Lubrication points



Figure 15: Lubrication points

13.3 Gib adjustment

Refer to Figure 16.

The table, saddle, knee and ram are equipped with adjustable gibs. The gibs may require adjustment if unusual vibration is noted when locking mechanisms are off, or if you experience unusual vibration when spindle speed, tooth pitch or depth of cut do not account for the vibration.

NOTE: When adjusting table, saddle and knee gibs, always start with knee first; adjust saddle second, and adjust table last.

13.3.1 Knee gibs

Adjust two gibs located between knee and column, under the wiper (A, Figure 16). Use a dial indicator to measure the amount of movement in knee. Adjust gib until indicator reading is within 0.003".

13.3.2 Saddle gibs

Adjust three gibs (B,C) located between saddle and knee. Use dial indicator to measure amount of movement in saddle. Adjust gib until indicator reading is within 0.003".

13.3.3 Table gib

Adjust one gib (D) located between table and saddle. Use dial indicator to measure amount of movement in table. Adjust gib until indicator reading is within 0.003".

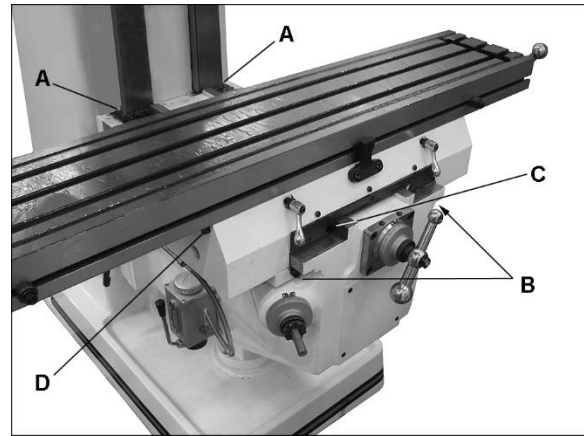

Figure 16: Gib locations

13.3.4 Ram gib adjustment

Adjust one gib (E, Figure 17) using the two set screws (F). Tighten the nuts on the set screws after adjusting.

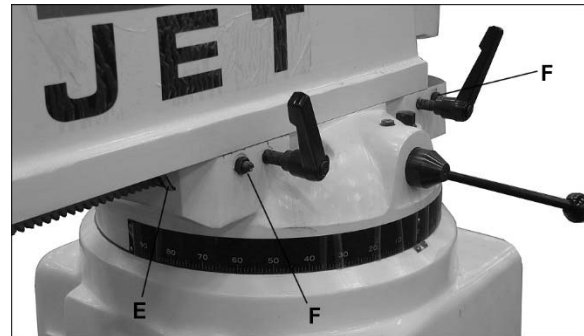

Figure 17: Ram gib location

13.4 Leadscrew backlash adjustment

The milling machine table is moved by a leadscrew and nut for each machine axis. For proper operation, there must be clearance between leadscrew and nut, which results in backlash. A second feed screw nut is provided to eliminate most of the backlash. The following procedures provide instructions for obtaining acceptable backlash.

13.4.1 Cross feed backlash

Refer to Figure 18.

1. Use cross feed crank to move table to extreme rear of its travel (toward column).
2. Remove pleated way cover.
3. Open the two chip guards (#61/62, sect. 14.3.1) enough to expose cross feed adjustment nut (the nut toward rear of feed nut bracket is not adjustable; only front nut is adjustable).
4. Loosen the two nut locking screws.
5. Turn nut slightly to tighten it against opposing nut.

6. Tighten the two nut locking screws.
7. Using cross-feed crank, move table to middle position.
8. Set up a dial indicator to check cross feed backlash. Gently move cross feed crank back and forth while watching dial indicator. Backlash should be between 0.003 inch and 0.005 inch.
9. If necessary, repeat the above steps to set backlash.
10. Install pleated way cover.

13.4.2 Longitudinal backlash

Refer to Figure 18.

1. Only one of the longitudinal leadscrew nuts can be adjusted; the other nut is fixed. The left

hand nut is typically adjustable. This can be determined by looking at nut from underside of table.

2. Loosen the two nut locking screws.
3. Turn the nut slightly to tighten it against the opposing nut.
4. Tighten the two nut locking screws.
5. Using one of the longitudinal table cranks, move table to middle position.
6. Set up a dial indicator to check longitudinal backlash. Gently move crank back and forth while watching dial indicator. The backlash should be between 0.003 inch and 0.005 inch.
7. If necessary, repeat the above steps to set backlash.

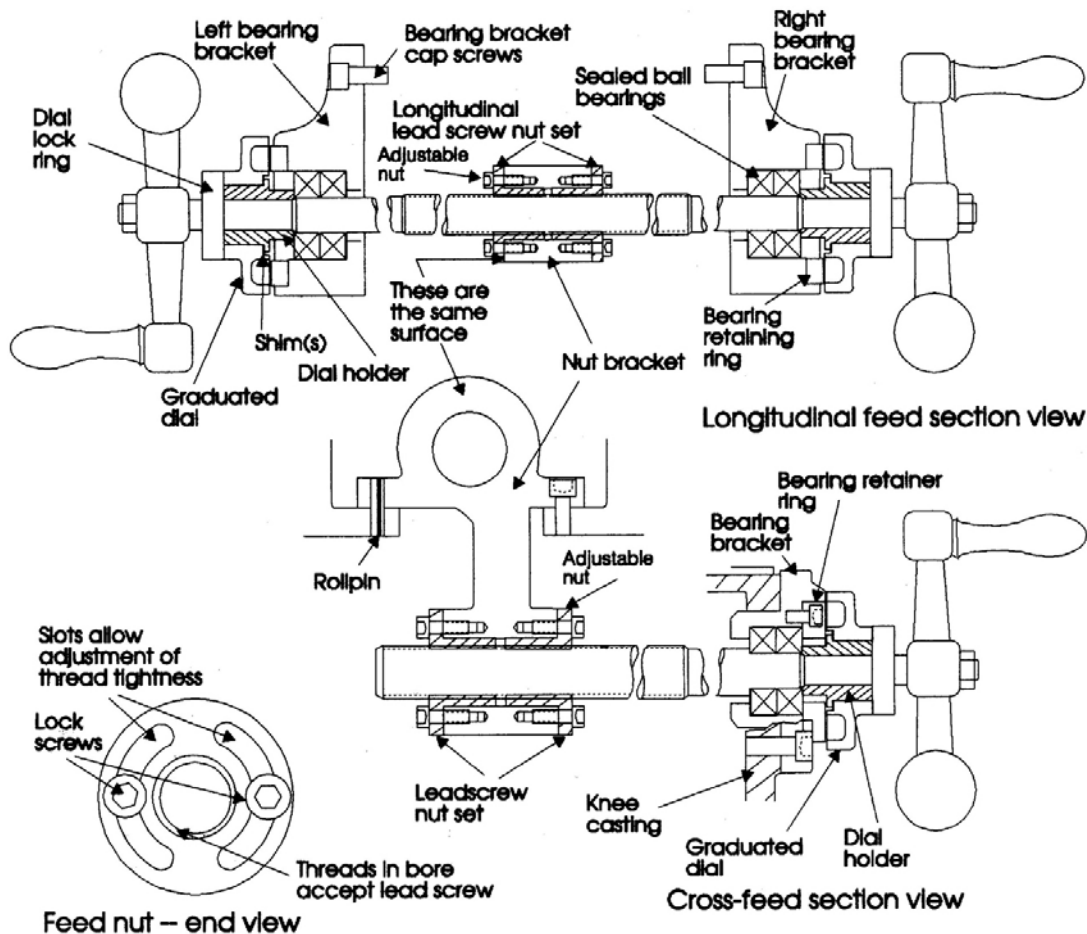

Table Lead Screw Components

Figure 18: Leadscrew backlash adjustment

14.0 Replacement parts

Replacement parts are listed on the following pages. To order parts or reach our service department, call 1-800-274-6848 Monday through Friday, 8:00 a.m. to 5:00 p.m. CST. Having the Model Number and Serial Number of your machine available when you call will allow us to serve you quickly and accurately.

14.1.1 JTM-1050EVS Inverter Speed Head Assembly – Exploded View

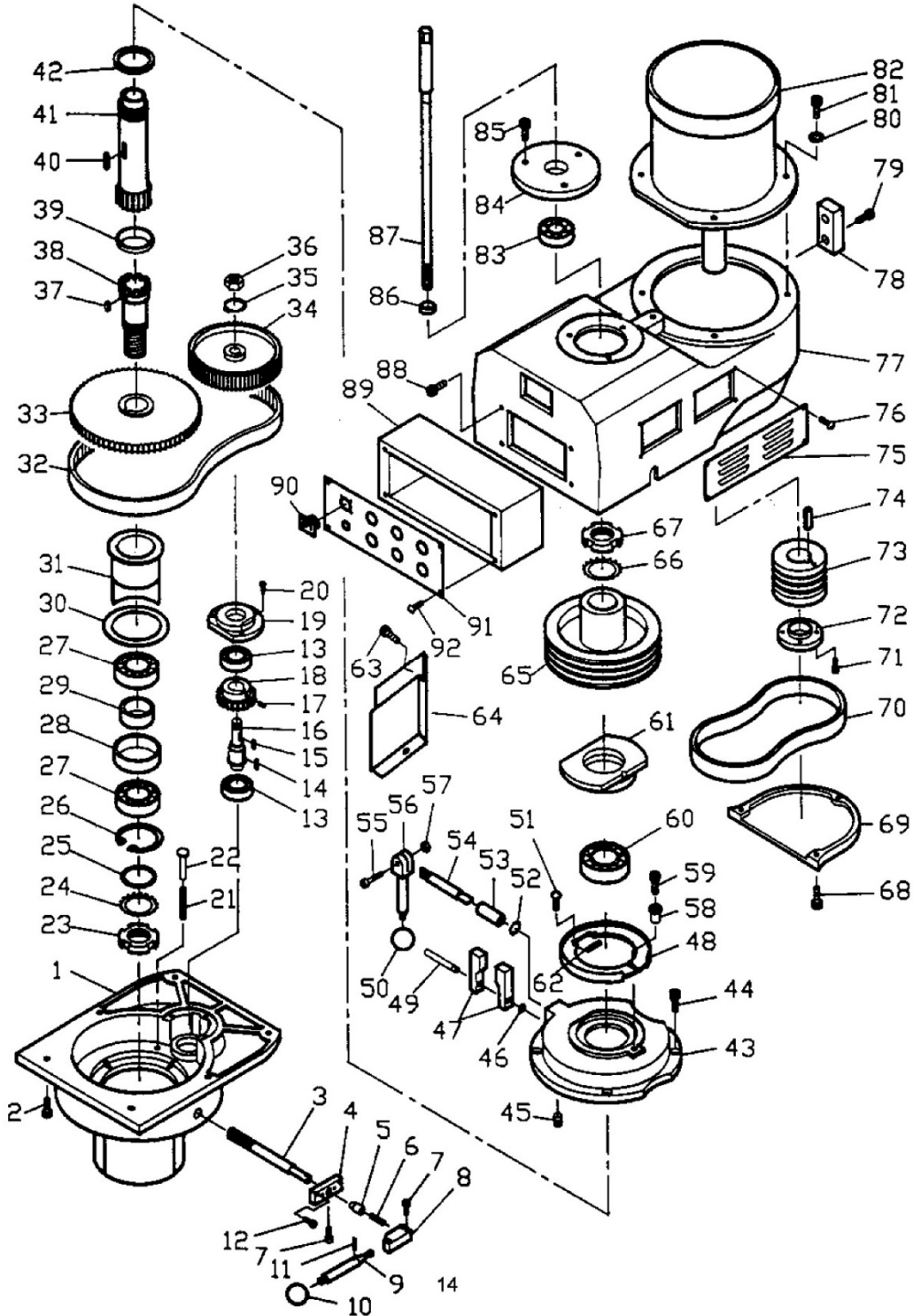

14.1.2 JTM-1050EVS Inverter Speed Head Assembly – Parts List

Index No	Part No	Description	Size	Qty
1	PVS-082	Housing		1
2	TS-1503051	Hex Socket Cap Screw	M6*20	6
3	PVS-087	Gear Shaft Pinion		1
4	PVS-089	Detent Plate		1
5	PVS-090	Bearing Stop		1
6	PVS-091	Spring		1
7	TS-1503011	Hex Socket Cap Screw	M5*14	3
8	PVS-092	Pinion Block		1
9	PVS-094	Pinion Crank		1
10	PVS-099	Plastic Ball		1
11	IVS-011	Spring Pin	3*20	1
12	TS-1502041	Hex Socket Cap Screw	M5*16	3
13	BB-6203ZZ	Ball Bearing	6203ZZ	2
14	KEY5518	Key	5*5*18	1
15	KEY5515	Key	5*5*15	1
16	PVS-067	Counter Shaft		1
17	TS-1523011	Set Screw	M6*6	1
18	PVS-066	Bull Gear		1
19	PVS-064	Bearing Housing		1
20	TS-1502051	Hex Socket Cap Screw	M5*20	3
21	PVS-084	Spring		3
22	PVS-102	Spring Shaft		3
23	PVS-081	Nut		1
24	PVS-109	Lock Washer		1
25	PVS-103	Washer		1
26	PVS-080	Snap Ring	C-62	1
27	BB-6908ZZ	Ball Bearing	6908ZZ	2
28	PVS-079	Bearing Washer		1
29	PVS-078	Bearing Washer		1
30	PVS-076	Washer		1
31	PVS-075	Rack Cup		1
32	PVS-063	Timing Belt	225L100	1
33	PVS-074	Gear		1
34	PVS-062	Timing Belt Pulley		1
35	IVS-035	Spring Washer	5/8"	1
36	PVS-061	Nut	5/8"-18NF	1
37	KEY8712	Key	8*7*12	1
38	PVS-073	Spindle Gear Hub		1
39	PVS-100	Collar		1
40	KEY7740	Key	7*7*40	1
41	4VS-H003	Spindle Pulley Hub		1
42	IVS-042	Collar		2
43	PVS-050	Lower Housing Cover		1
44	TS-1503051	Hex Socket Cap Screw	M6*20	4
45	TS-1523011	Set Screw	M6*6	1
46	IVS-046	Snap Ring	S-8	1
47	PVS-059	Brake Stud		2
48	PVS-047	Brake Lining		1
49	PVS-058	Brake Finger Pivot Stud		1
50	PVS-099	Plastic Ball		2
51	IVS-051	Round Head Screw		4
52	IVS-052	Snap Ring	S-12	1
53	PVS-052	Brake Shaft Sleeve		1
54	PVS-053	Brake Lock Shaft		1
55	TS-1503061	Hex Socket Cap Screw	M6*25	1
56	PVS-054	Brake Lock Block		1
57	TS-1540041	Nut	M6	1
58	PVS-048	Lock Screw		1
59	TS-1502041	Hex Socket Cap Screw	M5*16	1
60	BB-6010ZZ	Ball Bearing	6010ZZ	1

Index No	Part No	Description	Size	Qty
61	PVS-046	Bearing Cover		1
62	PVS-049	Brake Spring		2
63	TS-1502051	Hex Socket Cap Screw	M5*20	4
64	4VS-001	Brake Ring		1
65	4VS-002	Pulley		1
66	IVS-066	Washer		1
67	IVS-067	Lock Nut		1
68	TS-1502051	Hex Socket Cap Screw	M5*20	3
69	PVS-011	Motor Pulley Cover		1
70	IVS-070	Belt		1
71	TS-1502041	Hex Socket Cap Screw	M5*16	6
72	1020-H071	Lock Ring		1
73	1020-H070	Motor Pulley		1
74	KEY10830	Key	10*8*30	1
75	PVS-101	Cover		2
76	IVS-076	Round Head Screw		8
77	PVS-001	Housing		1
	1050FA	Fan Assembly (not shown)		1
78	SP-060	Block		1
79	TS-1504051	Hex Socket Cap Screw	M8*25	3
80	IVS-080	Spring Washer	M10	4
81	IVS-081	Hex Socket Cap Screw	M10*30	4
82	IVS-082	Inverter Motor	3HP/4P	1
	MR516D	Motor Fan (not shown)		1
83	BB-6007ZZ	Ball Bearing	6007ZZ	1
84	PVS-013	Cover		1
85	TS-1502041	Hex Socket Cap Screw	M5*16	3
86	PVS-115	Draw Bar Washer		1
87	PVS-114	Draw Bar		1
88	TS-1503021	Hex Socket Cap Screw	M6*10	4
89	4VSE187	Operation Box		1
90	IVS-090	R.P.M Indicator		1
91	4VSE186	Operation Panel		1
92	IVS-092	Round Head Screw		6
	1050EVS-RMC1100	Short Cable (Switch-Junction) (not-shown)		1
	1050EVS-REC4000	Long Cable (Switch-Electrical Box) (not shown)		1

14.2.1 JTM-1050EVS Head Assembly – Exploded View

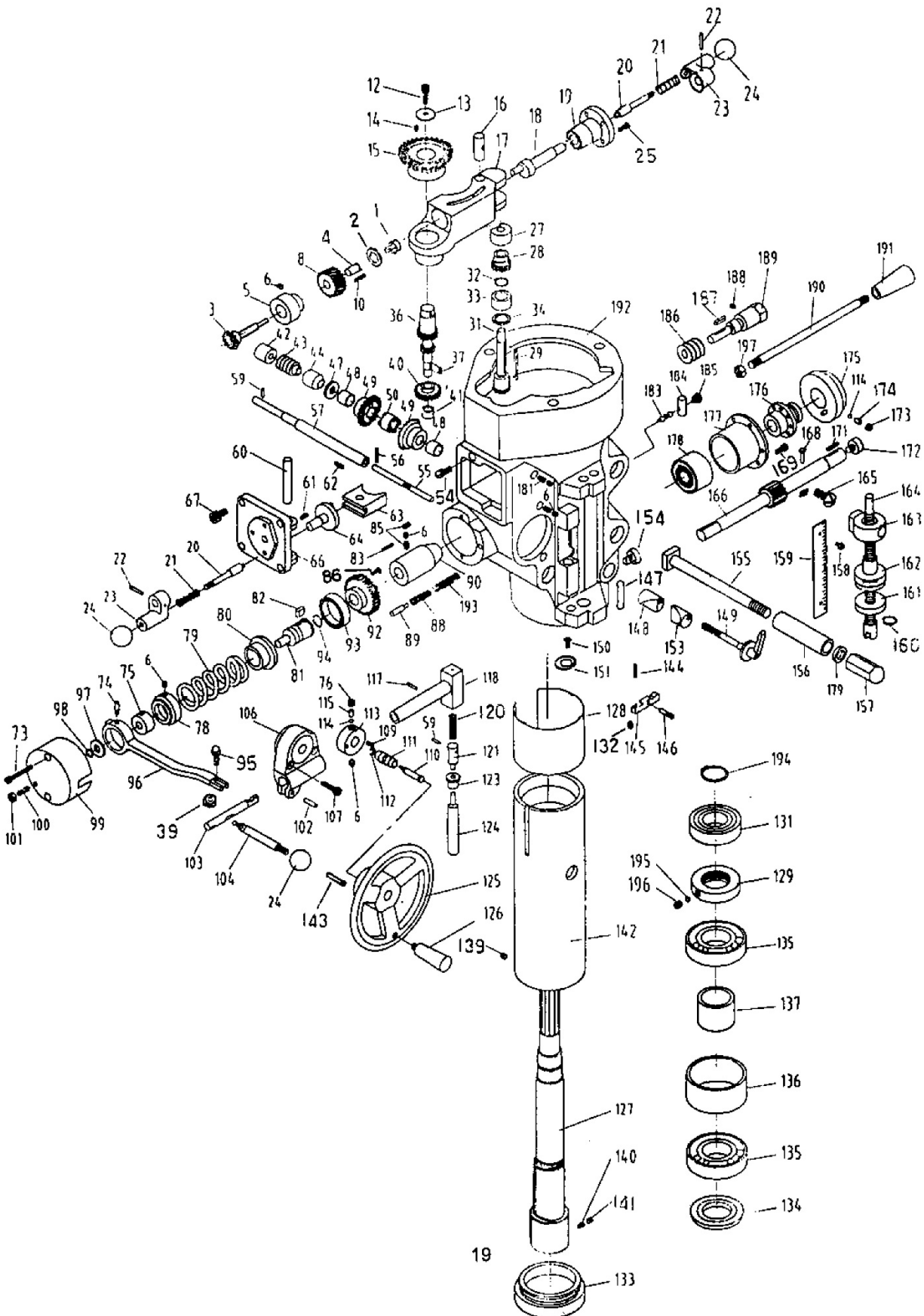

14.2.2 JTM-1050EVS Head Assembly – Parts List

Index No	Part No	Description	Size	Qty
1	TS-1503031	Hex Socket Cap Screw	M6*12	1
2	1050B-2	Washer		1
3	1050B-3	Feed Bevel Pinion		1
4	1050B-4	Worm Gear Shaft Sleeve		1
5	1050B-5	Bushing		1
6	TS-1522011	Set Screw		1
8	1050B-8	Worm Gear		1
10	KEY3312	Key	3*3*12	1
12	TS-1504031	Hex Socket Cap Screw	M8*16	1
13	B-13	Washer		1
14	KEY3308	Key	3*3*8	2
15	B-15	Bevel Gear		1
16	B-16	Feed Engage Pin		1
17	1050B-17	Worm Gear Cradle		1
18	B-18	Worm Gear Cradle Shaft		1
19	1050B-19	Shaft Sleeve		1
20	B-20	Gear Shaft Plunger		2
21	B-21	Spring		2
22	1050B-22	Spring Pin	3*20	2
23	B-23	Shift Crank		2
24	B-24	Black Plastic Ball		3
25	TS-1503010	Hex Socket Cap Screw	M5x12	3
27	B-27	Bushing		1
28	B-28	Gear		1
29	KEY3345	Key	3*3*45	1
31	1050B-31	Gear Shaft		1
32	1050B-32	Snap Ring	S-16	1
33	1050B-33	Bevel Gear Bushing		1
34	1050B-34	Spacer		1
36	1050B-36	Gear		1
39	TS-1540031	Nut	M5	1
40	1050B-40	Feed Drive Gear		1
41	1050B-41	Needle Bearing		1
42	1050B-42	Bushing		1
43	1050B-43	Worm Gear		1
44	B-44	Bushing		1
47	B-47	Washer		1
48	B-48	Bushing		2
49	B-49	Bevel Gear		2
50	B-50	Feed Reverse Clutch		1
54	TS-1503061	Hex Socket Cap Screw	M6*25	1
55	B-55	Reverse Clutch Rod		1
56	B-56	Spring Pin	3*20	1
57	B-57	Feed Worm Shaft		1
58	TS-1523011	Set Screw	M6*6	1
59	B-59	Spring Pin	3*12	2
60	B-60	Chip Guards		1
61	TS-1522031	Set Screw	M5*10	1
62	KEY3315	Key	3*3*15	2
63	B-63	Feed Gear Shift Fork		1
64	B-64	Gear Shift Crank		1
66	B-66	Cluster Gear Cover		1
67	TS-1502031	Hex Socket Cap Screw	M5*12	4
73	TS-1502081	Hex Socket Cap Screw	M5*35	2
74	B-74	Clutch Ring Pin		2
75	B-75	Clutch Ring		1
76	TS-1523021	Set Screw	M6*8	1
78	B-78	Clutch Locknut		1
79	B-79	Safety Clutch Locknut		1
80	B-80	Overload Clutch		1

Index No	Part No	Description	Size	Qty
81	B-81	Overload Clutch Sleeve		1
82	KEY5813	Key	5*8*13	1
83	B-83	Hex Socket Head Bolt		3
85	TS-1523011	Set Screw	M6*6	2
86	B-86	Cross Plate Screw	M4*16	4
88	B-88	Spring		1
89	B-89	Spring Plunger		1
90	B-90	Bushing		1
92	B-92	Worm Gear		1
93	B-93	Clutch Ring		1
94	B-94	Snap Ring	S-10	1
95	TS-1502051	Hex Socket Cap Screw	M5*20	1
96	B-96	Clutch Trip Lever		1
97	B-97	Clutch Washer		1
98	B-98	Snap Ring	S-10	1
99	B-99	Clutch Arm Cover		1
100	C-19-1	Set Screw	M6*16	1
101	TS-1540041	Nut	M6	1
102	B-102	Spring Pin	5*18	1
103	B-103	Cam Rod		1
104	B-104	Trip Handle		1
106	B-106	Feed Trip Bracket		1
107	TS-1503051	Hex Socket Cap Screw	M6*20	1
108	TS-1523031	Set Screw	M6*10	1
109	KEY3310	Key	3*3*10	1
110	B-110	Knob Stud		1
111	B-111	Reverse Knob		1
112	B-112	E-Ring	E-6	1
113	B-113	Handle Wheel Clutch		1
114	B-114	Steel Ball	3/16"	2
115	B-115	Compression Spring		2
116	B-116	Set Screw	M8*6	1
117	B-117	Spring Pin	3*15	1
118	B-118	Cam Rod Sleeve		1
119	B-119	Spring Pin	3*12	1
120	B-120	Compression Spring		1
121	B-121	Trip Plunger		1
123	B-123	Bushing		4
124	B-124	Feed Trip Plunger		1
125	B-125	Handle Wheel		1
126	B-126	Handle		1
127	B-127	Spindle		1
128	B-128	Quill Skirt		1
129	B-129	Locknut		1
131	BB-6206ZZ	Ball Bearing	6206ZZ	1
132	B-132	Nut	M4	1
133	B-133	Nose Piece		1
134	B-134	Spindle Dirt Shield		1
135	BB-7207C	Angular Bearing	7207	1
136	B-136	Spacer		1
137	B-137	Spacer		1
138	BB-7207C	Angular Bearing	7207	1
139	B-139	Set Screw		1
140	B-140	Set Screw		1
141	TS-1523011	Set Screw	M6*6	1
142	B-142	Quill		1
143	B-143	Spring Pin	3*16	1
144	B-144	Set Screw	M4*20	1
145	B-145	Feed Trip Lever		1
146	B-146	Trip Lever Pin		1
147	B-147	Indicator Rod		1
148	B-148	Quill Lock Sleeve		1

Index No	Part No	Description	Size	Qty
149	B-149	Lock Handle		1
150	B-150	Round Head Screw	M5*8	2
151	B-151	Washer	M5	2
153	B-153	Quill Lock Sleeve		1
154	B-154	Indicator Rod Screw		1
155	B-155	T-Bolt		4
156	B-156	Spacer		4
157	B-157	Adapter Nut		4
158	B-158	Round Head Screw		2
159	B-159	Micrometer Scale		1
160	B-160	Snap Ring	S-16	1
161	B-161	Quill Micro-Stop Nut		1
162	B-162	Quill Micro-Stop Nut		1
163	B-163	Quill Stop Knob		1
164	B-164	Quill Micro-Stop Nut		1
165	B-165	Round Head Screw	M10*15	1
166	B-166	Quill Pinion Shaft		1
168	B-168	Pin		1
169	TS-1503010	Hex Socket Cap Screw	M5*12	2
171	KEY3320	Key	3*3*20	1
172	B-172	Pinion Shaft Hub Screw		1
173	B-173	Set Screw	5/16"*1/4"	1
174	B-174	Compression Spring		1
175	B-175	Handle Hub		1
176	B-176	Hub Sleeve		1
177	B-177	Cover with #178 Spring		1
178	B-178	Clock Spring		1
179	B-179	Washer		4
181	TS-1523041	Set Screw	M6*12	2
183	B-183	Reverse Trip Ball Lever		1
184	B-184	Reverse Trip Plunger		1
185	B-185	Trip Ball Lever Screw		1
186	B-186	Worm Gear		1
187	KEY4418	Key	4*4*18	1
188	B-188	Set Screw		1
189	B-189	Worm Shaft		1
190	B-190	Pinion Shaft Hub Handle		1
191	B-191	Black Plastic Ball		1
192	B-192	Quill Housing		1
193	B-193	Compression Spring		1
194	B-194	Snap Ring	S-30	1
195	B-195	Bush		1
196	TS-1523011	Set Screw	M6*6	1
197	B-197	Nut		1

14.3.2 JTM-1050EVS Base Assembly – Parts List

Index No	Part No	Description	Size	Qty
1	1050C-1	Worm Washer		1
2	1050C-2	Ram Adaptor		1
3	1050C-3	Adaptor Scale		1
4	1050C-4	Lock Nut		1
6	1050C-6	Worm Gear		1
7	1050C-12	Collar		1
8	1050C-8	Worm Shaft		1
9	OVS10-033	Key	5x5x50	1
10	1050C-10	Ram		1
11	1050C-11	Hook	3/4"	1
12	C-7-1	Washer		1
13	TS-1504061	Hex Socket Cap Screw	M8x30	2
14	1050C-14	Spring Pin		1
15	1050C-15	Angle Plate		1
16	1050C-16	Rivet		12
17	1050C-17	Adaptor Pivot Stud		1
18	C-18	Washer		3
19	C-19	Locking Bolt		3
23	C-23	Table		1
31	C-31	T-Bolt		2
32	C-32	Table Stop Piece		2
33	C-33	Hex Nut	3/8"-16NC	2
34	C-34	Chip Guard		1
36	C-36	Pan Head Screw	3/16"x3/8"	4
38	C-38A	Saddle Lock Bolt		5
39	C-29	Saddle Lock Plunger		1
40	C-40	Hex Socket Cap Screw		2
41	C-41	Adjusting Screw		10
42	C-42	Table Stop Bracket		1
43	C-43	Gib		1
46	C-46	Table Lock Plunger		4
48	C-48	Turret Scale, JTM-1050		1
49	C-49	Saddle Knee Gib		1
50	C-50-1	Wiper		2
51	C-51	Pan Head Screw		18
52	C-52	Saddle		1
54	C-54	Knee Wiper Felt		1
55	C-55	Knee Column Gib		1
58	C-58	Knee Wiper Felt		1
60	C-60	Chip Guard		1
61	C-61	Chip Guard		1
62	C-62	Chip Guard		1
63	C-63	Chip Guard		1
64	C-64	Knee		1
71	C-71	Pan Head Screw		8
72	C-72	Cover		1
73	C-23-1	Washer		1
74	C-74	Nut	1/2"-20NF	1
75	KEY5525	Key	5x5x25	1
76	C-76	Washer		1
77	C-77	Bevel Gear		1
78	C-78	Front Cover		1
79	BB-5305ZZ	Ball Bearing	5305	1
80	C-80	Bearing Stop		1
81	TS-1503051	Hex Socket Cap Screw	M6x20	3
82	C-82	Leadscrew		1
83	C-83	Handle		1
84	C-84	Elevating Crank		1
85	C-85	Gear Shear Clutch		1
86	C-86	Dial Lock Nut		1

Index No	Part No	Description	Size	Qty
87	C-87	Dial		1
88	C-88	Dial Holder		1
89	TS-1503051	Hex Socket Cap Screw	M6x20	3
90	C-90	Bearing Stop		1
91	BB-6204ZZ	Ball Bearing	6204ZZ	2
92	C-92	Bearing Stop		1
93	KEY3318	Key	3x3x18	1
94	C-94	Shaft		1
95	C-95	Grub Set Screw		1
96	C-96	Bevel Gear		1
97	KEY4418	Key	4x4x18	1
98	C-98	Column		1
100	C-19-1	Collar		1
102	TS-1505051	Hex Socket Cap Screw	M10x35	2
103	C-103	Lead Screw Housing		1
104	C-82-1	Lead Screw Nut		1
105	TS-1503051	Hex Socket Cap Screw	M6x20	3
108	C-38A	Lock Bolt		2
109	C-109	Nut	3/8"	2
110	C-110	Set Screw		2
111	C-111	Gib		1
112	C-112	Gib Holder (L)		1
113	C-113	Gib		1
114	C-114	Gib Holder (R)		1
115	TS-1505051	Hex Socket Cap Screw	M10x35	8
118	C-118	Spider		1
120	C-120	Ram Pinion		1
123	C-123	Spring Washer		4
124	C-124	Turret		1
126	C-126	Ram Lock Plunger		2
127	C-127	Locking Bolt		4
128	C-128	Ram Pinion Set Screw		1
129	C-129	Rivet		2
130	C-130	Strainer		1
131	STRIPE-1-3/4	JET Stripe (not shown)	1-3/4"W	per ft.
132	C-132	Chip Pan		1
	1050EVSTBC	Toolbox Complete (not shown)		1
	1050EVSBOX	Inverter Side Box with Door (not shown)		1
	1050EVSLOCK	Door Lock with Key (not shown)		2
	1050EFA	Electric Box Fan (not shown)		1

14.4.1 JTM-1050EVS Table Leadscrew Assembly – Exploded View

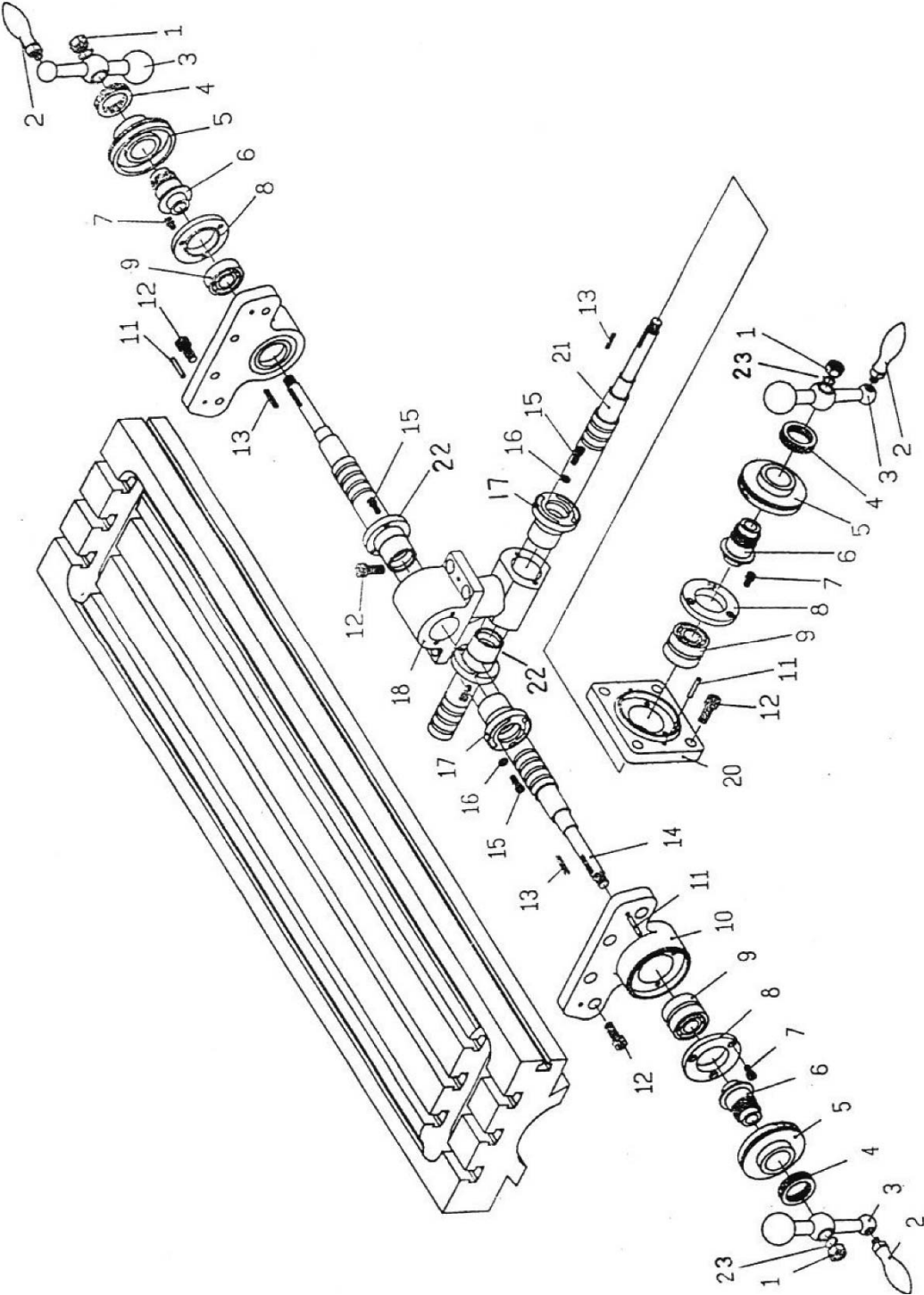

14.4.2 JTM-1050EVS Table Leadscrew Assembly – Parts List

Index No	Part No	Description	Size	Qty
1	D-1	Nut	1/2"-20NF	3
2	D-2	Handle		3
3	D-3	Ball Crank		3
4	D-4	Dial Lock Nut		3
5	D-5	Dial		3
6	D-6	Dial Holder		3
7	TS-1503031	Hex Socket Cap Screw	M6x12	9
8	C-90	Bearing Stop		3
9	BB-6204ZZ	Ball Bearing	6024ZZ	5
10	D-10	Bearing Bracket		2
11	D-11	Spring Pin	5x25	6
12	TS-1505031	Hex Socket Cap Screw		16
13	KEY3325	Key	3x3x25	3
14	D-14	Leadscrew		1
15	TS-1503061	Hex Socket Cap Screw		10
16	H-9	Washer		4
17	D-17	Feed Screw Nut		2
18	D-18	Feed Nut Bracket		1
20	D-20	Cross Bearing Bracket		1
21	D-21	Cross Feed Screw		1
22	D-22	Cross Feed Nut		2
23	D-23	Spring Washer	1/2"	3

14.5.1 JTM-1050EVS One-Shot Lubrication System – Exploded View

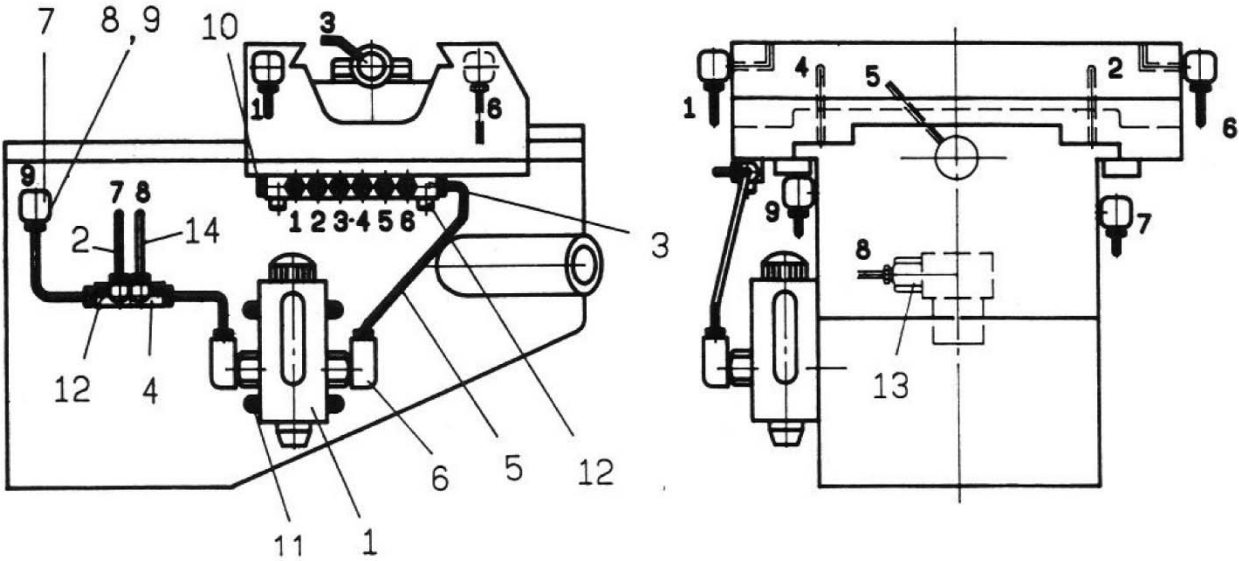

14.5.2 JTM-1050EVS One-Shot Lubrication System – Parts List

Index No	Part No	Description	Size	Qty
1	CLA-8	Handle Oiler		1
2	ALMP-04	Aluminum Pipe	13.5x450mm	1
3	A-8	Oil Regulation Distributor		1
4	A-4	Oil Regulation Distributor		1
5	A-5	Flexible Steel Tube	4x550	1
6	PH-4011	Elbow Joint		2
7	PI-401	Elbow Joint		6
8	PA-4	Thimble Nut		20
9	PB-4	Thimble		20
10	PG-004	Union		1
11	JTM4VS-BUTW1458	Screw	M6x14	4
12	TS-1502061	Hex Socket Cap Screw	M5x25	4
13	PD-401	Straight Joint		1
14	A-14	Nylon Piece	4x700	1

14.6.1 JTM-1050EVS Electrical Panel – Parts List

Index No	Part No	Description	Size	Qty
1	1050EVS-SB1	Emergency Stop		1
2	1050EVS-SB2	Spindle Stop		1
3	1050EVS-SB3	Power Feed On		1
4	1050EVS-SA1	Fwd.-0-Rev. Spindle On		1
5	1050EVS-SA2	Pump Select Switch		1
6	1050EVS-MS	Power On/Off		1
7	1050EVS-L1	Power Lamp		1
8	1050EVS-L2	Power Feed Lamp		1
9	1050EVS-TR	Transformer		1
10	1050EVS-M1	Motor Fwd. Contact Relay		1
11	1050EVS-M2	Motor Rev. Contact Relay		1
12	1050EVS-M3	Power Feed Contact Relay		1
13	1050EVS-M4	Pump Motor Contact Relay		1
14	1050EVS-M5	Inv. Motor Contact Relay		1
15	1050EVS-FU1	High Voltage Fuse		1
16	1050EVS-FU2	Low Voltage Fuse		1
17	1050EVS-FU3	Low Voltage Fuse		1
18	1050EVS-LS1	Door Limit Switch		1
19	1050EVS-LS2	Brake Limit Switch		1
20	1050EVS-VR1	Speed Adjuster Spindle		1
21	1050EVS-R1	Relay		1
22	1050EVS-R	Regenerative Brake (230V)		1
	1050EVS-RB	Regenerative Brake (460V)		1
23	1050EVS-L	Work Light (option)		1
24	1050EVS-PF	Power Feed (option)		1
25	1050EVS-INV	Spindle Control		1
	FR-A024-2.2K	230V EVS Inverter (not shown)		1
	FR-A044-2.2K	460V EVS Inverter (not shown)		1

14.6.2 JTM-1050EVS Electrical Panel Layout I

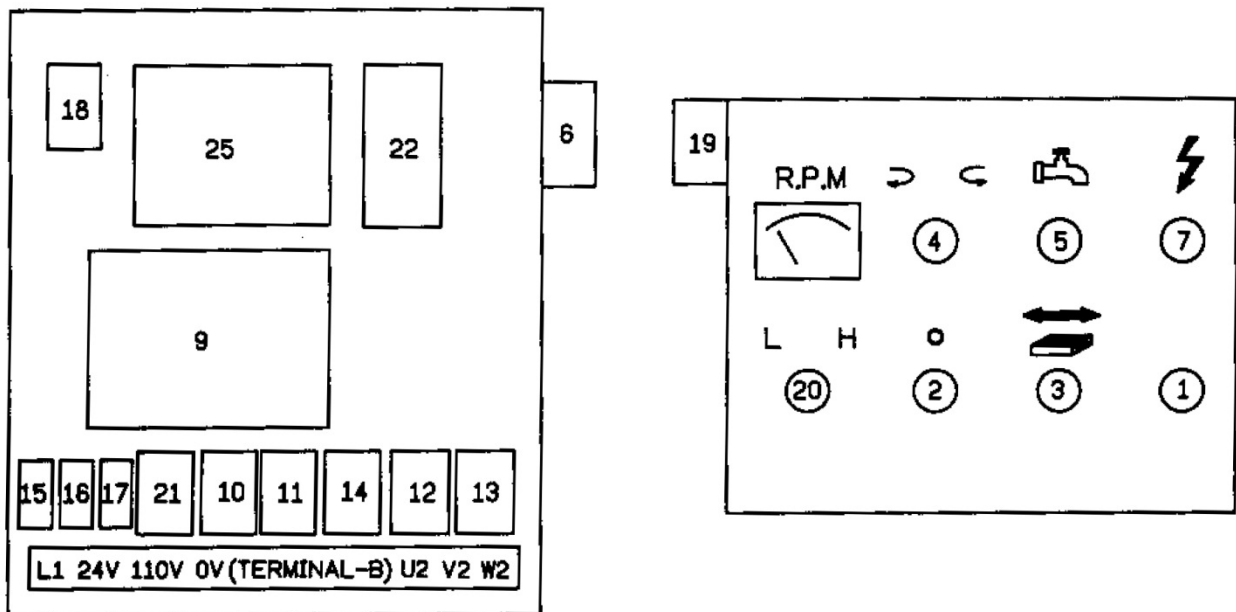

14.6.3 JTM-1050EVS Electrical Panel Layout II

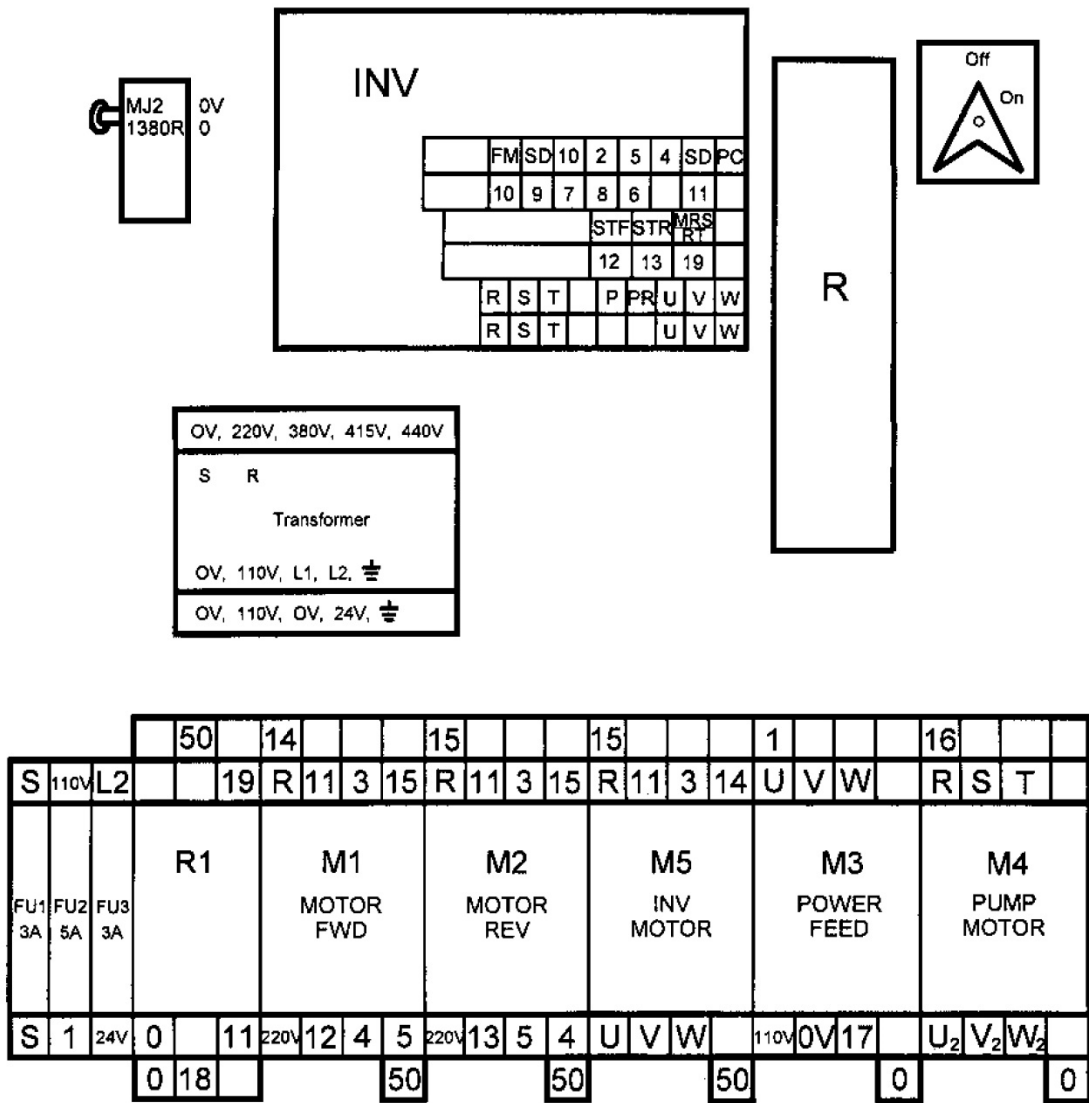

L1, 24V, 110V, 0V, 0, 1, 2, 3, 4, 5, 6, 7, 8, 9, 10, 16, 17, 18, 220V, S, U, W, ⏏ ⏏ U₂, V₂, W₂, R, S, T, ⏏

15.2 JTM-1050EVS wiring diagram

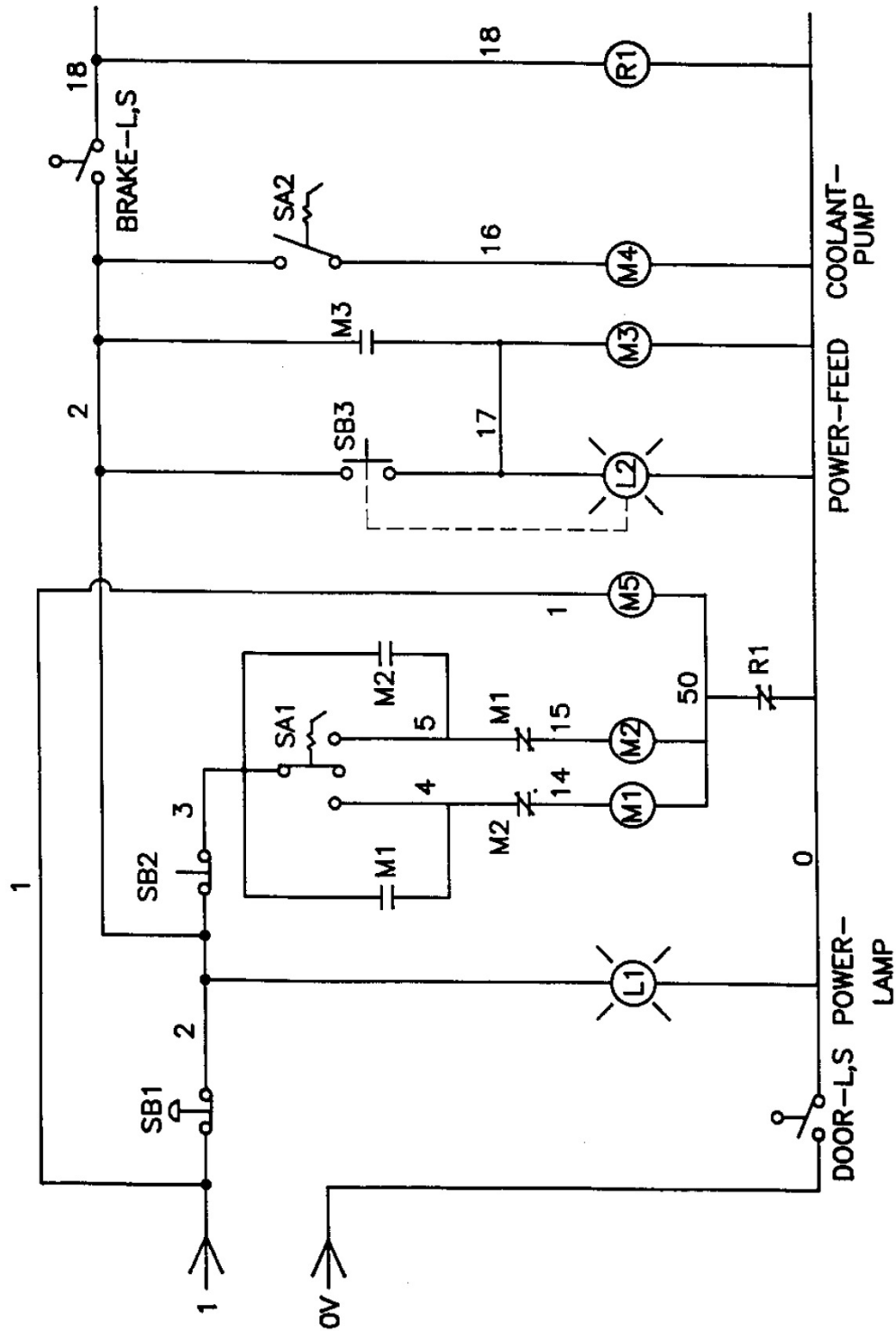

JET

427 New Sanford Road
 LaVergne, Tennessee 37086
 Phone: 800-274-6848
 www.jettools.com